



LANDIRENZO®

COMPONENTS and INSTALLATION HANDBOOK

**LANDIRENZO SYSTEM
OMEGAS - EVO**

3-4-5-6-8 CYLINDERS

MULTIPOINT

LPG

INDEX

OPERATING PRINCIPLE.....	7
INPUT SIGNALS FROM THE ENGINE.....	7
<i>Petrol injection signals.....</i>	<i>7</i>
<i>Power supply with ignition on.....</i>	<i>7</i>
<i>RPM signals.....</i>	<i>7</i>
<i>Engine coolant temperature signals.....</i>	<i>8</i>
<i>Battery voltage signals.....</i>	<i>8</i>
<i>MAP signal.....</i>	<i>8</i>
<i>Lambda probe signals (optional).....</i>	<i>8</i>
SIGNALS FROM GAS SYSTEM SENSORS.....	8
<i>Operating status signals (petrol/gas).....</i>	<i>8</i>
<i>Gas tank level signals.....</i>	<i>8</i>
<i>Gas pressure/temperature signals.....</i>	<i>8</i>
THE ECU OUT PROVIDES.....	8
DIAGRAM OF THE SYSTEM FUNCTIONING.....	9
SYSTEM MAIN COMPONENTS.....	10
<i>4 Cylinders.....</i>	<i>10</i>
<i>8 Cylinders.....</i>	<i>10</i>
LI10 - LI10 TURBO PRESSURE REGULATOR.....	11
<i>Technical data.....</i>	<i>11</i>
<i>Periodical maintenance.....</i>	<i>12</i>
LI02 PRESSURE REGULATOR.....	13
<i>Technical data.....</i>	<i>13</i>
<i>Periodical maintenance.....</i>	<i>14</i>
LI12 - LI12 TURBO REDUCER VAPORIZER.....	15
<i>Technical data.....</i>	<i>15</i>
<i>Periodical maintenance.....</i>	<i>16</i>
TEMPERATURE SENSOR (OPTIONAL).....	17
<i>Technical data.....</i>	<i>17</i>
LR025 GAS PRESSURE/TEMPERATURE/VACUUM SENSOR.....	17
<i>Technical data.....</i>	<i>17</i>
FILTERS.....	18
FL-375-2 FILTER.....	18
<i>Technical data.....</i>	<i>18</i>
FL-ONE FILTER.....	18
<i>Technical data.....</i>	<i>18</i>
FC 30 FILTER (COALESCING).....	18
<i>Technical data.....</i>	<i>18</i>

F-781 FILTER.....	18
<i>Technical data</i>	18
FL-375-2 FILTER.....	19
<i>Dimensions.....</i>	19
<i>Cross section.....</i>	19
<i>Label.....</i>	19
<i>Cartdrige replacing.....</i>	19
FL-ONE FILTER.....	20
<i>Dimensions.....</i>	20
<i>Cross section.....</i>	20
<i>Label.....</i>	20
FC 30 FILTER.....	21
<i>Dimensions.....</i>	21
<i>Label.....</i>	21
F-781 FILTER.....	22
<i>Dimensions.....</i>	22
FL01S FILTER.....	23
GAS INJECTORS GIRS12	24
<i>Technical data</i>	25
NOZZLES	26
INJECTOR NOZZLES.....	26
<i>Technical data (fig. A-B)</i>	26
<i>Technical data (fig. C).....</i>	26
COMPENSATION NOZZLE.....	26
<i>Technical data (fig. D).....</i>	26
GAS INJECTORS EVO	27
<i>Injectors with metallic case.....</i>	28
<i>Technical data.....</i>	28
<i>Injectors with plastic case.....</i>	29
GAS INJECTORS EP.....	30
<i>Technical data.....</i>	31
GAS INJECTORS GI25.....	32
<i>Technical data</i>	34
GAS INJECTORS GI-VS19	35
<i>Technical data</i>	36
LANDIRENZO OMEGAS 4.0 ECU (2-3-4 CYLINDER).....	37
<i>Technical data</i>	38
LANDIRENZO EVO OBD WIRING PIN-OUT (2-3-4 CYLINDERS).....	39
LANDIRENZO EVO OBD PIN-OUT (2-3-4 CYLINDER).....	40
LANDIRENZO OMEGAS WIRING LAYOUT (2-3-4 CYLINDER).....	41
LANDIRENZO OMEGAS EVO OBD ECU (2-3-4 CYLINDER)	42

<i>Technical data</i>	43
LANDIRENZO EVO OBD WIRING PIN-OUT (2-3-4 CYLINDER)	44
LANDIRENZO EVO OBD PIN-OUT (2-3-4 CYLINDERS)	45
LANDIRENZO EVO OBD WIRING LAYOUT (2-3-4 CYLINDERS)	46
LANDIRENZO EVO L ECU(2-3-4 CYLINDER)	47
<i>Technical data</i>	48
LANDIRENZO EVO L WIRING PIN-OUT (2-3-4 CYLINDER)	49
LANDIRENZO EVO L PIN-OUT (2-3-4 CYLINDER)	50
LANDIRENZO EVO L WIRING LAYOUT (2-3-4 CYLINDER)	51
LANDIRENZO OMEGAS 3.0 AND EVO OBD ECU (5-6-8 CYLINDERS)	52
<i>Technical data</i>	53
LR OMEGAS 3.0 AND EVO OBD PIN-OUT (5-6-8 CYLINDERS)	54
LR OMEGAS 3.0 WIRING PIN-OUT (5-6-8 CYLINDERS)	55
LANDIRENZO OMEGAS 3.0 WIRING LAYOUT (5-6-8 CYLINDERS)	56
LANDIRENZO ECU EVO OBD WIRING PIN-OUT (5-6-8 CYLINDERS)	57
LANDIRENZO ECU EVO OBD WIRING LAYOUT (5-6-8 CYLINDERS)	58
MULTIFUNCTION SWITCH	59
<i>Functions</i>	59
<i>Auto-diagnosis</i>	59
TANK	60
<i>Cylindrical tanks (fig. A)</i>	60
<i>Toroidal tanks (fig. B-C)</i>	61
HIGH PRESSURE PIPES	61
MULTIVALVES	62
<i>Refuelling valve for gasoline compartment</i>	63
<i>Bumper mounted refuelling valves</i>	63
<i>Technical data</i>	63
REFUELLING VALVE ADAPTORS	64
ECE ONU R115-00 (ON KITS THAT COMPLY WITH THAT STANDARD)	65
INSTALLATION COMPONENTS	66
<i>Before starting installation</i>	66
<i>During installation</i>	66

<i>Once the installation in complete</i>	66
<i>Periodical checks</i>	66
<i>Note</i>	67
INSTALLING THE PRESSURE REGULATOR	68
CONNECTING HEATER HOSES AND TEMPERATURE SENS. (OPTIONAL)	71
TEMPERATURE SENSOR	72
INSTALLING THE FILTER (OPTIONAL)	73
INSTALLING GAS PRESSURE /TEMPERATURE SENS. AND MAP SENS.	74
INSTALLING THE GAS INJECTORS UNIT	75
INSTALLING THE NOZZLES	78
<i>Nozzles for injectors</i>	78
<i>Nozzle for the compensation of the pressure regulator</i>	79
INSTALLING THE ECU	80
INSTALLING THE SWITCH	81
CYLINDRICAL TANK	82
INTERNAL / INTERNAL TOROIDAL TANK	84
INTERNAL / EXTERNAL TOROIDAL TANK	85
EXTERNAL / EXTERNAL TOROIDAL TANK	85
<i>Use of multivalves on cylindrical tanks</i>	86
<i>Use of multivalves on toroidal tanks</i>	86
<i>Fitting the multivalve (example on toroidal tank)</i>	86
<i>AT02 series multivalve</i>	87
INSTALLING THE MULTIVALVE GUARD ON AN EXTERNAL TANK	88
INSTALLING THE AIRTIGHT CHAMBER ON A CYLINDRICAL TANK	88
INSTALLING AIR VENTS INSIDE TRUNK COMPARTMENT	90
HIGH PRESSURE PIPES	91
INSTALLATION OF THE REFUELLING VALVE	93
<i>Refuelling valve for gasoline compartment</i>	93
<i>Version for bumper or under-bumper fitting</i>	94
PNEUMATIC DIAGRAM - WITH LI10 PRESSURE REGULATOR	95
PNEUMATIC DIAGRAM - WITH LI02 PRESSURE REGULATOR	96
PNEUMATIC DIAGRAM 6 CYLINDERS- WITH LI10 PRESSURE REGUL	97
PNEUMATIC DIAGRAM 8 CYLINDERS - WITH LI10 PRESSURE REGUL	98

OMEGAS EVO WIRING DIAGRAM.....	99
OMEGAS EVO WIRING DIAGRAM 6 CYLINDERS.....	100
OMEGAS EVO WIRING DIAGRAM 8 CYLINDERS.....	101
OMEGAS 4.0 WIRING DIAGRAM.....	102
Petrol pump cutting diagram (OPTIONAL)	103
EVO-L WIRING DIAGRAM.....	104
FUEL LEVEL SENSOR CONNECTIONS.....	105
CONNECTION VARIANTS OBD CONNECTION	105
PETROL INJECTORS EXCLUSION	106
PROGRAMMING THE ECU	107

REFERENCE STANDARDS

This manual provides details about the design and technical characteristics of the components used.

The installation instructions are based on the following guide lines:

ECE ONU R10-02 regarding electrical and electronic components for automotive applications

ECE ONU R67-01 regarding the installation of LPG components on vehicles with internal combustion engines.

ECE ONU R115-00 regarding retrofitting LPG/CNG systems on vehicles with internal combustion engines.

The CNG system described in this manual complies with ECE R83 ONU regulations regarding emissions.

IMPORTANT ADVICE

This manual also contains the following appendices:

Appendix 1: List of vehicles for which a LPG system is available that complies with R115 standards.

Appendix 2: List of alternative components



Never tamper with original Landi Renzo components especially if the engine is running or the ignition is on.



Never wash the engine or components in the engine bay with high pressure water as this could lead to water getting into components (ECU, regulator, injectors etc.) and causing damage.

LANDI RENZO S.p.A. will not accept any responsibility for harm or damage caused by unauthorised personnel tampering with its components.

OPERATING PRINCIPLE

The LANDIRENZO OMEGAS (and LANDIRENZO EVO) phased sequential system is one of the latest generation of systems available for converting from petrol to LPG in its gaseous state.

The ECU manages the system developed to allow vehicles that normally run on petrol to use alternative fuels such as LPG.

When running on gas, the original petrol ECU on the vehicle continues working while the gas ECU converts the petrol injection times into suitable command signals for the gas injectors. To avoid problems with the original petrol ECU, the new system sends “fictitious” signals to the petrol injectors that simulate everything is working properly when the injectors are deactivated.

The engine is always be started in petrol mode and, once running, if the switch is in the gas position, the gas ECU allows the engine to be run on gas once certain pre-set parameters have been reached.

Some models of ECU allow the driver to use a special procedure with the switch to start the engine in gas mode but this is for use “emergency use only”.

When the following pre-set ECU parameters:

rpm, engine coolant temperature and acceleration/deceleration conditions are reached, the solenoid valves open:

- on the tank containing the gas at a pressure that depends on composition of the gas itself and on the ambient temperature;
- on the regulator than releases the gas at a pressure of about 1 bar higher than the pressure in the intake manifolds;

After 1 minute, the system changes to gas. At this point, the petrol injectors are deactivated and the gas ECU takes over managing the gas injectors.

The gas ECU uses data from the petrol ECU to calculate the duration of gas injection impulses as well as a series of other parameters to optimise engine performance both in terms of gas consumption and emissions. The signals sent to the gas injectors are generated from a series of calculations that take the thermodynamic conditions of the gas into consideration by means of temperature and pressure sensors. Data about engine status is taken from readings of engine temperature and estimated engine load.

The gas ECU reads every petrol injection time for each cylinder and converts it into a gas injection time for each specific gas injector. The gas injector then injects exactly the right amount of gas into the combustion chamber.

INPUT SIGNALS FROM THE ENGINE

Petrol injection signals

The system uses the petrol injection times as the main parameter in calculating the amount of LPG to be injected. The gas ECU converts the petrol injection times into gas injection times and uses then actuates the gas injectors with this data.

Power supply with ignition on

The power sent to the petrol injectors in many cases is also used as a means of recognition that the ignition is on.

RPM signals

Rpm signals are one of the key parameters that, along with petrol injection times, are used to convert the former into gas injection times.

These signals are also used to check engine status (on/off). Should the engine accidentally cut out, this is detected from the lack of rpm signals and the system automatically closes the gas solenoid to stop any potential gas leaks.

Engine coolant temperature signals

The engine coolant temperature is used:

- to manage the change from petrol to gas;
- to make corrections to gas injection times.

The software uses a strategy whereby if the change from petrol to gas is not associated with the coolant temperature, it is managed by the gas temperature.

Battery voltage signals

Battery voltage signals are used to make corrections to gas injection times.

MAP signal

MAP signals from the MAP sensor on the low pressure gas line are used to handle switching back to petrol in the event of running out of LPG.

Lambda probe signals (optional)

Signals from the original lambda probe are acquired and used as feedback in the 'closed loop' system.

SIGNALS FROM GAS SYSTEM SENSORS

Operating status signals (petrol/gas)

These signals come from the switch

Gas tank level signals

These signals come from a fuel level indicator on the regulator and are sent to the switch/indicator

Gas pressure/temperature signals

These come from sensors fitted to the low pressure gas line.

THE ECU OUT PROVIDES

- gas injector command signals;
- command signals to the gas solenoids (regulator- solenoid(s) / gas tank(s);
- information about the amount of gas in the tank(s);
- saved error signals (acoustic-visual);
- lack of fuel signals (acoustic-visual);

and for several specific ECU versions:

- emulated lambda probe signals.

The ECU communicates with input/output signals with the switch (previously described functions) and with a personal computer for:

- parameter configuration;
- gas system diagnosis.

Proper calibration of the mapping obtained using Landi Renzo software ensures that no specific adaptivity to working with gas is needed. The petrol ECU can be utilised to handle any adaptivity.

The system complies with EU Directive 70/220 (appendix IX) regarding the use of fuels containing between 30 and 85% of propane.

DIAGRAM OF THE SYSTEM FUNCTIONING

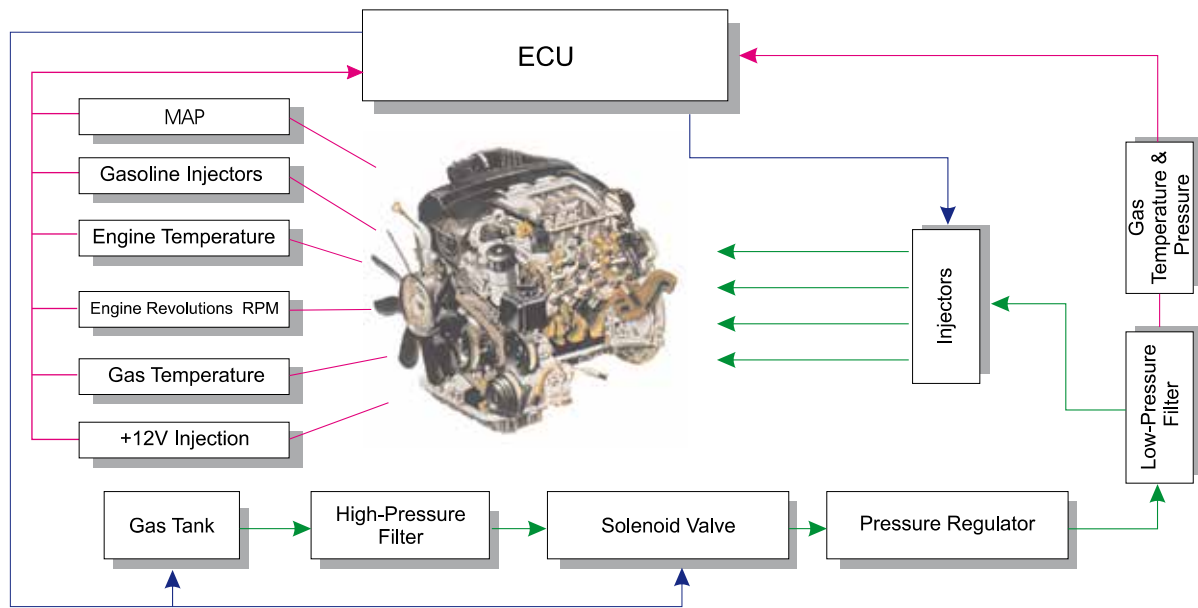

SYSTEM MAIN COMPONENTS

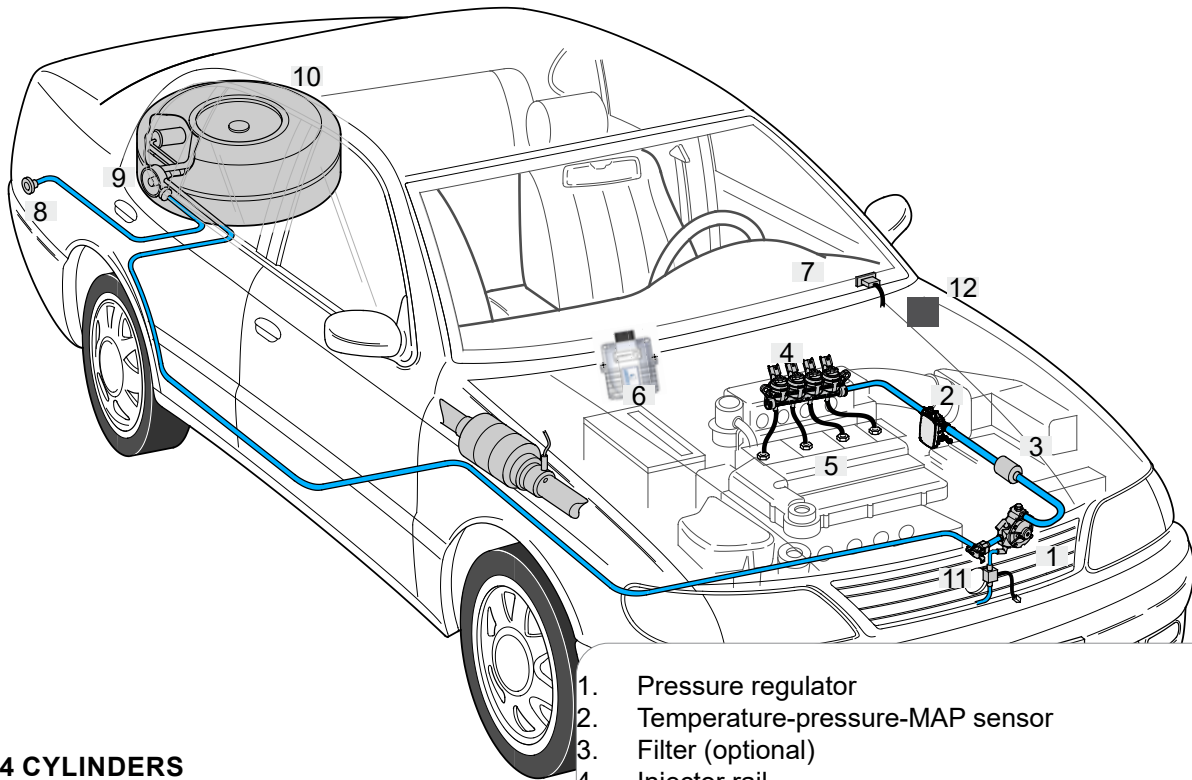

4 CYLINDERS

1. Pressure regulator
2. Temperature-pressure-MAP sensor
3. Filter (optional)
4. Injector rail
5. Nozzles
6. Fuel management ECU
7. Gas/petrol switch
8. Filler valve
9. Multivalve
10. Tank
11. Coolant temperature sensor (optional)
12. R115 Label (only for versions complying with this legislation)

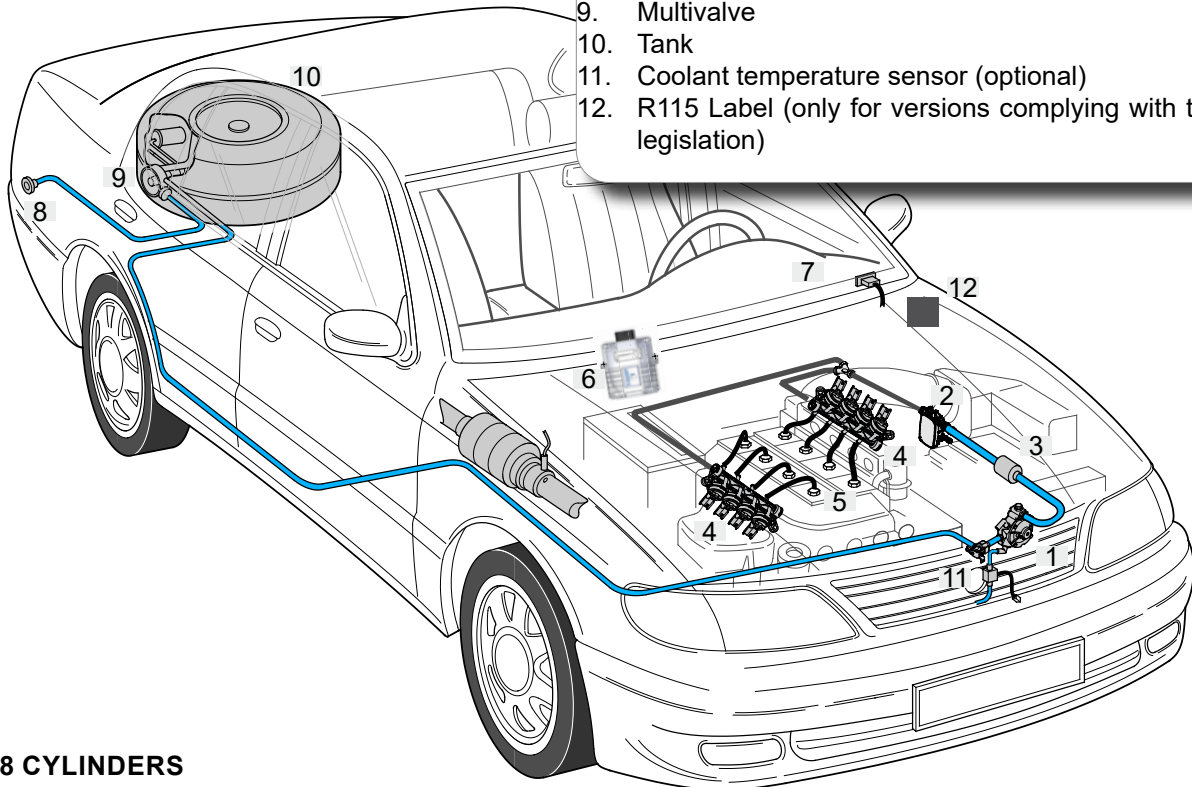

8 CYLINDERS

LI10 - LI10 TURBO PRESSURE REGULATOR

The regulator is a single stage compensated unit with a membrane with water/gas heat exchanger. The regulator is set to release gas at a pressure of 0.95 bar (95 kPa) more than the pressure in the intake manifolds of normally aspirated vehicles.

TECHNICAL DATA

Type of fuel:	LPG
Nominal operating flow rate:	35 / 40 kg/h
Operating flow rate (relative):	Asp. 0,95 bar - Turbo 1,2 bar
Safety valve pressure setting (relative):	4 bar
Operating temperature:	-20°C ÷ 120°C
Solenoid valve characteristics:	12 V - 11 W (the connector may be different, depends on the model of the solenoid valve)
Weight:	Asp. 1,4 kg - Turbo 1,5 kg
Dimension:	183x166x90 mm
Hoses connections:	
• Gas Inlet joint	Ø 6 mm - M10x1 mm / Ø 8 mm - M12x1 mm
• Gas Outlet joint	Ø 14 mm
• Heater fluid joints	Ø 16 mm (the joints may be of different diameters, depends on the reducer model)
• Vacuum / overpressure joints	Ø 5 mm
Homologation Reducer:	E13 67R-010056
Homologation Gas Electrovalve:	E3 10R-036344

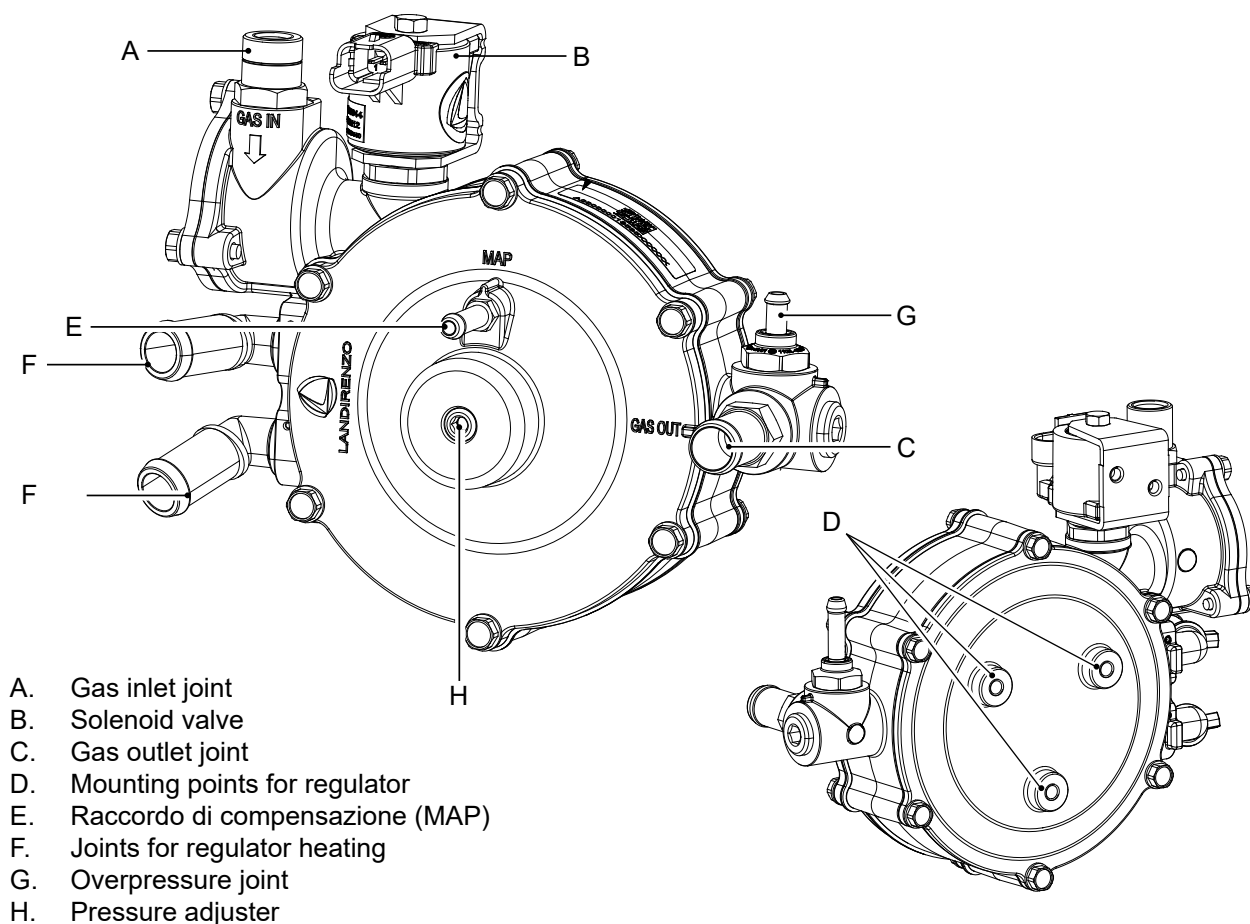

The regulator comes already tested and calibrated. No further calibration is called for on installation. With the new regulator, a slight difference in pressure can be seen in the correct operating pressure. This is due to the rigidity of the "new" membranes. The new membranes quickly bed in and after a few days, the operating pressure will be constant.

The pressure of gas at the outlet can however be adjusted if necessary.

To measure the pressure of gas at the regulator outlet, connect a PC with specific software to the fuel management ECU.

For accurate measurement of the pressure, the engine must be:

- at operating temperature;
- running at tick- over speed;
- running on gas;

Use the screw "H" to adjust the gas pressure at the outlet. Turn the screw anti-clockwise to increase the pressure and clockwise to reduce it.

ATTENTION

Do NOT turn the screw more than 6 complete turns in either direction from its original position. If you are unable to obtain the pressure setting you want with these adjustments, check the filter, gas injectors, pressure sensor etc...

Changing the gas outlet pressure values from those set by the fuel management system neither improves nor worsens engine performance and/or fuel consumption.

PERIODICAL MAINTENANCE

Gas outlet pressure check.

Complete revision based on the type of pressure regulator and as described in the Use and Maintenance Handbook.

LI02 - LI02 Turbo PRESSURE REGULATOR

The regulator is a single stage compensated unit with a membrane and a water/gas heat exchanger. The regulator is set to release gas at a pressure of 0.95 bar (95 kPa) more than the pressure in the intake manifolds of normally aspirated vehicles.

Depending on the model of regulator requested, the solenoid can be supplied separately or along with the regulator.

The solenoid comes supplied with various types of electrical connectors to adapt to specific gas system wiring requirements.

TECHNICAL DATA

Type of fuel:	LPG
Nominal operating flow rate:	23 Kg/h
Operating flow rate:	0,95 bar (95 kPa)
Safety valve pressure setting:	4 bar (400 kPa)
Operating temperature:	-20°C ÷ 120°C

Solenoid valve characteristics:	12 V - 11 W (the connector may be different, depends on the model of the solenoid valve)
---------------------------------	--

Weight:	850g
---------	------

Hoses connections:	gas outlet joint Ø 14 mm heater fluid joints Ø 15 mm vacuum / overpressure joints Ø 5 mm gas inlet joint pipe Ø 6 mm - 10x1 mm
--------------------	---

Pressure regulator homologation:	E13-67R-010056
Solenoid valve homologation:	E4-67R-0193001 - E3 10R-036344

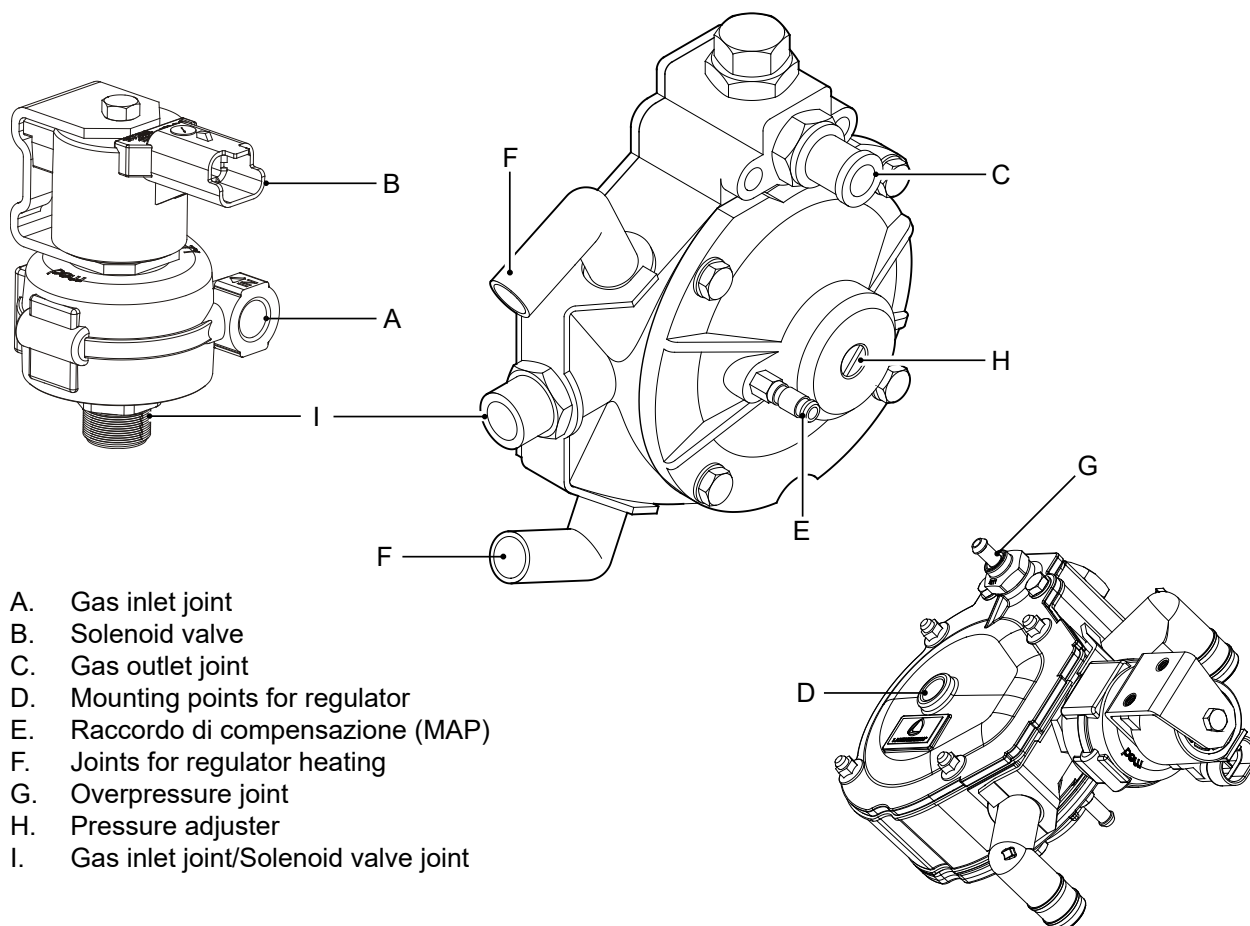

- A. Gas inlet joint
- B. Solenoid valve
- C. Gas outlet joint
- D. Mounting points for regulator
- E. Raccordo di compensazione (MAP)
- F. Joints for regulator heating
- G. Overpressure joint
- H. Pressure adjuster
- I. Gas inlet joint/Solenoid valve joint

The regulator comes already tested and calibrated. No further calibration is called for on installation. With the new regulator, a slight difference in pressure can be seen in the correct operating pressure. This is due to the rigidity of the "new" membranes. The new membranes quickly bed in and after a few days, the operating pressure will be constant.

The pressure of gas at the outlet can however be adjusted if necessary.

To measure the pressure of gas at the regulator outlet, connect a PC with specific software to the fuel management ECU.

For accurate measurement of the pressure, the engine must be:

- at operating temperature;
- running at tick- over speed;
- running on gas;

Use the screw "H" to adjust the gas pressure at the outlet. Turn the screw anti-clockwise to increase the pressure and clockwise to reduce it.

ATTENTION

Do NOT turn the screw more than 6 complete turns in either direction from its original position. If you are unable to obtain the pressure setting you want with these adjustments, check the filter, gas injectors, pressure sensor etc..

Changing the gas outlet pressure values from those set by the fuel management system neither improves nor worsens engine performance and/or fuel consumption.

PERIODICAL MAINTENANCE

Gas outlet pressure check.

Complete revision based on the type of pressure regulator and as described in the Use and Maintenance Handbook.

LI12 - LI12 TURBO REDUCER VAPORIZER

The regulator is a single stage compensated unit with a membrane with water/gas heat exchanger, equipped with a safety valve and solenoid valve and filter.

This reducer, very compact in its dimensions it adapts well to different layouts and guarantees excellent performance on the aspirated engines and turbo, with power up to 120 kW.

TECHNICAL DATA:

Weight:	1,0 kg
Dimensions:	158x144x108 mm
Nominal operating flow rate (LPG):	30 kg/h
Operating temperature:	-20÷120°C
Relative pressure of the safety valve:	4 bar (400 kPa)
Working pressure:	0,95 bar (95 kPa)
Solenoid valve characteristics:	12 V - 11 W (the connector may be different, depends on the model of the solenoid valve).
Hoses connections:	
• Gas inlet joint	Ø 6 mm - 10x1 mm
• Gas outlet joint	Ø 14 mm
• Heater fluid joints	Ø 16 mm (the joints may be of different diameters, depends on the pressure regulator model)
• Vacuum / overpressure joints	Ø 5 mm
Homologation reducer:	E13 67R-010056
Homologation solenoid valve:	E3 10R-036344

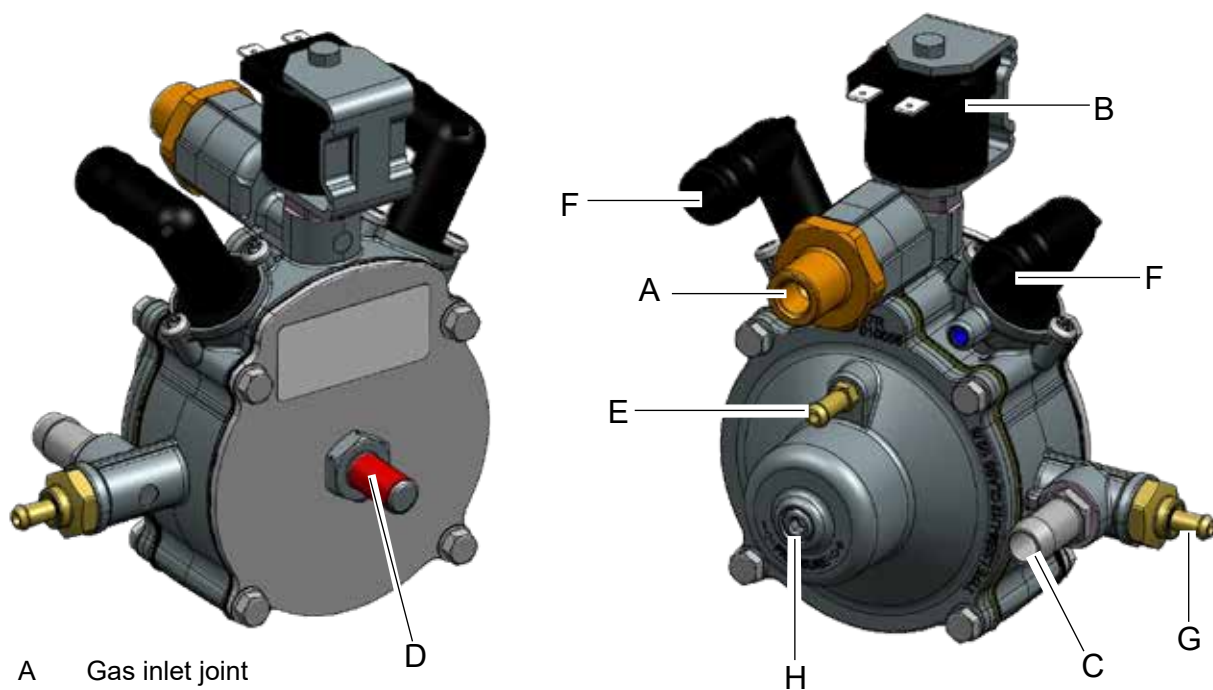

- A Gas inlet joint
- B Solenoid valve
- C Gas outlet joint
- D Mounting points for regulator
- E Compensation joint (MAP)
- F Joints for regulator heating
- G Overpressure joint
- H Pressure adjuster

The regulator comes already tested and calibrated. No further calibration is called for on installation. With the new regulator, a slight difference in pressure can be seen in the correct operating pressure. This is due to the rigidity of the "new" membranes. The new membranes quickly bed in and after a few days, the operating pressure will be constant.

The pressure of gas at the outlet can however be adjusted if necessary.

To measure the pressure of gas at the regulator outlet, connect a PC with specific software to the fuel management ECU.

For accurate measurement of the pressure, the engine must be:

- at operating temperature;
- running at tick- over speed;
- running on gas;

Use the screw "H" to adjust the gas pressure at the outlet. Turn the screw anti-clockwise to increase the pressure and clockwise to reduce it.

ATTENTION

Do NOT turn the screw more than 6 complete turns in either direction from its original position. If you are unable to obtain the pressure setting you want with these adjustments, check the filter, gas injectors, pressure sensor etc..

Changing the gas outlet pressure values from those set by the fuel management system neither improves nor worsens engine performance and/or fuel consumption.

PERIODICAL MAINTENANCE

Gas outlet pressure check.

Complete revision based on the type of pressure regulator and as described in the Use and Maintenance Handbook.

TEMPERATURE SENSOR (OPTIONAL)

Temperature sensors are supplied on request as optional extras.

When selecting the unit, you can choose from three different options (see details of connections in the “electrical connections” section):

- Optional use of sensor with connector.
- Connection with the original engine temperature sensor.
- Temperature sensor not fitted and no connection for ECU in signals.

The change-over from petrol to gas is managed by the fuel management ECU with specially programmed software.

On two-stage pressure regulators, we recommend fitting the temperature sensor to the hose going to the gas inlet joint; on single stage units, fit the sensor to the “hot” hose carrying heating system water.

Signals read by the sensor are sent to the ECU and form part of the overall data package needed to make the engine run on gas.

TECHNICAL DATA

Weight: 71 g

Pipes work connection: Ø 15 mm

Sensor type: 4,7 kΩ

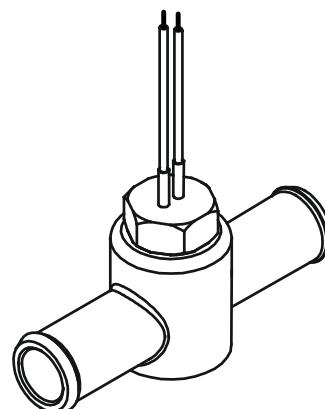

LR025 GAS PRESSURE/TEMPERATURE/VACUUM SENSOR

The intake manifold gas pressure/temperature/vacuum sensor works in combination with the ECU and “OMEGAS ” and “EVO ” injectors.

TECHNICAL DATA

Type of fuel: LPG

Homologation: E13 R67-01 0317 class 2

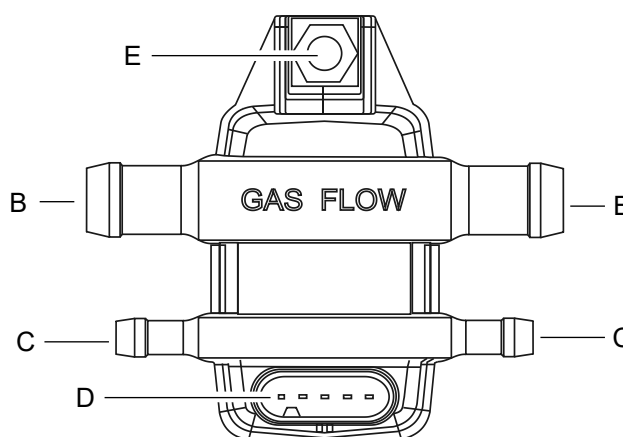
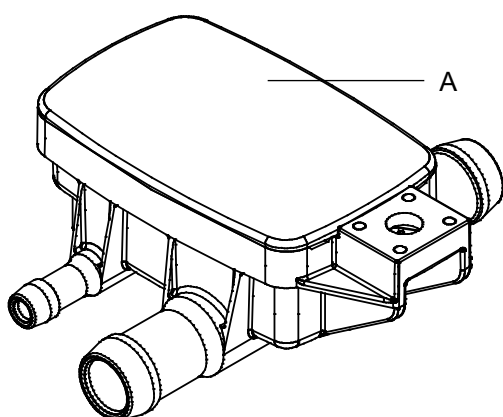

- A. Sensor housing
- B. Gas joint
- C. Vacuum joints (MAP)
- D. Connector
- E. Mounting points

FILTERS

Filters are supplied on request as optional extras.

Filters serve to filter LPG in its gaseous state.

Filters must be connected in series between the regulator and the pressure/temperature/vacuum sensor.

Filters house a cartridge that effectively filters the flow of gas from the outside to the inside.

Filter inlet/outlet joints are for use with pipes/hoses with an internal diameter of 14 mm.

FL-375-2 FILTER

Technical data

Weight	200 g
Degree of filtration	β10 [c] (ISO 16889) ≥ 75
Maximum operating pressure	4.5 bar
Homologation N°	E13 67R-010242
Cartridge	replaceable

FL-ONE FILTER

Technical data

Weight	75 g
Degree of filtration	10 micron
Maximum operating pressure	4.5 bar
Homologation N°	E13 67R-010278
Body and cartridge	disposable

FC 30 FILTER (COALESCING)

Technical data

Weight	90 g
Degree of filtration	10 micron
Maximum operating pressure	4.5 bar
Homologation N°	E4 67R-010286
Body and cartridge	disposable

F-781 FILTER

Technical data

Weight	52,4 g
Degree of filtration	10 micron
Maximum operating pressure	9.0 bar
Homologation N°	E20 67R-010906
Body and cartridge	disposable

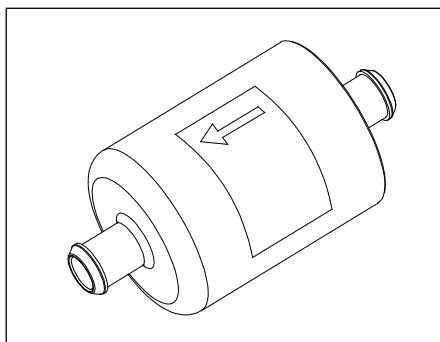

FL-375-2 FILTER

Dimensions

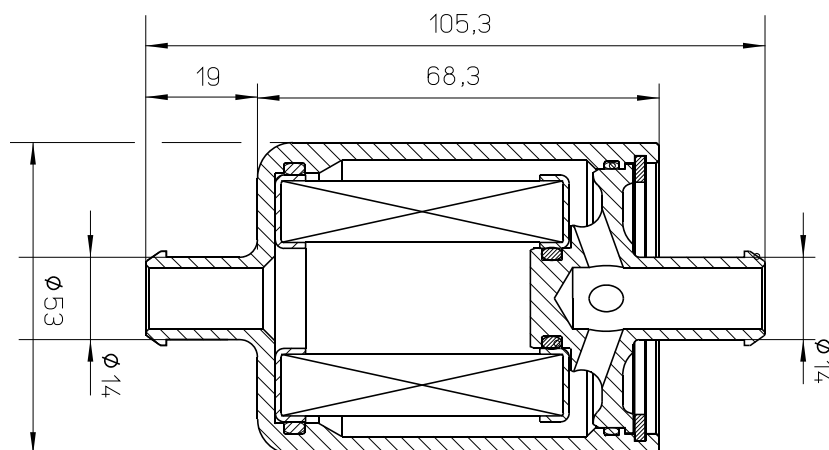

Cross section

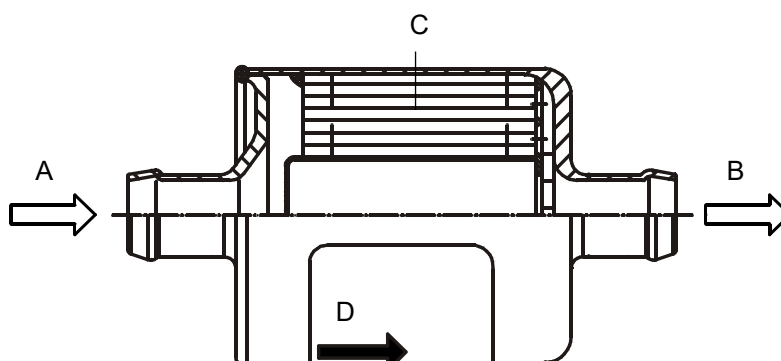

Label

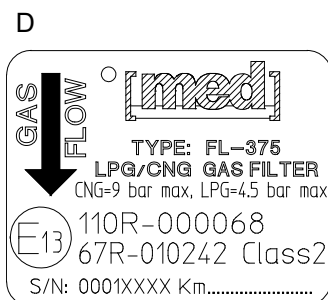

- A. Gas inlet
- B. Gas outlet
- C. Filter cartridge
- D. Label showing:
 - Modell
 - Gas flow rate
 - Homologation
 - Serial number
 - Km to service

Cartdrige replacing

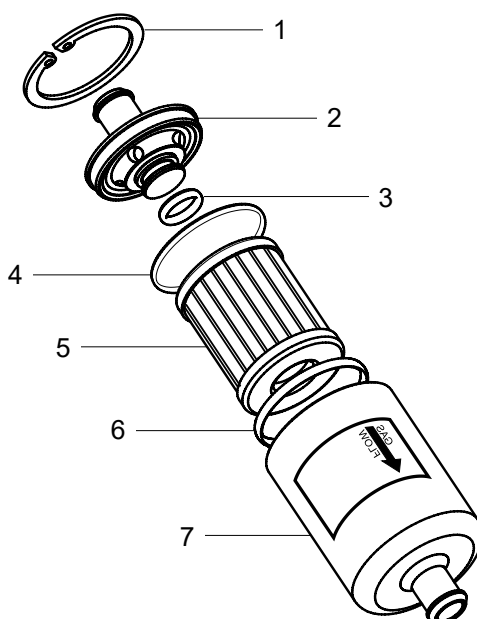

1. Seeger ring
2. Casing cover
3. Inlet O-Ring
4. Cartdrige O-Ring
5. Filter cartdrige
6. Cartdrige O-Ring
7. Casing

FL-ONE FILTER

Dimensions

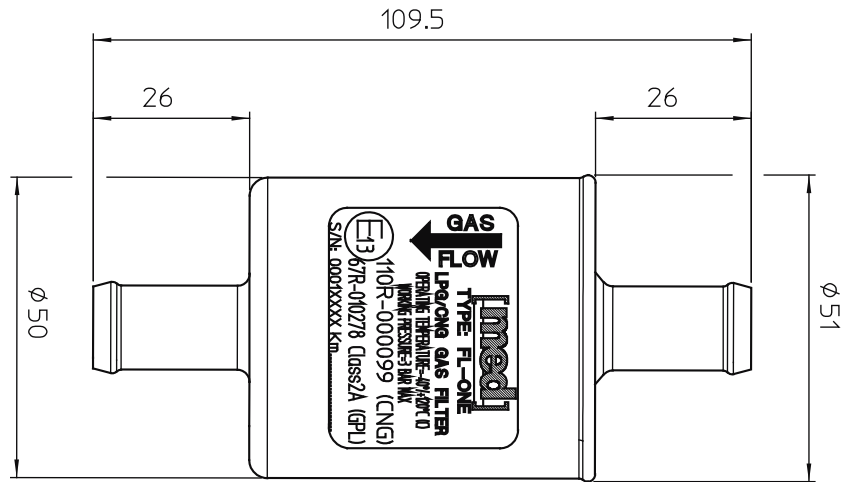

Cross section

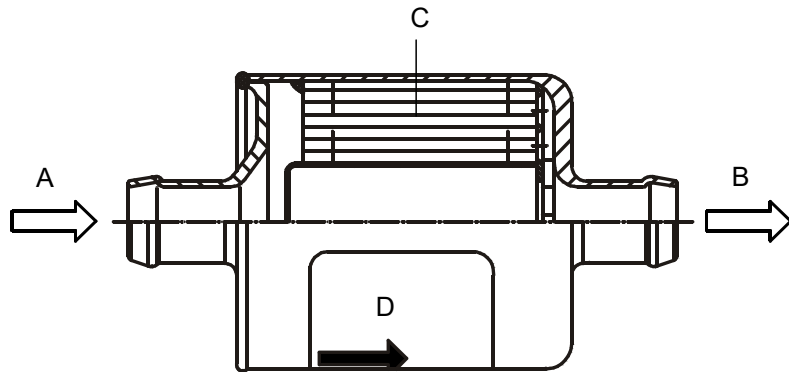

Label

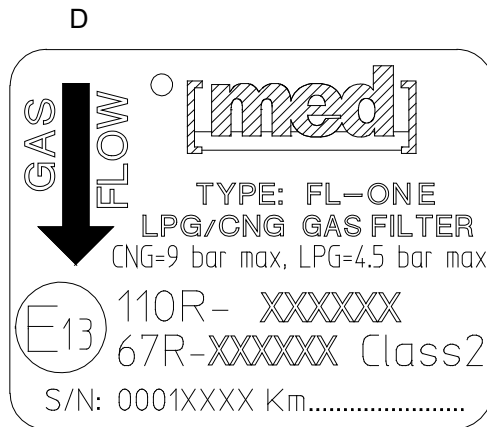

- A. Gas inlet
- B. Gas outlet
- C. Filter cartridge
- D. Label showing:
 - Modell
 - Gas flow rate
 - Homologation
 - Serial number
 - Km to service

FC 30 FILTER

Dimensions

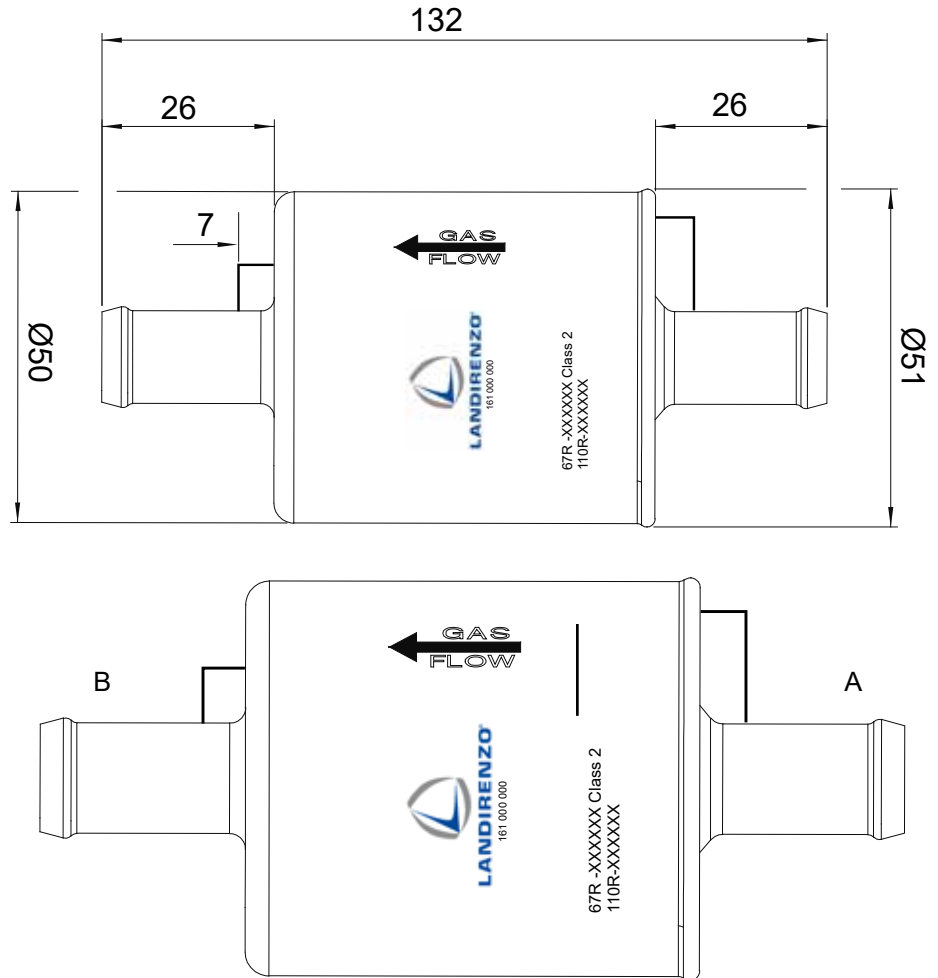

Label

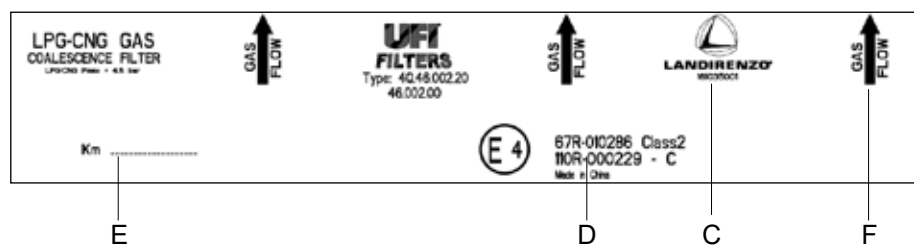

- A. Gas inlet
- B. Gas outlet
- C. Logo and code
- D. Homologation
- E. Km to service
- F. Gas flow



ATTENTION !

The coalescing filter FC-30 must be mounted in vertical position, as described in the section "Installing the filter".

F-781 FILTER

Dimensions

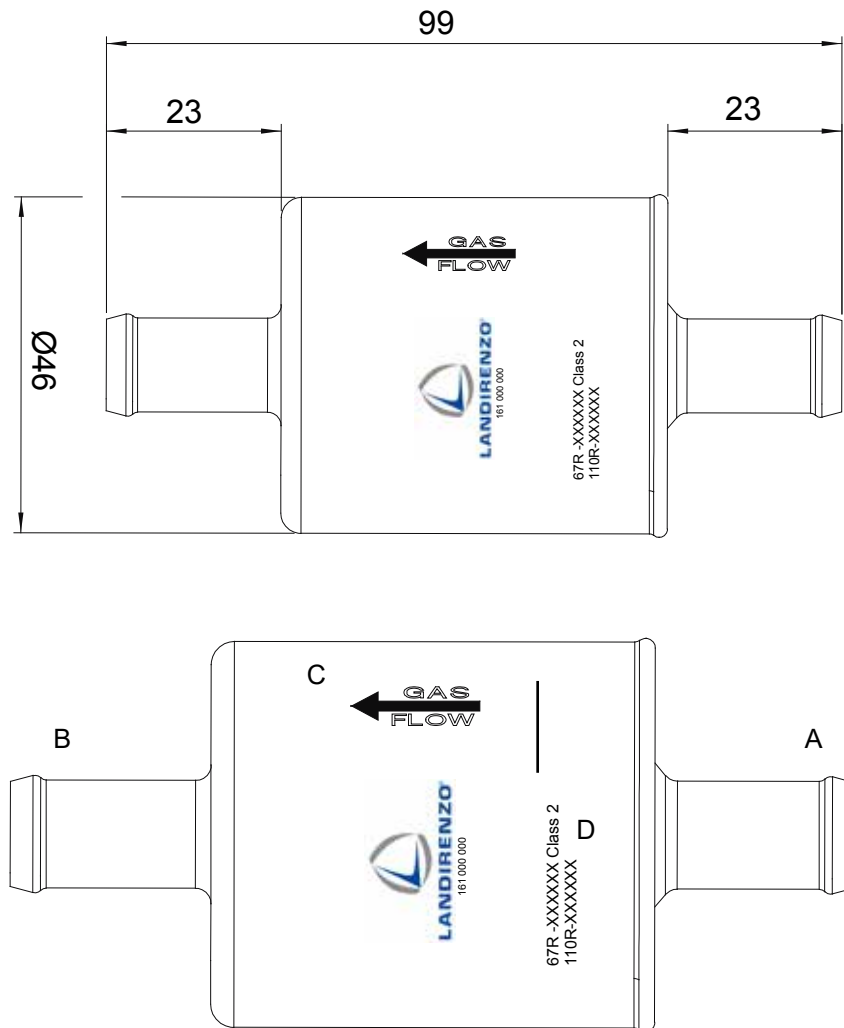

- A. Gas inlet
- B. Gas outlet
- C. Filter cartridge
- D. Label showing:
 - Modell
 - Gas flow rate
 - Homologation

FL01S FILTER

Dimensions

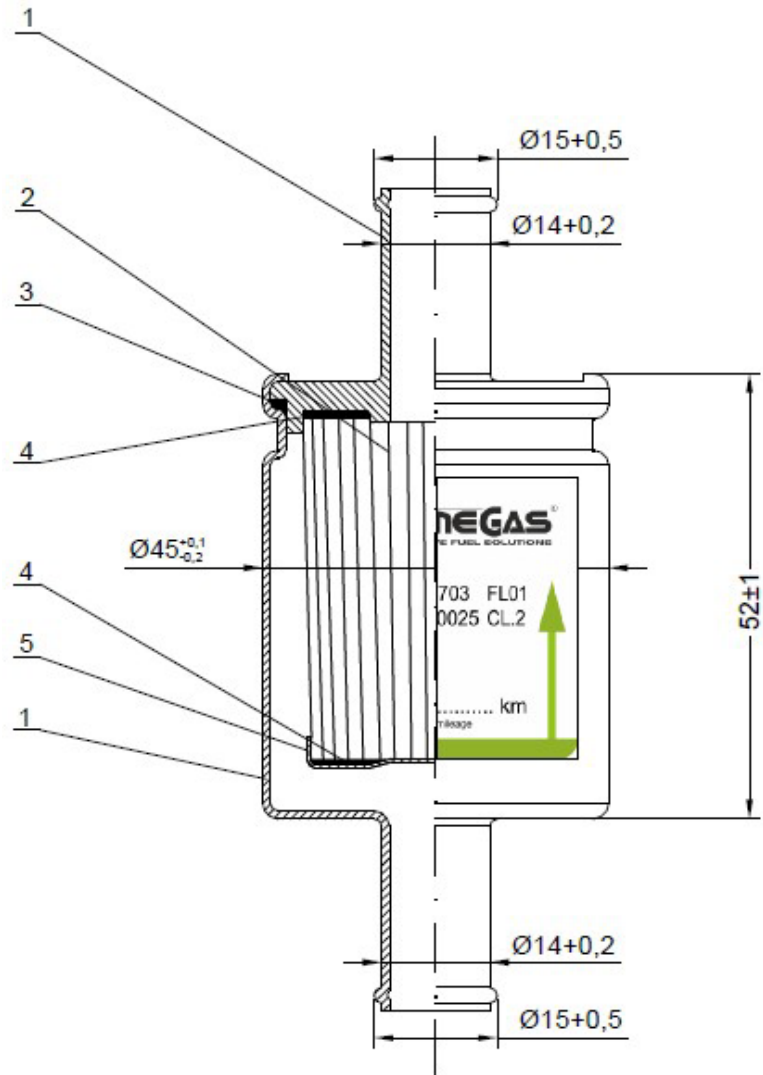

1. Housing (AL99.7%)
2. Filtration material: paper
3. O-ring: NBR70
4. Glue: PVC
5. Cartridge base: tinplate

GIRS12 GAS INJECTORS

The gas from the filter goes into Joint "A" then floods the injector unit common chamber.

The metered gas is expelled from the injectors through nozzles "B" and arrives through special ducting in the intake manifold then into the engine.

The injectors are governed by the gas ECU and are linked to it with the "D" connectors.

Thanks to five sizes, injectors may be fitted to different displacement and power engines.

The size of plastic injectors is indicated under its body by a numerical code. The higher an injector's number, the higher the flow rate. Injectors with a metal casing have interchangeable nozzles.

Maximum Engine Power [kW]		N° CYLINDERS					
		2	3	4	5	6	8
GIRS12 Injector Size	XXS	-> 30	-> 46	-> 61	-> 77	-> 92	-> 123
	XS	30 - 37	46 - 56	61 - 74	77 - 93	92 - 112	123 - 150
	S	37 - 44	56 - 66	74 - 88	93 - 110	112 - 132	150 - 176
	M	44 - 57	66 - 85	88 - 114	110 - 143	132 - 171	176 - 229
	L	57 ->	85 ->	114 ->	143 ->	171 ->	229 ->

The table shows the data acquired from the installation of a series of engines (*), however, once installation has been completed, a check can be carried out to make sure that the right size of injector has been fitted:

1. Calibrate the GAS system correctly;
2. Stabilise tick-over running on GAS;
3. Check the GAS injection time:
 - if this time is between 4.5 ms and 6.0 ms, the installed injectors are fine;
 - if the time is less than 4.5 ms, the injectors are too big;
 - if the time is longer than 6.0 ms, the injectors are too small.

* with operating pressure of 2 bar; with different pressures, each $\pm 1/3$ bar changes the size of injector by plus or minus one.

- A. Gas inlet joint
- B. Gas outlet nozzles
- C. Injectors
- D. Injector connectors
- E. Injector size
- F. Injector casing
- G. Homologation
- H. Mounting points for injector units

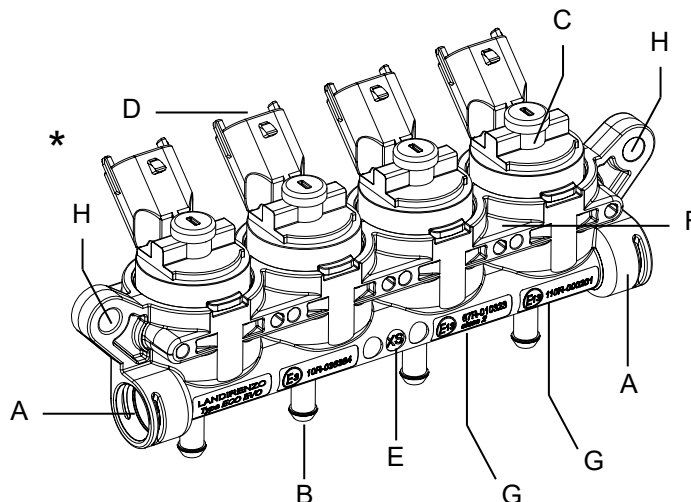

* The injector rail is available in version for 2-3-4-cylinders engines.

TECHNICAL DATA

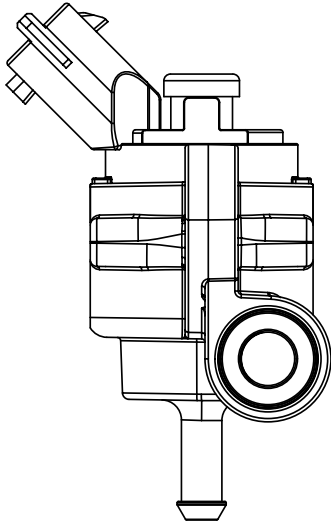

SIZES	XXS	XS	S	M	B
COLOR CAP	BROWN	YELLOW	GREEN	BLACK	WHITE
TYPE OF INJECTOR	normally closed				
GAS INLET	side feed				
WORKING PRESSURE	0,8 ÷ 4,5 bar				
ENDURANCE	300 millions of cycles				
COIL RESISTANCE	1,084 ohm				
PEAK CURRENT	7 A				
MAINTENANCE CURRENT	1,5 A peak&hold				
VOLTAGE WORKING	9/16 V				
OPENING TIME	1,8 ms				
CLOSING TIME	1,5 ms				
OPERATING TEMPERATURE	-40°C / +120°C				
LINEARITY	+/- 8%				
REPEATABILITY	+/- 9%				
HOMOLOGATIONS	E3 10 R - 036384				
	E13 110 R - 010201				
	E13 67 R - 010323				

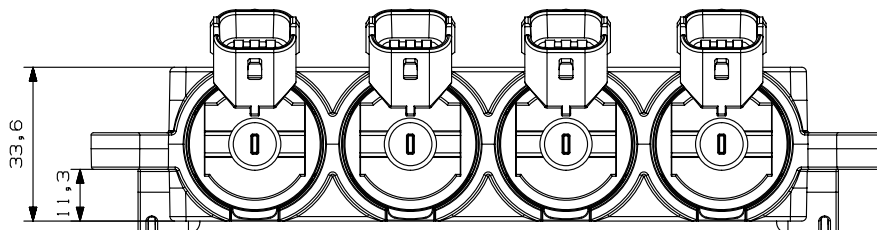
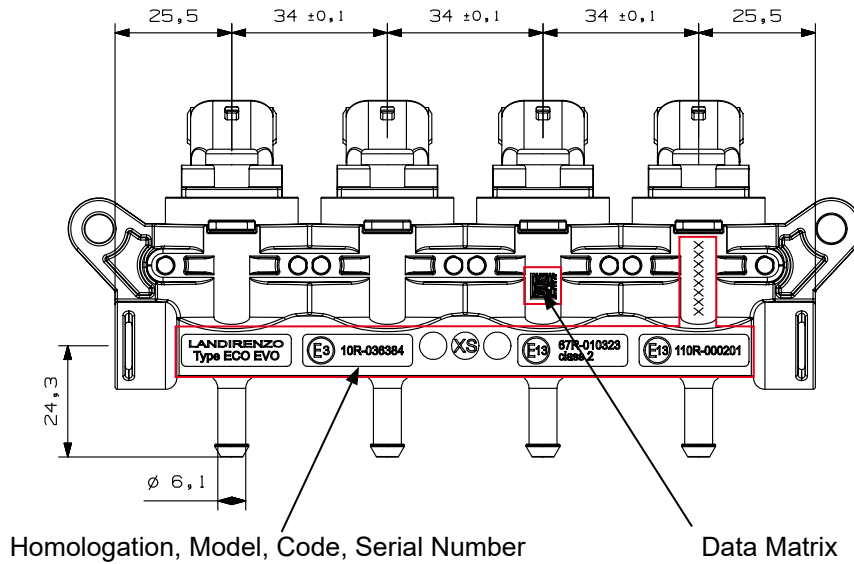

NOZZLES

INJECTOR NOZZLES

Nozzle for connection between the gas injectors and various branches of the intake manifold. The version of nozzle can be changed to match what the system requires.

Technical data (fig. A-B)

Connector hole diameter:	Ø 4 mm
Connection with pipes/hoses with internal diameter of:	Ø 6 mm
Threads:	M6 x 1
Manifold hole:	plastic Ø 4,75 mm - metal Ø 5 mm
Tightening with:	3.5 mm Allen wrench
Thread type:	conical (vers. A) / flat (vers. B)

Technical data (fig. C)

Connection with pipes/hoses with internal diameter of:	Ø 6 mm
Threads:	PTFE (teflon) Ø ext. 6mm - Ø int. 4mm
Manifold hole:	M10 x 1
Tightening with:	plastic Ø 8,75 mm - metal Ø 9mm
Thread type:	13 mm wrench

COMPENSATION NOZZLE

Nozzle for connecting compensation pipe/hose between the regulator and the intake manifold.

Technical data (fig. D)

Connector hole diameter:	Ø 3 mm
Connection with pipes/hoses with internal diameter of:	Ø 5 mm
Threads:	M6 x 1
Manifold hole:	plastic Ø 4,75 mm - metal Ø 5 mm
Tightening with:	7 mm hex wrench
Thread type:	flat

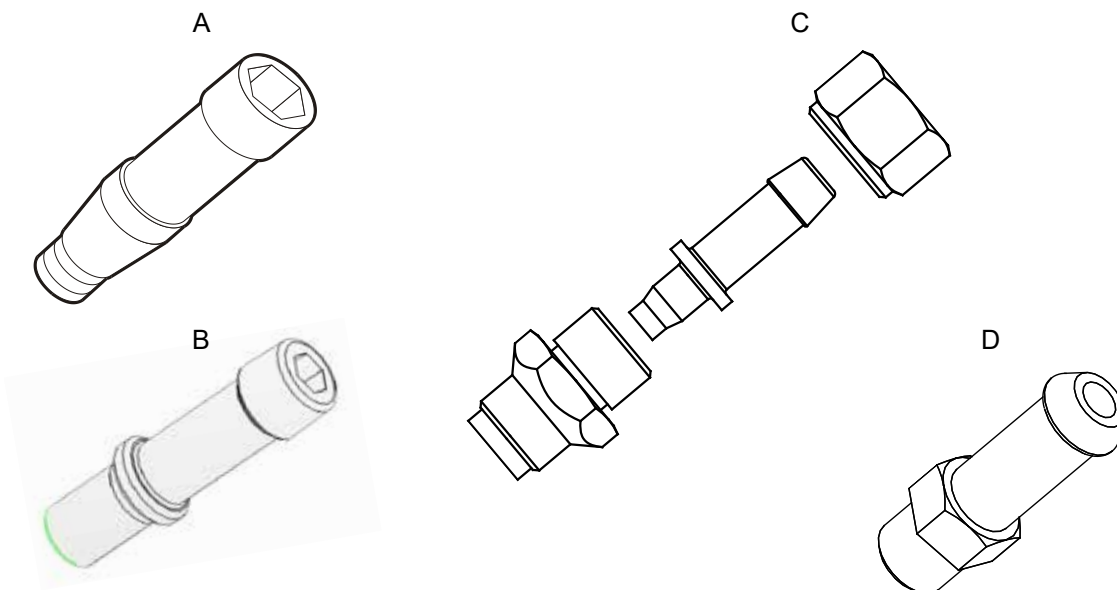

EVO GAS INJECTORS

The gas from the filter goes into Joint "A" then floods the injector unit common chamber. The metered gas is expelled from the injectors through nozzles "B" and arrives through special ducting in the intake manifold then into the engine. The injectors are governed by the gas ECU and are linked to it with the "D" connectors.

Injector rails are provided of interchangeable nozzles (not included with the rails) which define the gas flow (not needed longer use rails of different size to retrofit engines of different power but just match the rail with suitable nozzles).

The size is marked on the side of nozzles for metal ones (number define the orifice diameter, the highest the diameter the highest the flow). Plastic nozzles sizes are identified by the color, for the correspondence color-size see the chapter "Mounting nozzles"

The table shows the data acquired from the installation of a series of engines (*), however, once installation has been completed, a check can be carried out to make sure that the right size of injector gas been fitted:

INJECTOR SIZES					
		kW / cylinder			
		10 - 15	15 - 20	20 - 25	over 25
cc / cylinder	200 - 280	1.8	1.8		
	290 - 370	2	2	2.2	
	380 - 440	2	2.2	2.2	
	450 - 500		2.2	2.4	2.6
	over 510			2.6	2.6

- 1) Calibrate the GAS system correctly;
- 2) Stabilise tick-over running on GAS;
- 3) Check the GAS injection time:
 - if this time is between 4.5 ms and 6.0 ms, the installed injectors are fine;
 - if the time is less than 4.5 ms, the injectors are too big;
 - if the time is longer than 6.0 ms, the injectors are too small.

*With operating pressure of 1 bar. Each $\pm 1/4$ bar, switch to a smaller size or large size.

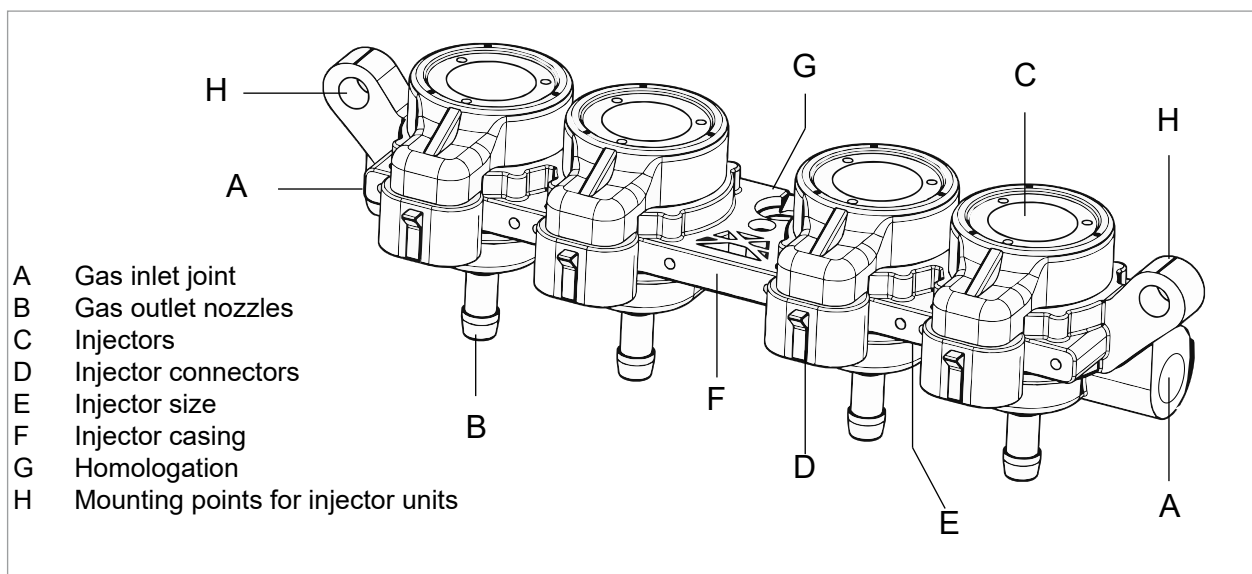

Injectors with metallic case

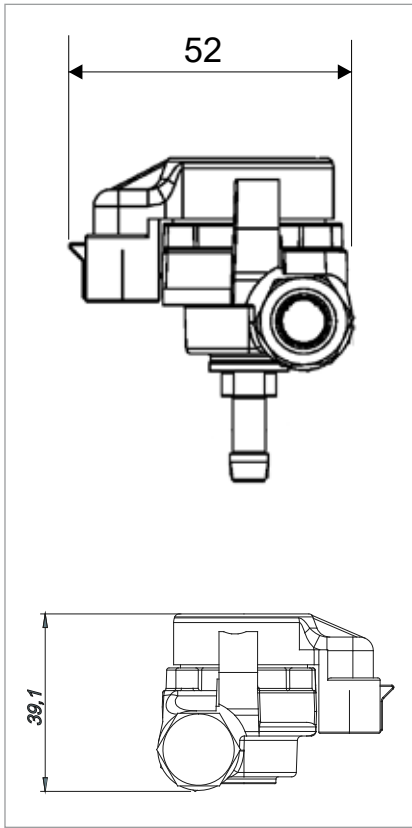

TECHNICAL DATA

SIZES	1.6	1.8	2.0	2.2	2.4	2.6
WEIGHT	442 g					
TYPE OF INJECTOR	normally closed					
GAS INLET	side entrance					
WORKING PRESSURE	0,5 ÷ 4,5 bar					
ENDURANCE	300 millions of cycles					
COIL RESISTANCE	1,96 ohm					
PEAK CURRENT	4,4 A					
MAINTENANCE CURRENT	2 A peak&hold					
VOLTAGE WORKING	4,5/13,5 V					
OPENING TIME	2,45 ms					
CLOSING TIME	1,9 ms					
OPERATING TEMPERATURE	-20°C / +120°C -40°C / +120°C (metal version)					
HOMOLOGATIONS	E13 67 R - 010290 E13 110 R - 000123 E3 10 R - 046345					

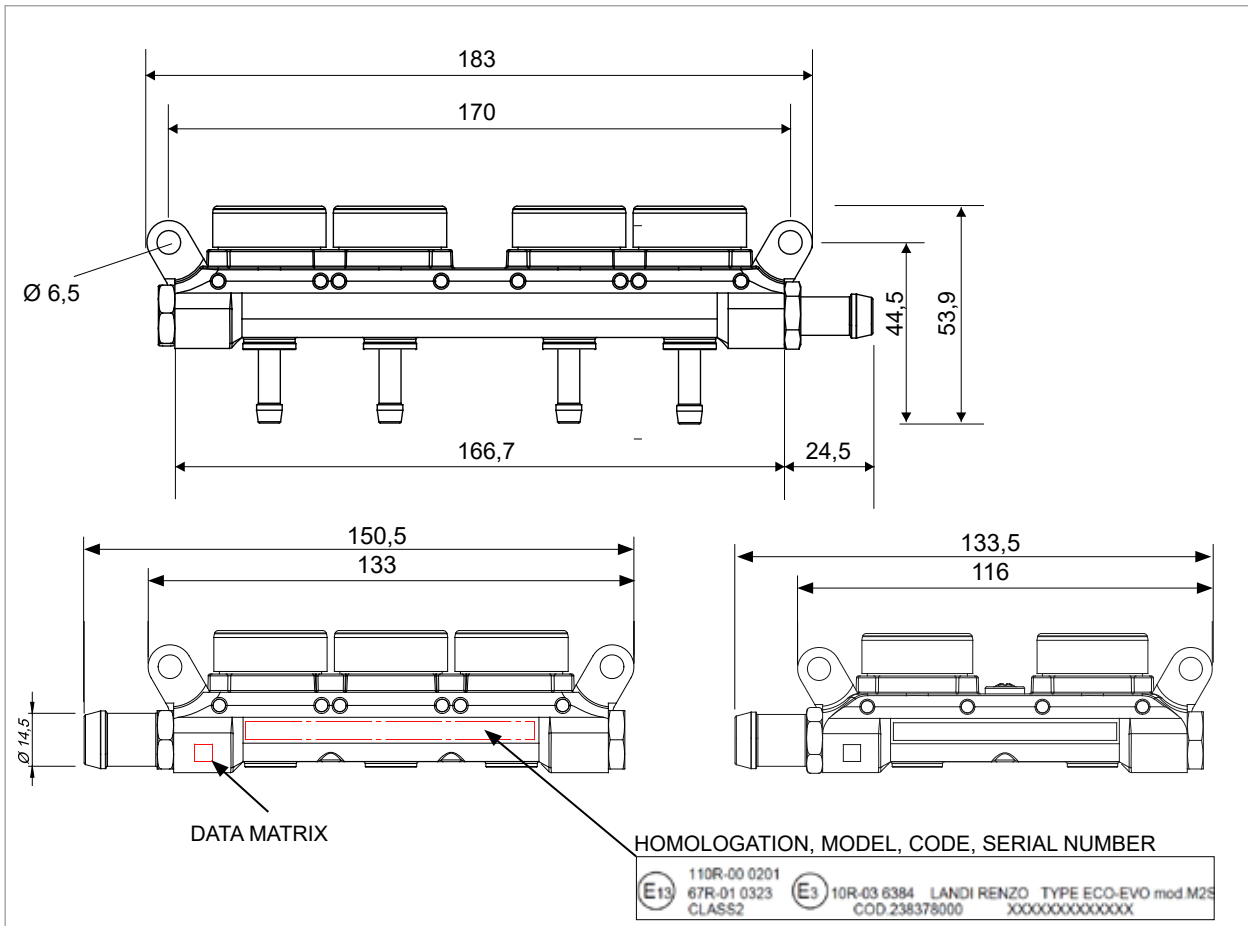

Injectors with plastic case

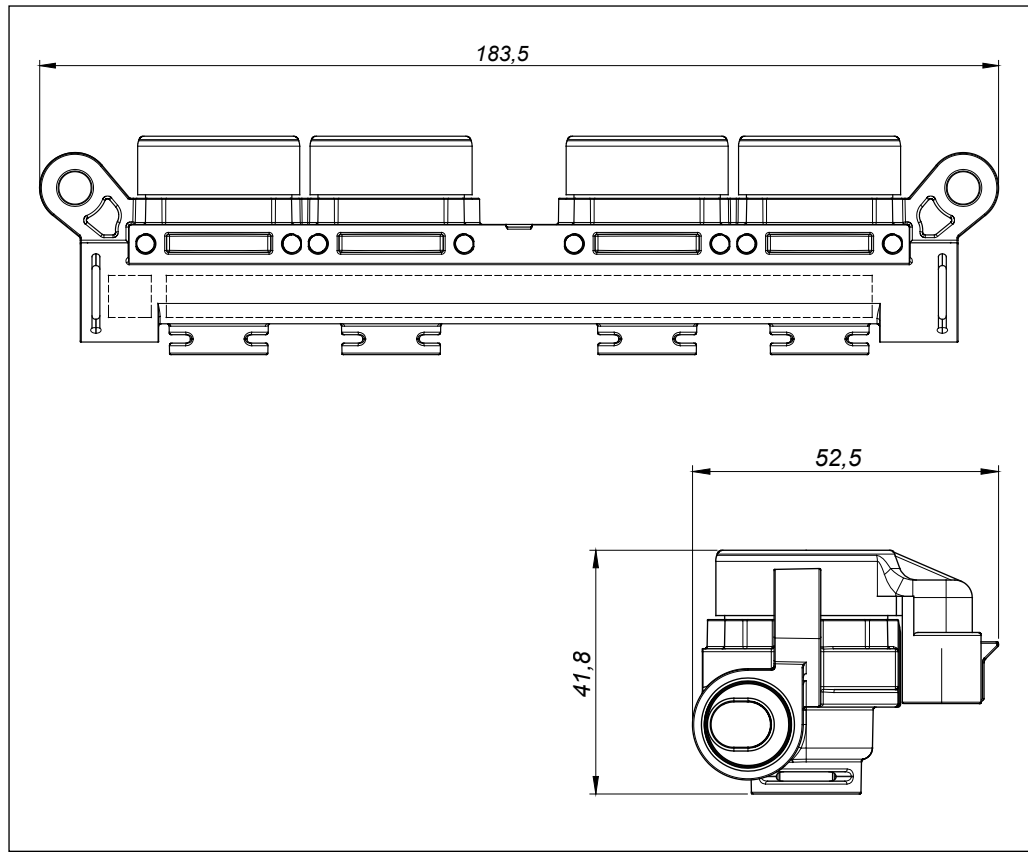

NOZZLES FOR INJECTORS RAIL

Calibrated nozzles for injector rails with metal casing.

The size of the injectors is indicated by a number. The higher the number, the higher the flow rate.

Calibrated nozzles for injector rails with plastic casing.

The size of the injectors is indicated by a color.

color	size
RED	1.6
YELLOW	1.8
GREEN	2.0
BLACK	2.2
WHITE	2.4
GREY	2.6

To make sure that you install the right size of nozzle, check with the table above and follow the verification procedure.

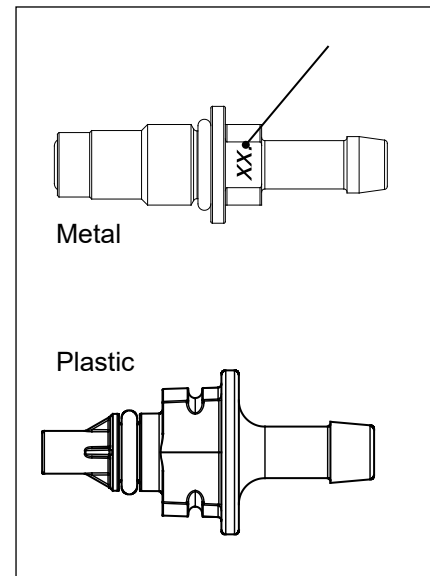

EP GAS INJECTORS

The gas from the filter goes into Joint "A" then floods the injector unit common chamber.

The metered gas is expelled from the injectors through nozzles "B" and arrives through special ducting in the intake manifold then into the engine.

The injectors are governed by the gas ECU and are linked to it with the "D" connectors.

For the correct size of the injectors it is necessary to drill the nozzles by using calibrated tips. (see Table).

MEASURING DRILLING NOZZLES	
Ø mm	Engine displacement (cc)
1,4	800 - 1000
1,6	1000 - 1200
1,8	1200 - 1500
2.0	1500 - 1800
2,2	1800 - 2100
2,4	2100 - 2400
2,6	2400 - 2600

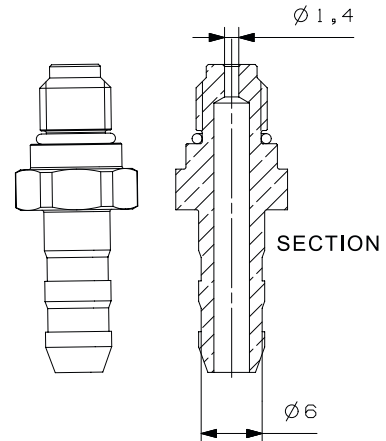

At the end of the installation it is possible to check the correct size of the injector installed:

1. Calibrate the GAS system correctly;
2. Stabilise tick-over running on GAS;
3. Check the GAS injection time.

IMPORTANT:

- The injection time at the idle must be at least 5.5 ms, without applied engine loads (climate, lights, etc.).
- At the pressure of 1 bar , 0.2 mm on the diameter increase-decrease the time to the idle of about 1 ms.
- This table gives a general indication of the nozzle size. Special motorizations (Valvetronic, Valvematic, Multiair, etc.) require different nozzle sizes.
- The layout can be changed simply by removing the stop rings from the body, change the connections as needed and reposition the stop rings in the body with a slight push.

- A. Gas inlet joint
- B. Gas outlet nozzles
- C. Injectors
- D. Injector connectors
- E. Plug
- F. Injector casing
- G. Homologation
- H. Mounting points for injector units

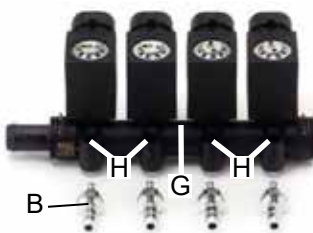
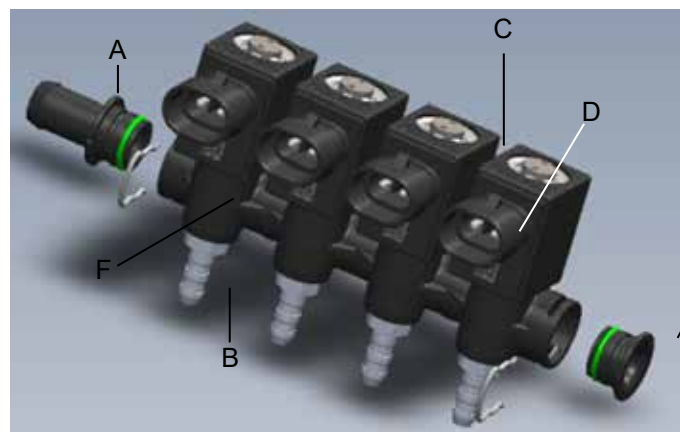

ATTENTION:

To remove the stop rings correctly, use a flat-blade screwdriver and pry the center of the ring. Once the installation operations have been completed, check for leaks on all the electro-injector joints using a leak detector and / or soapy water.

TECHNICAL DATA

SIZES	1.4	1.6	1.8	2.0	2.2	2.4	2.6
INJECTOR TYPE	normally closed						
GAS SUPPLY	side entrance						
WORKING PRESSURE (RELATIVE)	0,5 ÷ 4 bar						
COIL RESISTANCE	3 ohm						
PEAK CURRENT	4 A						
CURRENT MAINTENANCE	1,5 A peak&hold						
WORKING VOLTAGE	10/14 V						
OPENING TIME	3,3 ms						
CLOSING TIME	2,8 ms						
WORKING TEMPERATURE	-20°C / +100°C						
ENDURANCE	> 200 million cycles						
OMOLOGATION	E3 10 R-034065 E13 110 R-010081 E13 67 R-010194						

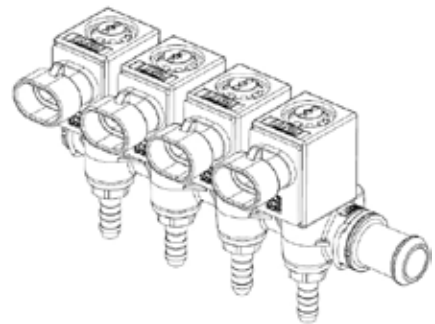
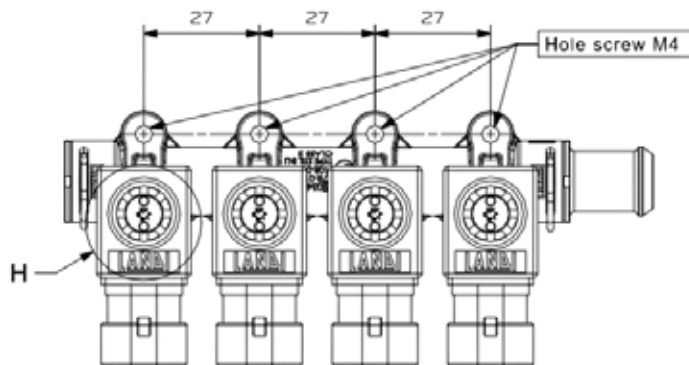
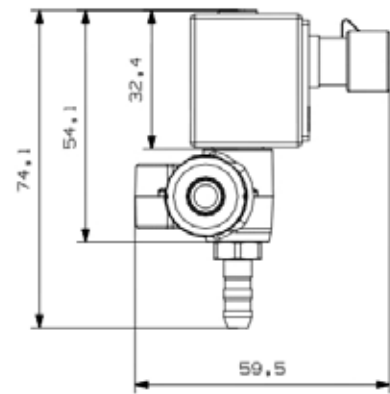
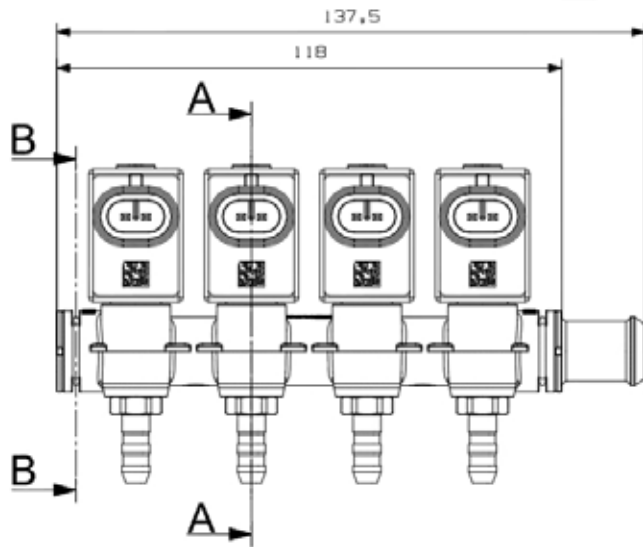

GI25 RAIL INJECTORS

The gas injectors are made in 4 different versions of the gas flow. Externally they are identified by the color of the cap "E". The various supports are provided for 2.3 and 4 injectors with and without gas pressure and temperature sensor "I".

The complete injectors groups of P/T gas are matched exclusively to AEB3000 unit.

The injectors groups without sensor P/T gas are used with control units 108 E 60.

The gas coming from the filter, it enters into the fitting "A" and invades the common chamber in the injector group.

Suitably dosed the gas exits from the injectors through the nozzles "B" and arrives, via a specific connection, to the intake manifold, reason always to the engine.

The injectors are driven by the gas control unit are connected to it through the "D" connectors.

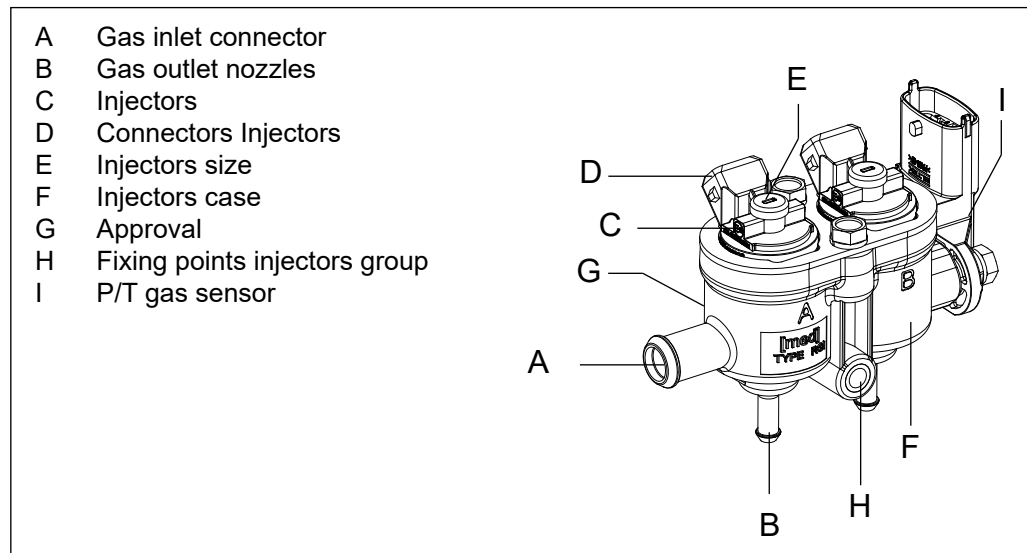

fig. I1

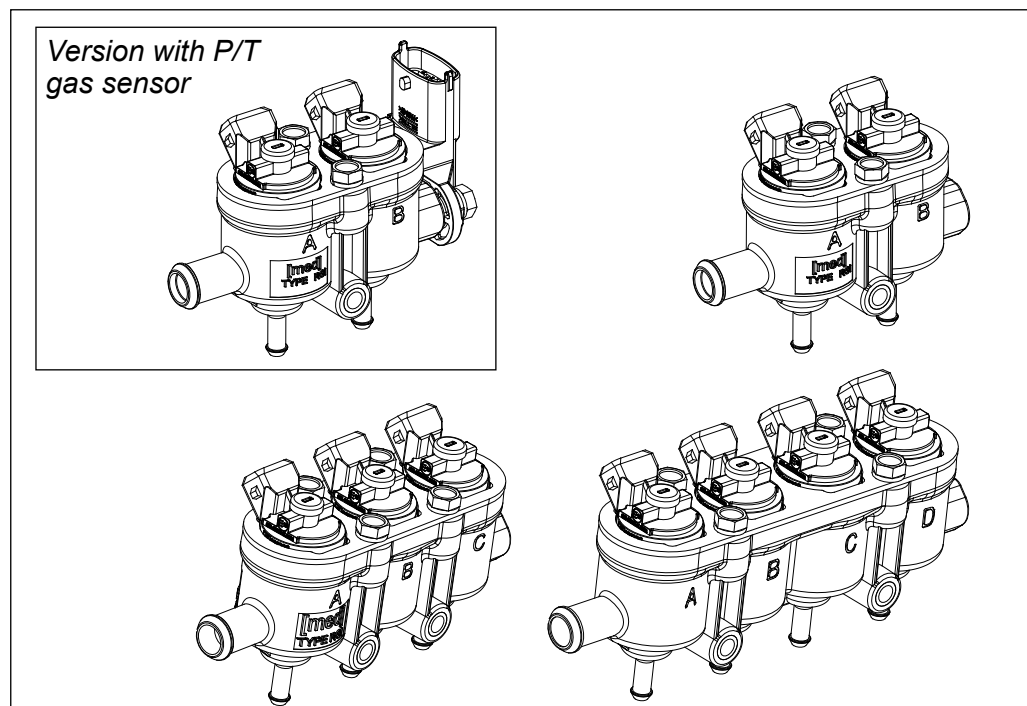

fig. I2

Dimensions

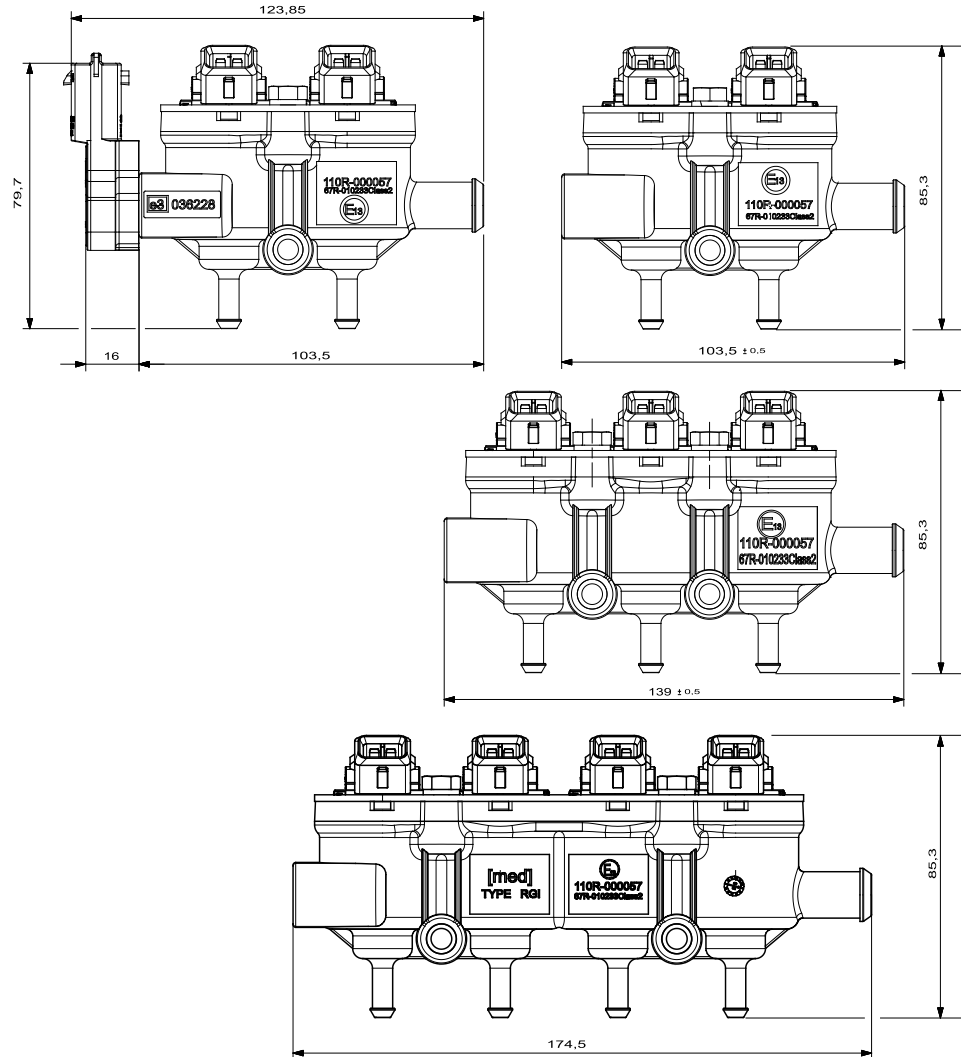

fig. I3

SINGLE GAS INJECTOR

Identification

The gas injectors are subdivided by volume flow of gas, in order to facilitate the calibration of the gas system. The size of the injectors can be identified by the cover on each one (see table in Fig. I5).

Little size:	<17 kW for engine cylinder
Medium size:	15-27 kW for engine cylinder
Big size:	25-40 kW for engine cylinder

On the same injector assembly, it is not possible to use injectors of different sizes, as well as the combination of injectors of 1st and 2nd versions.

TECHNICAL DATA

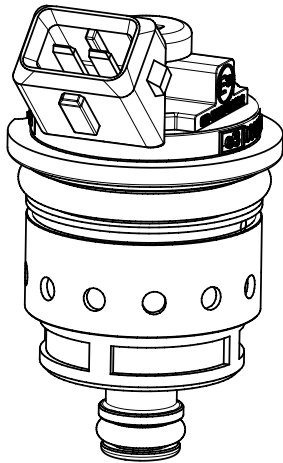
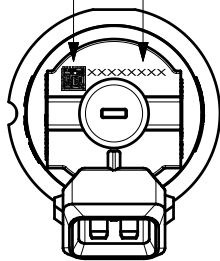

fig. 14

Data matrix Serial number



DIMENSION	2,0 mm	2,2 mm	2,5 mm	2,8 mm
FUEL TYPE	LPG , CNG			
TYPE OF INJECTOR	normally closed			
GAS INLET	lateral entry			
WORKING PRESSURE	0,8 ÷ 3 bar			
TEST PRESSURE	10 bar			
COIL RESISTANCE	1,084 ohm			
PEAK CURRENT	6 A			
MAINTENANCE CURRENT	1,5 A peak&hold			
VOLTAGE WORKING	6/16 V			
MAXIMUM FREQUENCY	200 Hz			
MAXIMUM TIME CURRENT	2,2"			
OPENING TIME	1,7 ms			
CLOSING TIME	1,5 ms			
OPERATING TEMPERATURE	-40°C / +120°C			
FLOW RATE STATIC SIZE 1	2,04 g/s @ 0,95 bar			
FLOW RATE STATIC SIZE 2	2,62 g/s @ 0,95 bar			
FLOW RATE STATIC SIZE 3	3,07 g/s @ 0,95 bar			
LINEARITY	+/- 3%			
RIPEATABILITY	+/- 5%			
DURATION	300 milioni di cicli			
HOMOLOGATIONS	E13 67R-010233			
	E13 110R-000057			
	E3 10R-036318			

The size of the injectors can be identified by the cover on each one.

fig. 15

TYPE	SIZE		4 HOLES	12 HOLES
			COLOR CAP	
Size 1 (2,0 mm) @ 1 bar-rel	XS	25-20	YELLOW	GREY
Size 2 (2,2 mm) @ 1 bar-rel	S	25-22	GREEN	ORANGE
Size 3 (2,5 mm) @ 1 bar-rel	M	25-65	BLACK	BLUE
Size 4 (2,8 mm) @ 1 bar-rel	B	25-80	WHITE	VIOLET

fig. 16

35,3

61,9

Dimensions

GI-VS19 RAIL INJECTORS



DESCRIPTION

The GI-VS19 Rail injector is characterized by the ease of installation thanks to the different configurations possible combined with reduced dimensions and lightness.

The new product exploits the latest innovations in terms of elastomers and anti-friction treatments that guarantee a long life even in chemically aggressive environments.

Thanks to the extremely reduced dimensions, the GI-VS19 injectors can be installed in many combinations, always adapting in the best way to the space available in the engine compartment.

The new 2.6Ω coil and the new technical solutions of the internal components allow to obtain an opening time of only 2.8ms at 2bar, ensuring the best gas dosage in all driving conditions.

The 90 ° Super Seal connector ensures high performance in terms of water and dust resistance and reduces wiring stress.

Various sizes available with brass nozzles (see tab size nozzles) and 2 different stroke settings to guarantee the best range of flow rates.

SIZE NOZZLES	
Nozzle	cm3 for single cyl.*
A1 (1,4mm)	200 - 210
A (1,6mm)	220 - 250
B (1,8mm)	260 - 320
C (2,0mm)	330 - 400
D (2,2mm)	410 - 430
E (2,4mm)	440 - 470
F (2,6mm)	480 - 500
G (2,8mm)	510 - 550
H (3,0mm)	> 550

*Indicative values

ENDURANCE

200 million cycles

HOMOLOGATIONS

E3 10 R-034065
E13 110 R-010081
E13 67 R-010194

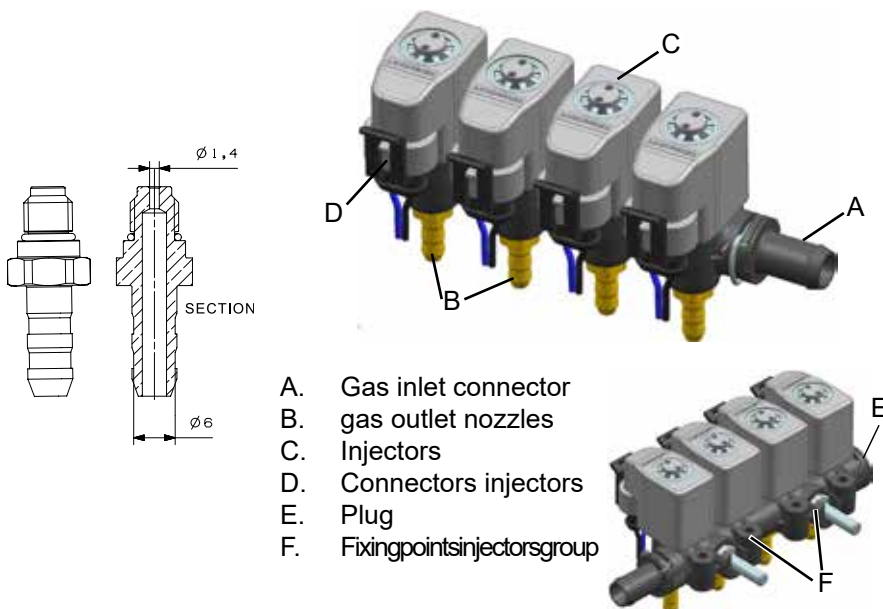

- A. Gas inlet connector
- B. gas outlet nozzles
- C. Injectors
- D. Connectors injectors
- E. Plug
- F. Fixing points injector group

TECHNICAL SPECIFICATIONS

NOZZLE SIZE	1.4	1.6	1.8	2.0	2.2	2.4	2.6	2.8	3.0
FUEL TYPE	LPG , CNG								
INJECTOR TECHNOLOGY	Side feed, normally closed								
CONTROL TYPE	Peak & Hold command								
WORKING PRESSURE	0,5 ÷ 5,5 bar								
REPEATABILITY	±10% (Tj: 4 – 20ms)								
LINEARITY	±6% (Tj: 4 – 20ms)								
WORKING VOLTAGE	9/16 V								
COIL RESISTANCE	2,6 Ohm ±7%								
STROKE	0,5±0,02 / 0,7±0,02 mm								
OPENING TIME	2,8 ms								
CLOSING TIME	2,2 ms								
OPERATING TEMPERATURE	-20°C / +120°C								
DIMENSION	138x75x54 mm								
WEIGHT	345 g								
STATIC FLOW RATE	0,57 to 2,41 g/s (CNG @ 3bar)								
MIN INJECTION TIME	4 ms (linearity)								

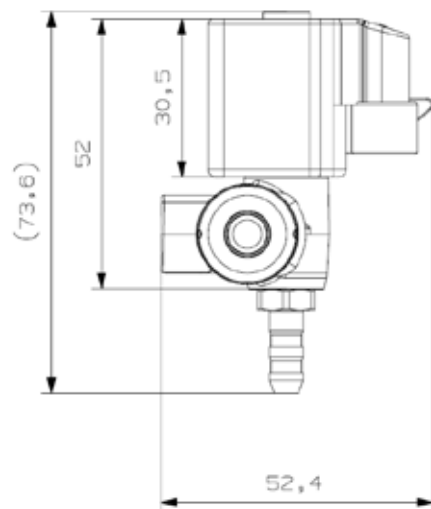
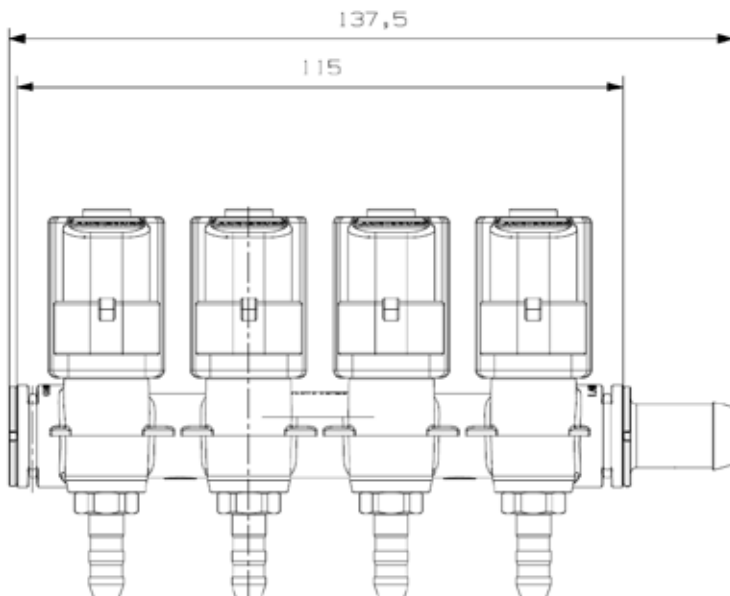

LANDIRENZO OMEGAS 4.0 ECU (2-3-4 CYLINDERS)

LANDIRENZO OMEGAS 4.0 is electronic ECU (2-3-4 cylinders) that manage the supply of gas on vehicles with multipoint injection systems. The ECU uses various signals from the petrol injection ECU (see “Operating Principle“ section) to recalculate the right fuel metering for the vehicle, to manage the switch from petrol to gas and vice versa in the event of running out of gas.

Thanks to the communication with the OBD protocol, it can reads some parameters from the original petrol ECU to adapt the system in order to compensate the drifts and the aging of the Gas components. The OBD connection also allows the monitoring of various engine parameters directly from the calibration software and any errors in the engine control system.

It features an auto-diagnostic system and manages changing back to petrol in the event of a fault.

SIGNALS FROM THE ENGINE

- Petrol injection times
- Radiator coolant temperatures
- Intake manifold vacuum readings
- Lambda probe
- Engine speed
- Battery voltage
- OBD (only on LANDIRENZO OMEGAS system)

SIGNALS FROM GAS SYSTEM COMPONENTS

- Gas pressure
- Gas temperature
- Fuel level sensor

GOVERNING GAS SYSTEM COMPONENTS

- Fuel switch
- Fuel level indicator
- Regulator solenoid - solenoid(s) tank(s)
- Gas injectors

FUNCTIONS

- Deactivation and emulation of petrol injectors
- Reading engine speed also from hall effect phonic wheel sensors
- External relay command for petrol pump exclusion
- Communication with OBD
- Lambda probe emulation (optional, only if necessary)

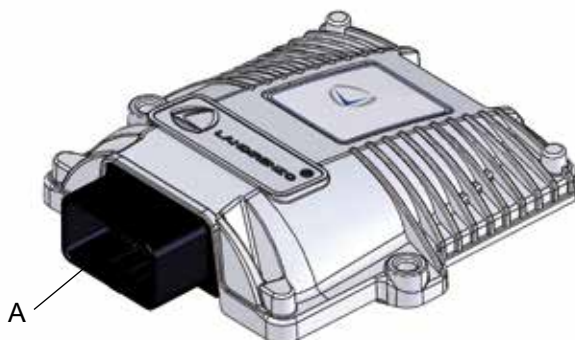

- A. Connector
- B. Homologation
- C. Mounting points

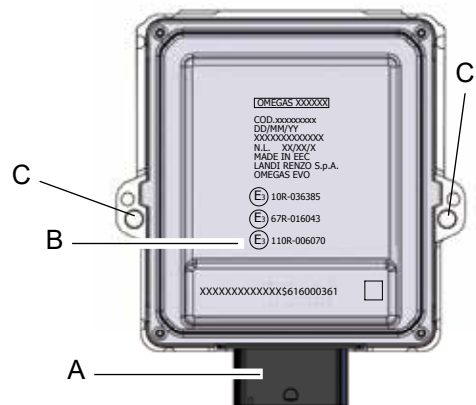

TECHNICAL DATA

GAS TYPE AND NUMBER OF CYLINDERS	LPG, CNG - 2÷4
CASE	METALLIC
SUPPLY VOLTAGE:	10 ÷ 16 V
MAX CURRENT WITH ACTUATORS OFF :	≤ 0.5 A
STANDBY MAX CURRENT :	≤ 50 µa
DRIVER INJECTORS:	4
SOLENOID VALVES OUTPUT:	2
MAXIMUM CURRENT (FOR SINGLE OUTPUT):	2A*
FLASH MEMORY :	128 kb
PROCESSOR SPEED (pll):	50 MHz
WEIGHT :	196 g
DIMENSION:	134x152x36 mm
WORKING TEMPERATURE:	-40°C ÷ 110°C
CLASS IP :	IP6K9K
ECU CONNECTOR:	48 PIN
HOMOLOGATION:	E3 67R-016043 - E3 110R-006070 - E3 10R-036385

* in case of multiple solenoid valves on the cylinders, use the RELAY KIT for E.V. REAR (ex. KF378 AEB or additional relays of adequate capacity for the current required).

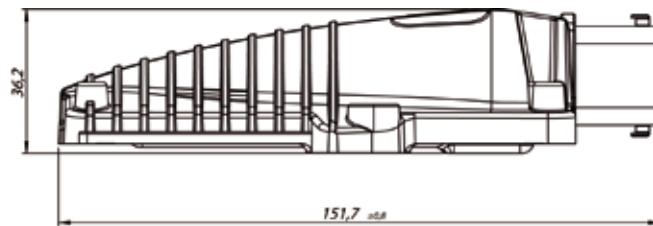

OMEGAS 4.0

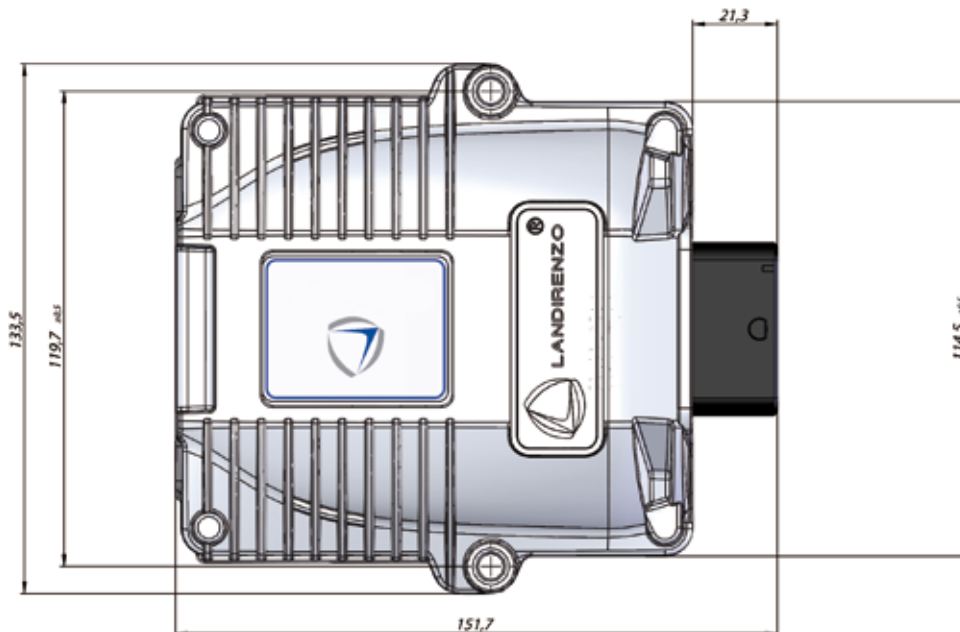

OMEGAS 4.0 WIRING PIN-OUT (2-3-4 CYLINDERS)

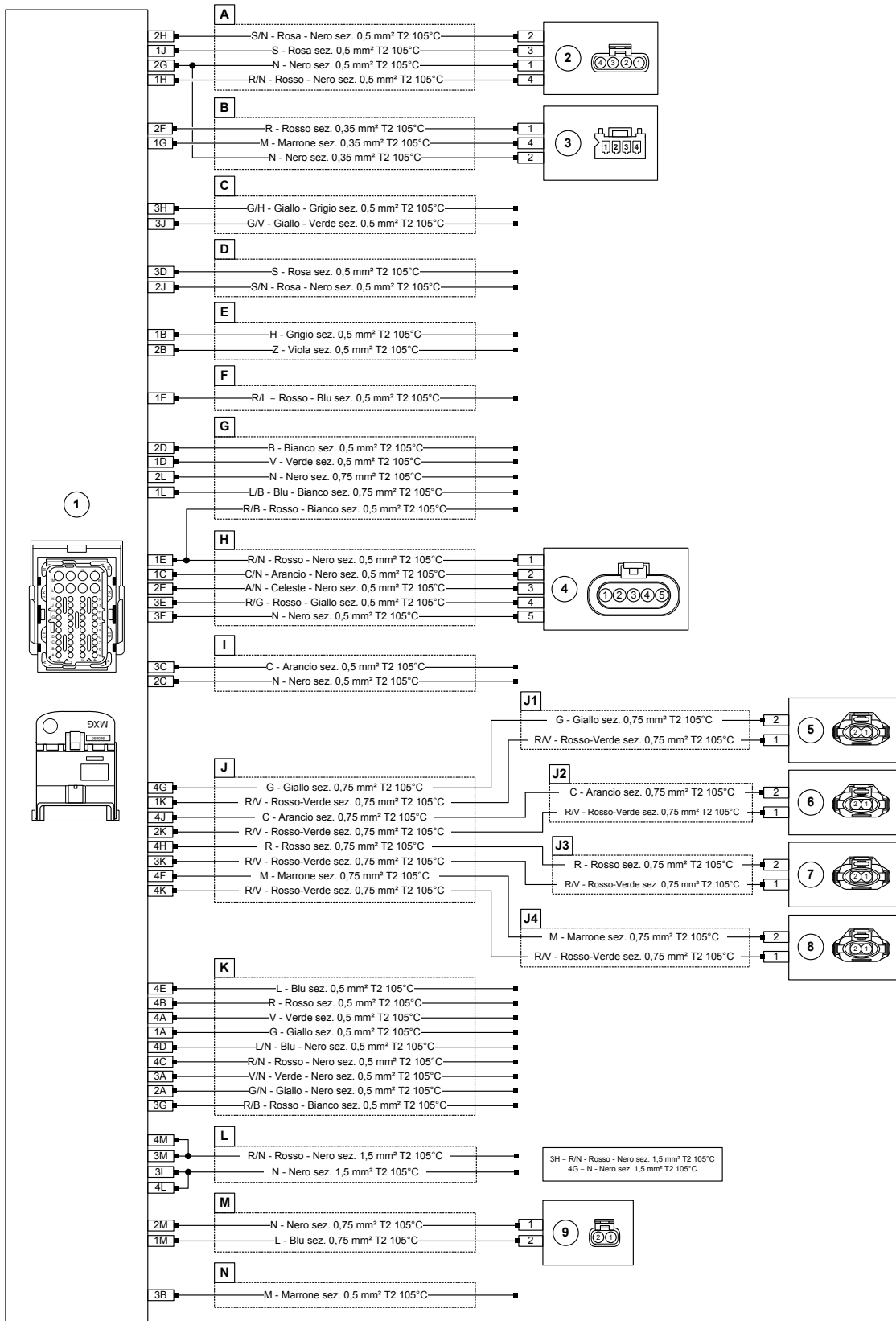

PIN-OUT ECU OMEGAS 4.0 (2-3-4 CYLINDERS)

PIN	Description
1A	Injector B 4 cut-out (INJ side)
1B	Lambda probe emulation
1C	Gas temperature signals
1D	Fuel level
1E	Pressure sensor power supply
1F	P/G/P command switch
1G	RPM signals for switching fuel
1H	Diagnosis power supply
1J	Transmission of diagnosis data
1K	Alim. Iniettore gas n°1
1L	Power supply Gas injector N° 1
1M	Regulator solenoid positive

PIN	Description
2A	Injector B 4 cut-out (ECU side)
2B	Lambda probe input signal
2C	Temperature sensor negative
2D	Fuel level
2E	Gas pressure input signal
2F	Switch positive (5v)
2G	Switch negative
2H	Receipt of diagnosis data
2J	Diagnostics negative
2K	Power supply Gas injector N° 2
2L	Tank solenoid negative
2M	Regulator solenoid negative

PIN	Description
3A	Injector B 3 cut-out (ECU side)
3B	Engine RPM signal
3C	Temperature signal
3D	Temperature negative
3E	MAP signal input
3F	OBD II - K-Line
3G	Ignition (15)
3H	OBD II - CAN-L
3J	OBD II - CAN-H
3K	Gas injector 3 power supply
3L	Battery negative
3M	Battery positive

PIN	Description
4A	Injector B 3 cut-out (INJ side)
4B	Injector B 2 cut-out (INJ side)
4C	Injector B 2 cut-out (ECU side)
4D	Injector B 1 cut-out (ECU side)
4E	Injector B 1 cut-out (INJ side)
4F	Injector G 4 signal
4G	Injector G 1 signal
4H	Injector G 3 signal
4J	Injector G 2 signal
4K	Power supply Gas injector N° 4
4L	Battery negative
4M	Battery positive

Cable code tables Italian / English

- TABELLA SIGLE COLORI CAVI ITALIANO/INGLESE-

SIGLA / CODE	COLORE / COLOR	
A	Celeste	Light Blue
B	Bianco	White
C	Arancio	Orange
G	Giallo	Yellow
H	Grigio	Grey
L	Blu	Blue
M	Marrone	Brown
N	Nero	Black
R	Rosso	Red
S	Rosa	Pink
V	Verde	Green
W	Nocciola	Light Brown
Z	Viola	Violet

LANDIRENZO OMEGAS 4.0 WIRING LAYOUT (2-3-4 CYLINDERS)

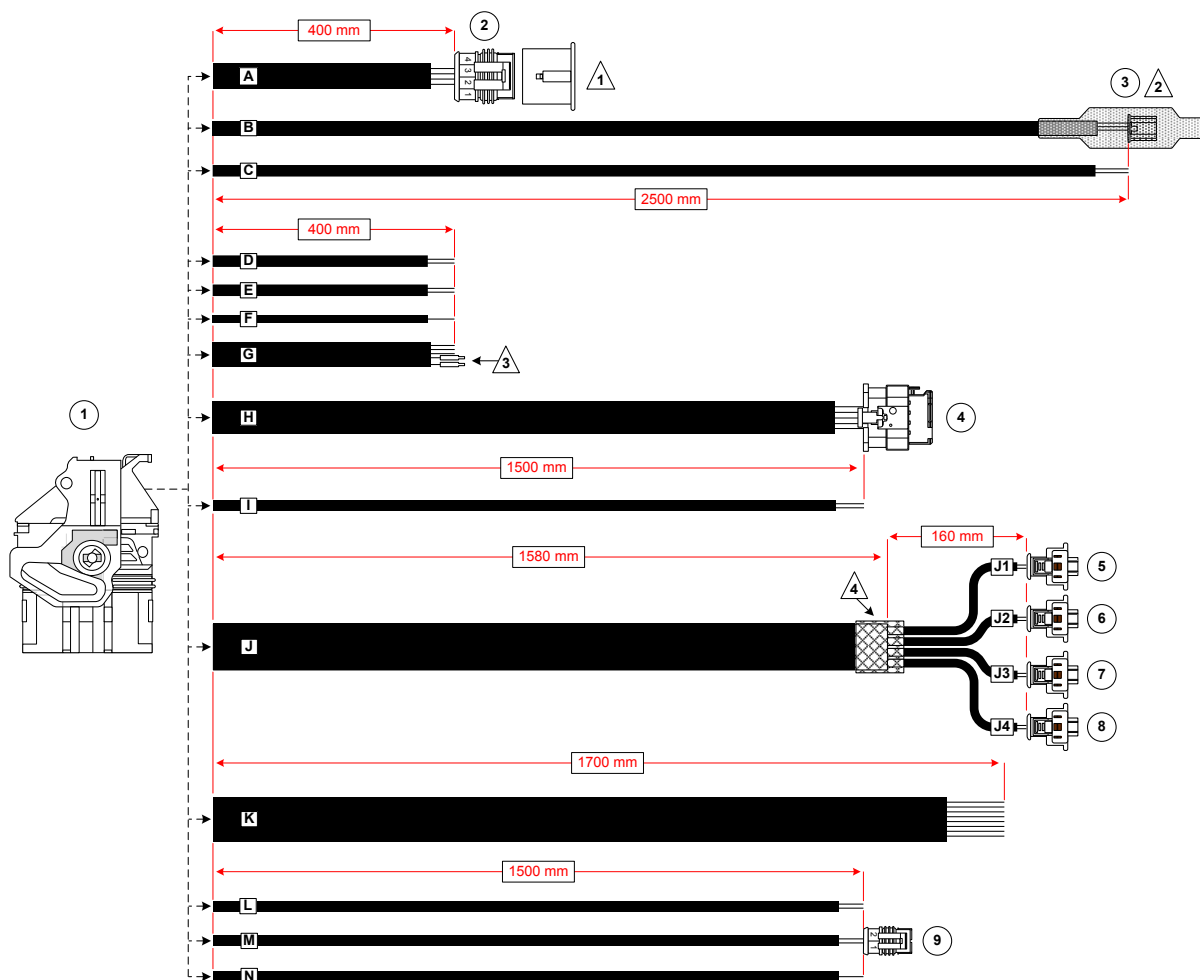

REF.	COMPONENTS
1	N.1 48-way connector code 64320-3311 series CMC MOLEX code AEB 741001026 provided in subcontracting N.1 Cap code 64320-1301 series CMC MOLEX code AEB 741001027 provided in subcontracting N.2 F-Terminal code 64322-1019 series CP0,6 sec. 0,35 mm ² N.29 F-Terminal code 64322-1039 series CP0,6 sec. 0,5 mm ² N.9 F-Terminal code 64322-1029 series CP0,6 sec. 0,75 mm ² N.4 F-Terminal code 64323-1029 series CP1,5 sec. 0,5 mm ² / 1 mm ² N.4 F-Terminal code 64323-1039 series CP1,5 sec. 1 mm ² / 2 mm ²
2	N.1 4-way connector code AEB 741001037 N.4 F-Terminal code 282403-1 series S.SEAL sec. 0,3 mm ² / 0,5 mm ² N.4 Grommet code 281934-4 series S.SEAL - Green - sec. 0,35 mm ² / 0,5 mm ²
3	N.1 4-way connector code PAP-04V-S series PA JST N.4 F-Terminal code SPHD-001T-P.05 JST sec. 0,13 mm ² / 0,35 mm ²
4	N.1 5-way connector code AEB 741001040 provided in subcontracting N.5 F-Terminal code 1452668-1 series MCP sec. 0,5 mm ² / 0,75 mm ² N.5 Grommet code 967067-1 series MQS - Green - sec. 0,5 mm ² / 0,75 mm ²
5 - 6 7 - 8	N.4 2-way connector code AEB 741001070 N.8 F-Terminal code 1703034-1 TYCO sec. 0,5 mm ² / 1 mm ² N.8 Grommet code 828904-1 series JPT TYCO sec. 0,3 mm ² / 1 mm ²
9	N.1 2-way connector code AEB 741001036 N.2 F-Terminal code 282110-1 series S.SEAL sec. 0,75 mm ² / 1,5 mm ² N.2 Grommet code 281934-2 series S.SEAL - Yellow - sec. 0,75 mm ² / 1,5 mm ²

LANDIRENZO EVO OBD ECU (2-3-4 CYLINDERS)

LANDIRENZO EVO OBD is an electronic ECU (2-3-4 cylinder) that manage the supply of gas on vehicles with multipoint injection systems. The ECU uses various signals from the petrol injection ECU (see “Operating Principle“ section) to recalculate the right fuel metering for the vehicle, to manage the switch from petrol to gas and vice versa in the event of running out of gas.

Through to the communication with the OBD protocol, it can reads some parameters from the original petrol ECU to adapt the system in order to compensate the drifts and the aging of the Gas components.

The OBD connection also allows the monitoring of various engine parameters directly from the calibration software and any errors in the engine control system.

It features an auto-diagnostic system and manages changing back to petrol in the event of a fault.

SIGNALS FROM THE ENGINE

- Petrol injection times
- Radiator coolant temperatures
- Intake manifold vacuum readings
- Lambda probe
- Engine speed
- Battery voltage
- OBD

SIGNALS FROM GAS SYSTEM COMPONENTS

- Gas pressure
- Gas temperature
- Fuel level sensor

GOVERNING GAS SYSTEM COMPONENTS

- Fuel switch
- Fuel level indicator
- Regulator solenoid - solenoid(s) tank(s)
- Gas injectors

FUNCTIONS

- Deactivation and emulation of petrol injectors
- External relay control for fuel pump disconnection (it is possible using an EV output)
- Diagnostic
- Separate front EV and rear EV control
- OBD communication (CAN and Line K)
- References to petrol correctors for self-activity
- SW Dedicated Remote Assistance future gas Tools world devices

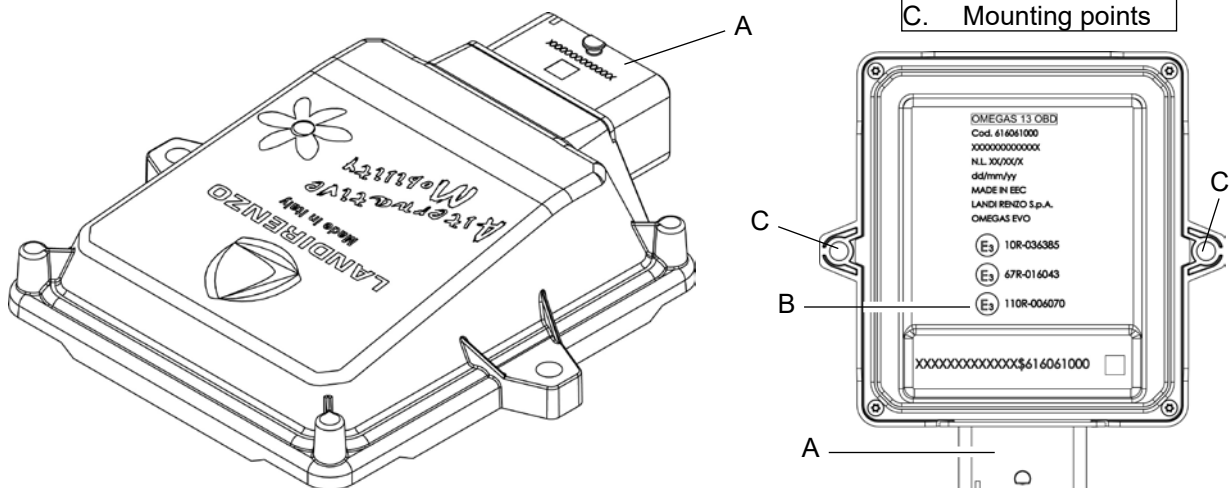

TECHNICAL DATA

GAS TYPE AND NUMBER OF CYLINDERS:	LPG, CNG - 2÷4
CASE	TECHNOPOLYMER
SUPPLY VOLTAGE:	10 ÷ 16 V
MAX CURRENT WITH ACTUATORS OFF:	≤ 0.5 A
STANDBY MAX CURRENT :	≤ 50 µA
DRIVER INJECTORS:	4
SOLENOID VALVES OUTPUT:	2
MAXIMUM CURRENT (FOR SINGLE OUTPUT):	2A*
FLASH MEMORY:	128 kb
PROCESSOR SPEED (pll):	25 MHz
WEIGHT	196 g
DIMENSION:	134x152x36 mm
WORKING TEMPERATURE:	-40°C ÷ 110°C
CLASS IP :	IP54
ECU CONNECTOR:	48 PIN
HOMOLOGATION:	E3 10R-036385 - E3 67R-016043 - E3 110R-006070

* in case of more solenoids, use relay harness kit (e.g. KF 387 AEB) or additional flow relays suited to the current required.

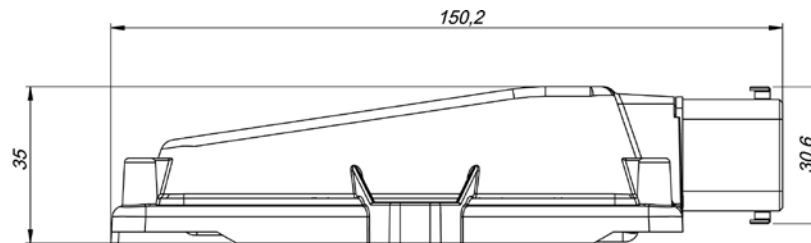

EVO OBD

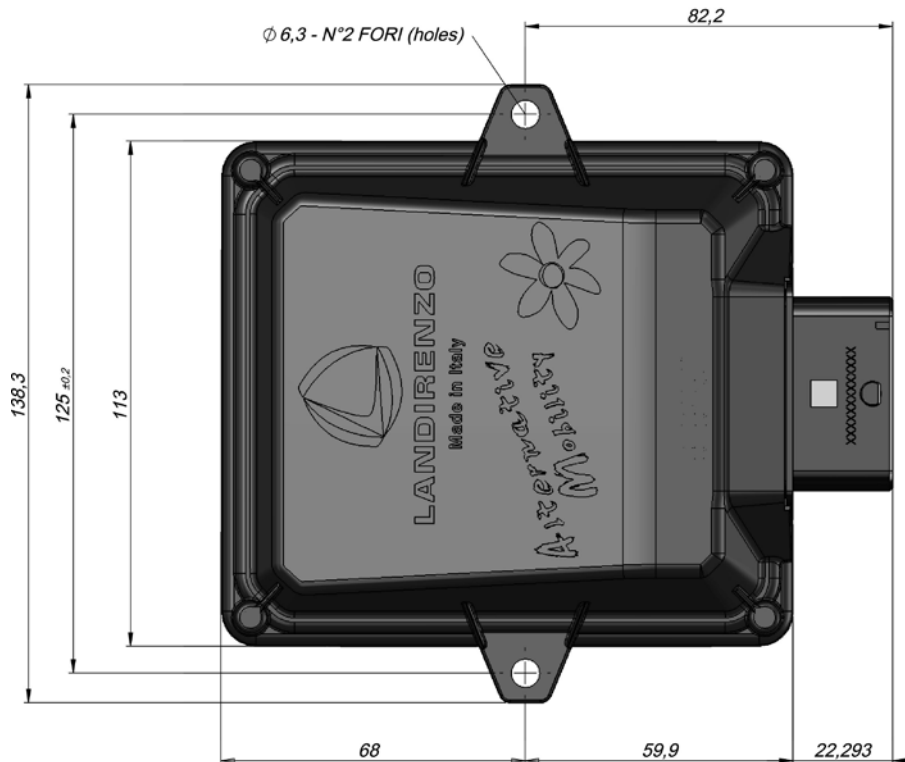

LANDIRENZO EVO OBD WIRING PIN-OUT (2-3-4 CYLINDERS)

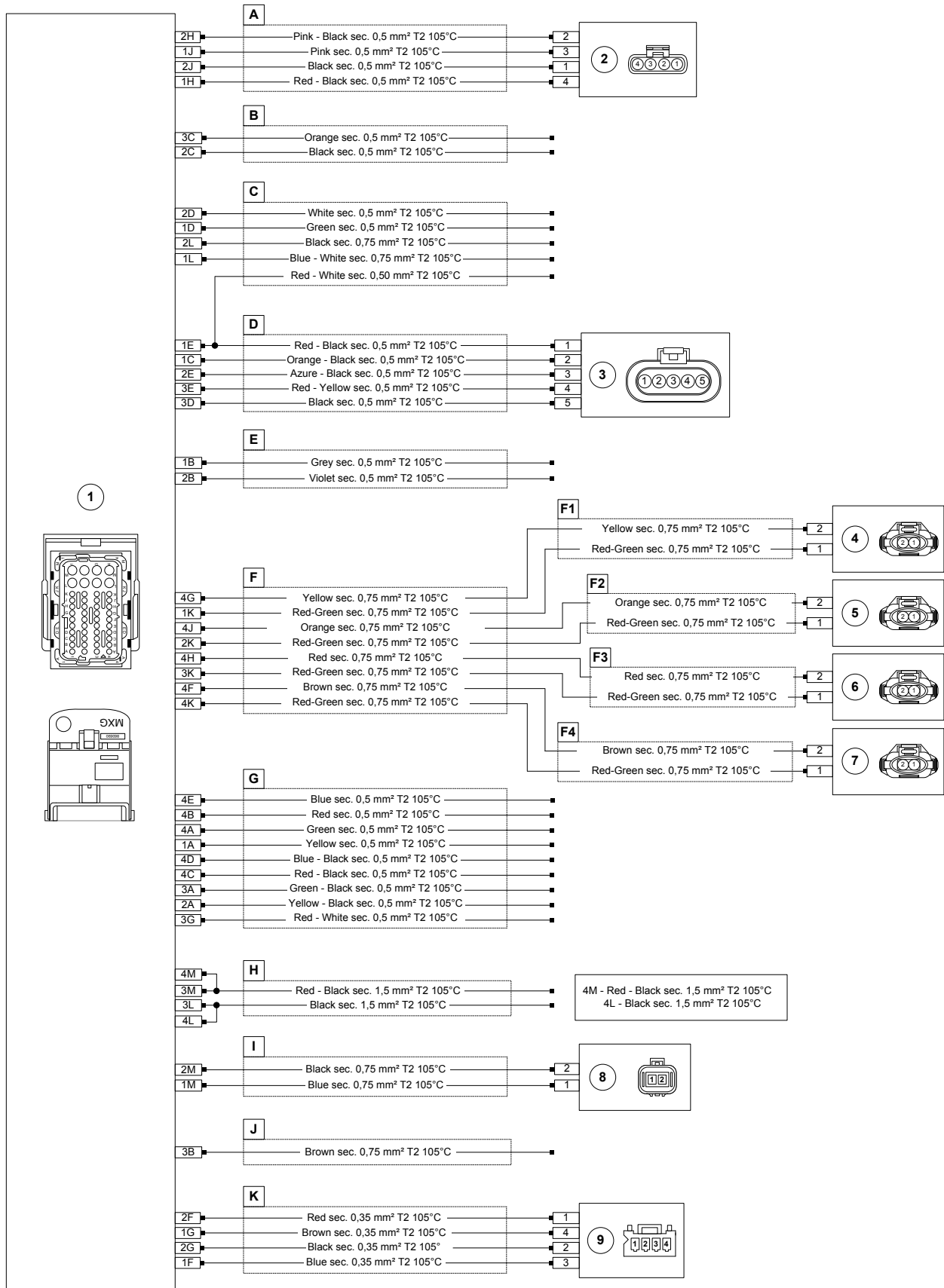

LANDIRENZO EVO OBD PIN-OUT (2-3-4 CYLINDERS)

PIN	Description
1A	Injector B 4 cut-out (INJ side)
1B	Lambda probe emulation
1C	Gas temperature signals
1D	Fuel level
1E	Pressure sensor power supply
1F	P/G/P command switch
1G	RPM signals for switching fuel
1H	Diagnosis power supply
1J	Transmission of diagnosis data
1K	Alim. Iniettore gas n°1
1L	Power supply Gas injector N° 1
1M	Regulator solenoid positive

PIN	Description
2A	Injector B 4 cut-out (ECU side)
2B	Lambda probe input signal
2C	Temperature sensor negative
2D	Fuel level
2E	Gas pressure input signal
2F	Switch positive (5v)
2G	Switch negative
2H	Receipt of diagnosis data
2J	Diagnostics negative
2K	Power supply Gas injector N° 2
2L	Tank solenoid negative
2M	Regulator solenoid negative

PIN	Description
3A	Injector B 3 cut-out (ECU side)
3B	Engine RPM signal
3C	Temperature signal
3D	Temperature negative
3E	MAP signal input
3F	Battery negative
3G	Ignition (15)
3H	-
3J	-
3K	Gas injector 3 power supply
3L	Battery negative
3M	Battery positive

PIN	Description
4A	Injector B 3 cut-out (INJ side)
4B	Injector B 2 cut-out (INJ side)
4C	Injector B 2 cut-out (ECU side)
4D	Injector B 1 cut-out (ECU side)
4E	Injector B 1 cut-out (INJ side)
4F	Injector G 4 signal
4G	Injector G 1 signal
4H	Injector G 3 signal
4J	Injector G 2 signal
4K	Power supply Gas injector N° 4
4L	Battery negative
4M	Battery positive

LANDIRENZO EVO OBD WIRING LAYOUT (2-3-4 CYLINDER)

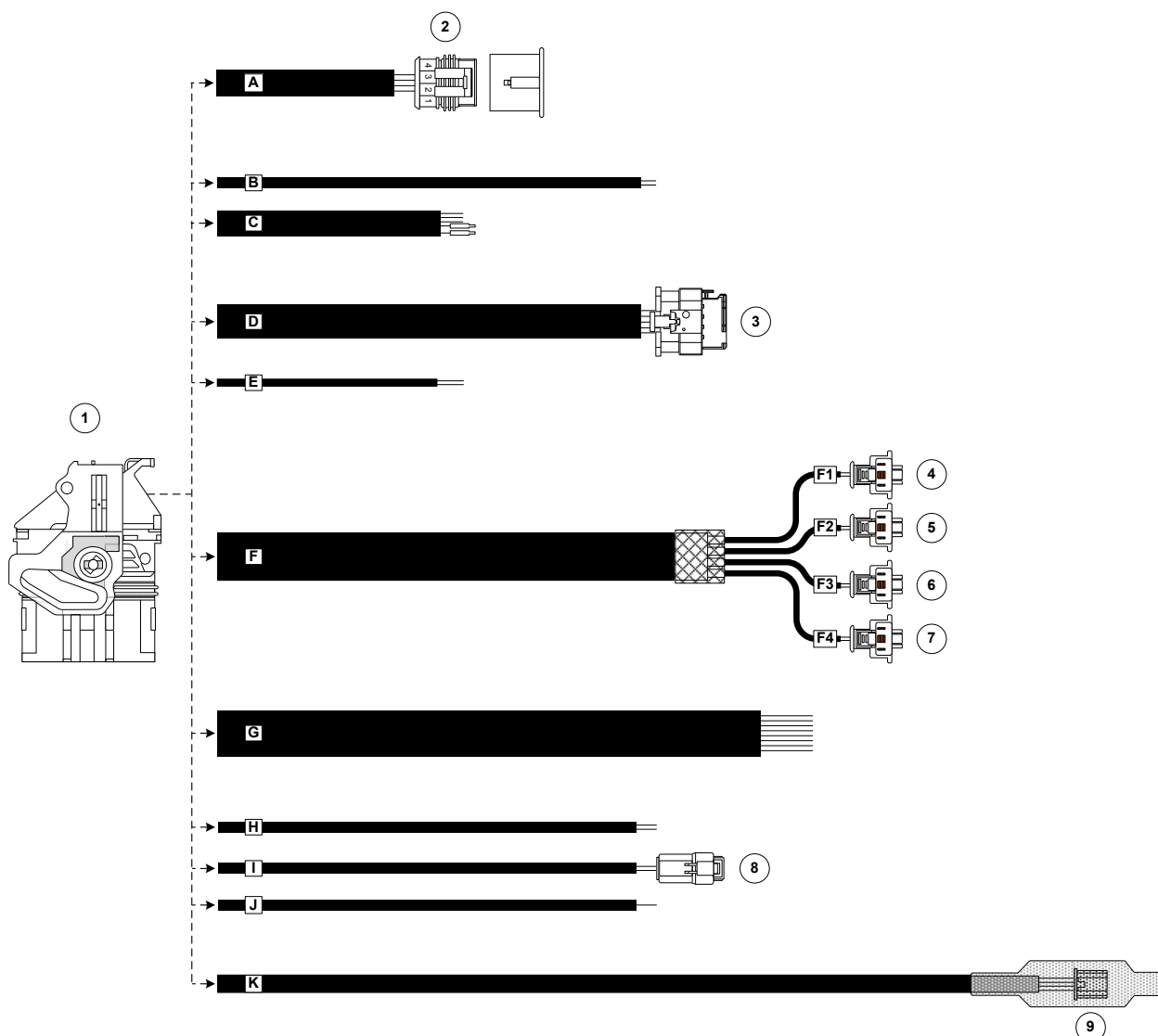

REF.	COMPONENTS
1	N.1 48-way connector code 64320-3311 series CMC MOLEX code AEB 741001026 provided in subcontracting N.1 Cap code 64320-1301 series CMC MOLEX code AEB 741001027 provided in subcontracting N.4 F-Terminal code 64322-1019 series CP0,6 sec. 0,35 mm ² N.28 F-Terminal code 64322-1039 series CP0,6 sec. 0,5 mm ² N.8 F-Terminal code 64322-1029 series CP0,6 sec. 0,75 mm ² N.4 F-Terminal code 64323-1029 series CP1,5 sec. 0,5 mm ² / 1 mm ² N.4 F-Terminal code 64323-1039 series CP1,5 sec. 1 mm ² / 2 mm ² N.1 Plug for open cavity code 0643251010 series CP0,6
2	N.1 4-way connector code AEB 741001037 N.4 F-Terminal code 282403-1 series S.SEAL sec. 0,3 mm ² / 0,5 mm ² N.4 Grommet code 281934-4 series S.SEAL - Green - sec. 0,35 mm ² / 0,5 mm ²
3	N.1 5-way connector code AEB 741001040 provided in subcontracting N.5 F-Terminal code 1452668-1 series MCP sec. 0,5 mm ² / 0,75 mm ² N.8 Grommet code 967067-1 series MQS - Green - sec. 0,5 mm ² / 0,75 mm ²
4 - 5 6 - 7	N.4 2-way connector code AEB 741001070 N.8 F-Terminal code 1703034-1 TYCO sec. 0,5 mm ² / 1 mm ² N.8 Grommet code 828904-1 series JPT TYCO sec. 0,3 mm ² / 1 mm ²
8	N.1 2-way connector code 211PC022S0049 series SICMA FCI. N.2 F-Terminal code 211CC2S1160T series SICMA3 FCI sec. 0,35/0,75 mm ²
9	N.1 4-way connector code PAP-04V-S series PA JST N.4 F-Terminal code SPHD-001T-P.05 JST sec. 0,13 mm ² / 0,35 mm ²

LANDIRENZO EVO L ECU (2-3-4 CYLINDERS)

LANDIRENZO EVO L is an electronic ECU (2-3-4 cylinder) that manage the supply of gas on vehicles with multipoint injection systems. The ECU uses various signals from the petrol injection ECU (see “Operating Principle“ section) to recalculate the right fuel metering for the vehicle, to manage the switch from petrol to gas and vice versa in the event of running out of gas.

It features an auto-diagnostic system and manages changing back to petrol in the event of a fault.

SIGNALS FROM THE ENGINE

- Petrol injection times
- Radiator coolant temperatures
- Intake manifold vacuum readings
- Battery voltage

SIGNALS FROM GAS SYSTEM COMPONENTS

- Gas pressure
- Gas temperature
- Fuel level sensor

GOVERNING GAS SYSTEM COMPONENTS

- Fuel switch
- Fuel level indicator
- Regulator solenoid - solenoid(s) tank(s)
- Gas injectors

FUNCTIONS

- Deactivation and emulation of petrol injectors
- Diagnostic
- Communication with the dedicated software installed on PC
- Remote Assistance SW Tool
- Single output control for front and rear EV.

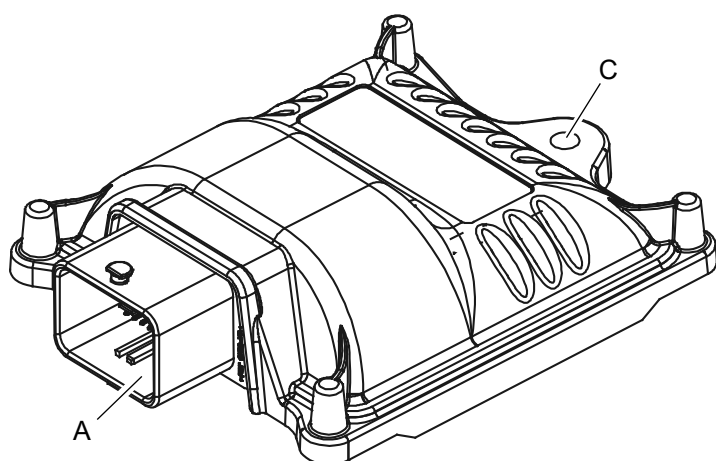

- A. Connector
- B. Homologation
- C. Mounting points

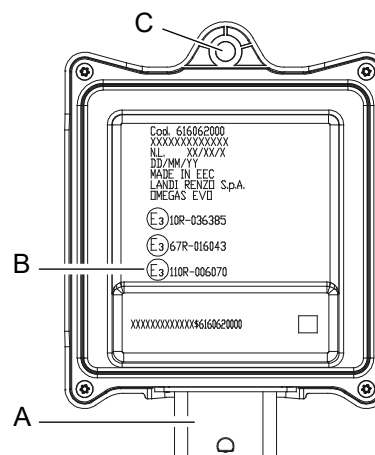

TECNICAL DATA

GAS TYPE AND NUMBER OF CYLINDERS	LPG, CNG - 2÷4
CASE	TECHNOPOLYMER
SUPPLY VOLTAGE	10 ÷ 16 V
MAX CURRENT WITH ACTUATORS OFF	≤ 0.5 A
STANDBY MAX CURRENT:	≤ 50 μA
DRIVER INJECTORS:	4
SOLENOID VALVES OUTPUT:	1
MAXIMUM CURRENT (FOR SINGLE OUTPUT):	2A*
FLASH MEMORY :	128 kb
PROCESSOR SPEED (pll):	25 MHz
WEIGHT:	196 g
DIMENSION:	144x106x35 mm
WORKING TEMPERATURE:	-40°C ÷ 110°C
CLASS IP :	IP6K9K
ECU CONNECTOR:	32 PIN
HOMOLOGATION:	10R-03 6333 - 67R-01 6019 - 110R-00 6039

* in case of more solenoids, use relay harness kit (e.g. KF 387 AEB) or additional flow relays suited to the current required.

EVO L

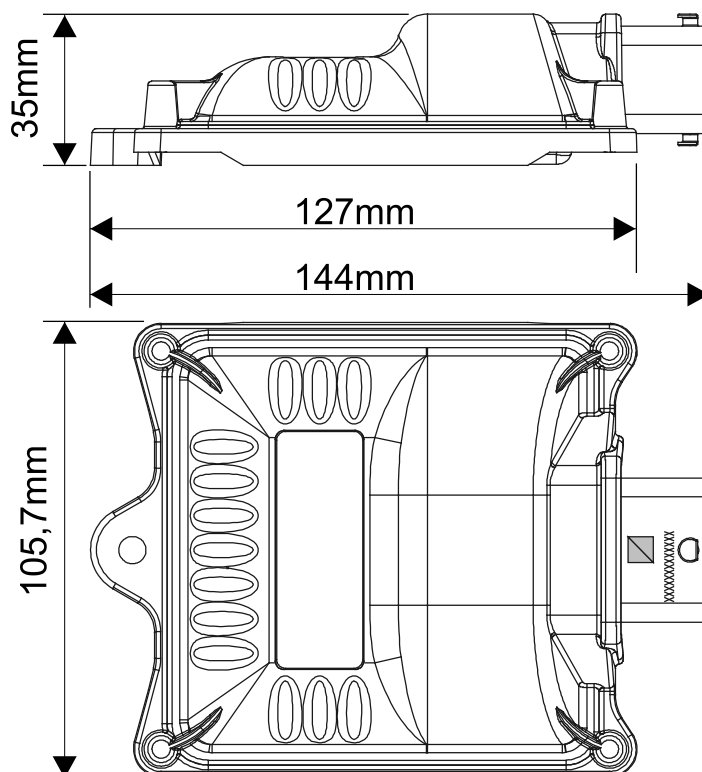

LANDIRENZO EVO L WIRING PIN-OUT (2-3-4 CYLINDERS)

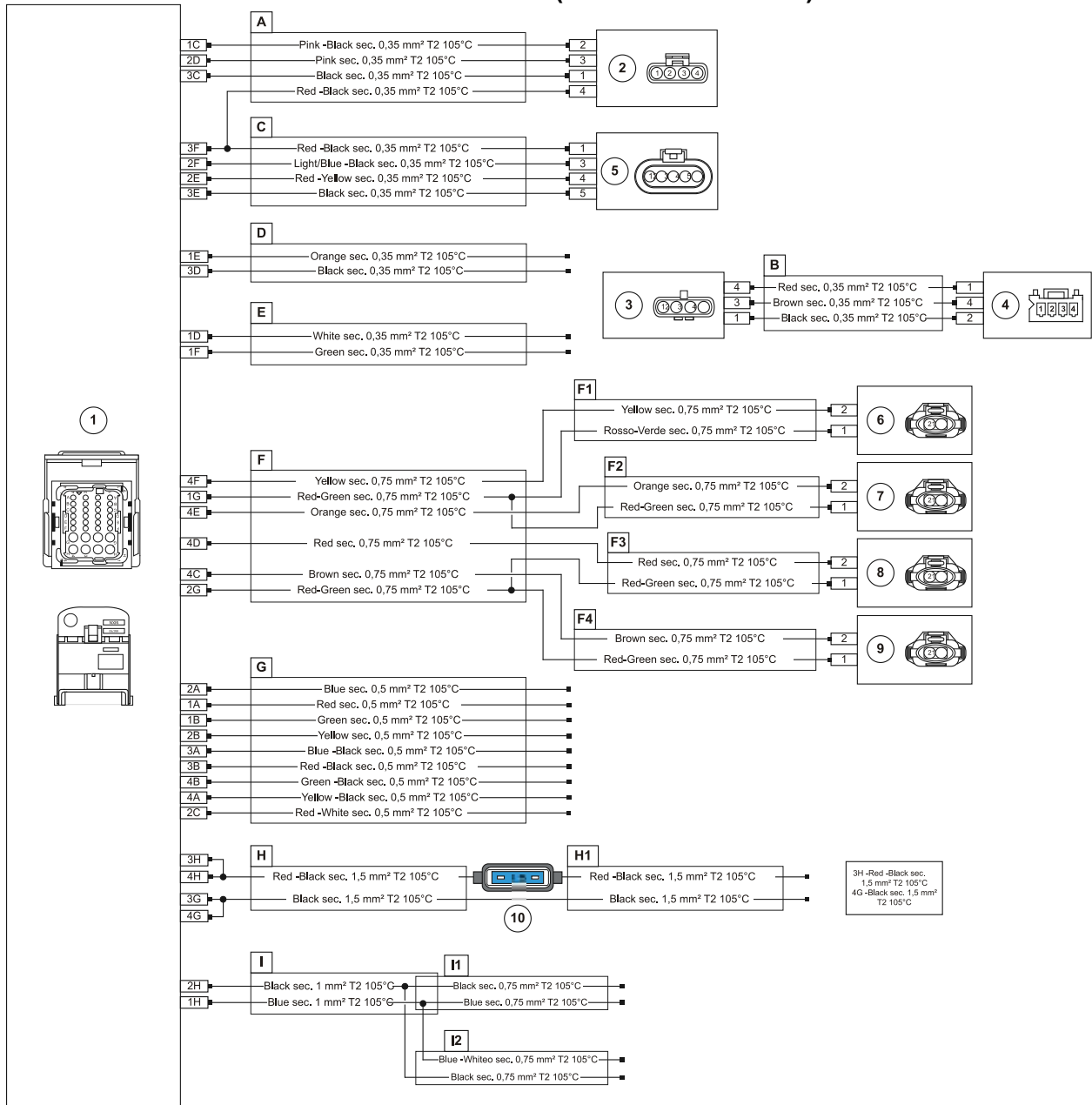

LANDIRENZO EVO L PIN-OUT (2-3-4 CYLINDERS)

PIN	Descrizione	PIN	Descrizione
1A	Petrol injector2	2A	Petrol injector1
1B	Petrol injector3	2B	Petrol injector4
1C	RX	2C	KEY ON
1D	Gas_Tank_Level	2D	TX
1E	Press_Reg_Temp	2E	Map
1F	+5VSense	2F	GAS PRESS
1G	Injector positive1-2	2G	Injector positive3-4
1H	Solenoid valve1	2H	GND solenoid valve1
3A	Petrol ECU injector1	4A	Petrol ECU injector4
3B	Petrol ECU injector2	4B	Petrol ECU injector3
3C	GND	4C	Gas injector4
3D	GND	4D	Gas injector3
3E	GND	4E	Gas injector2
3F	+5V	4F	Gas injector1
3G	GND	4G	GND
3H	Battery	4H	Battery

LANDIRENZO EVO L WIRING LAYOUT (2-3-4 CYLINDERS)

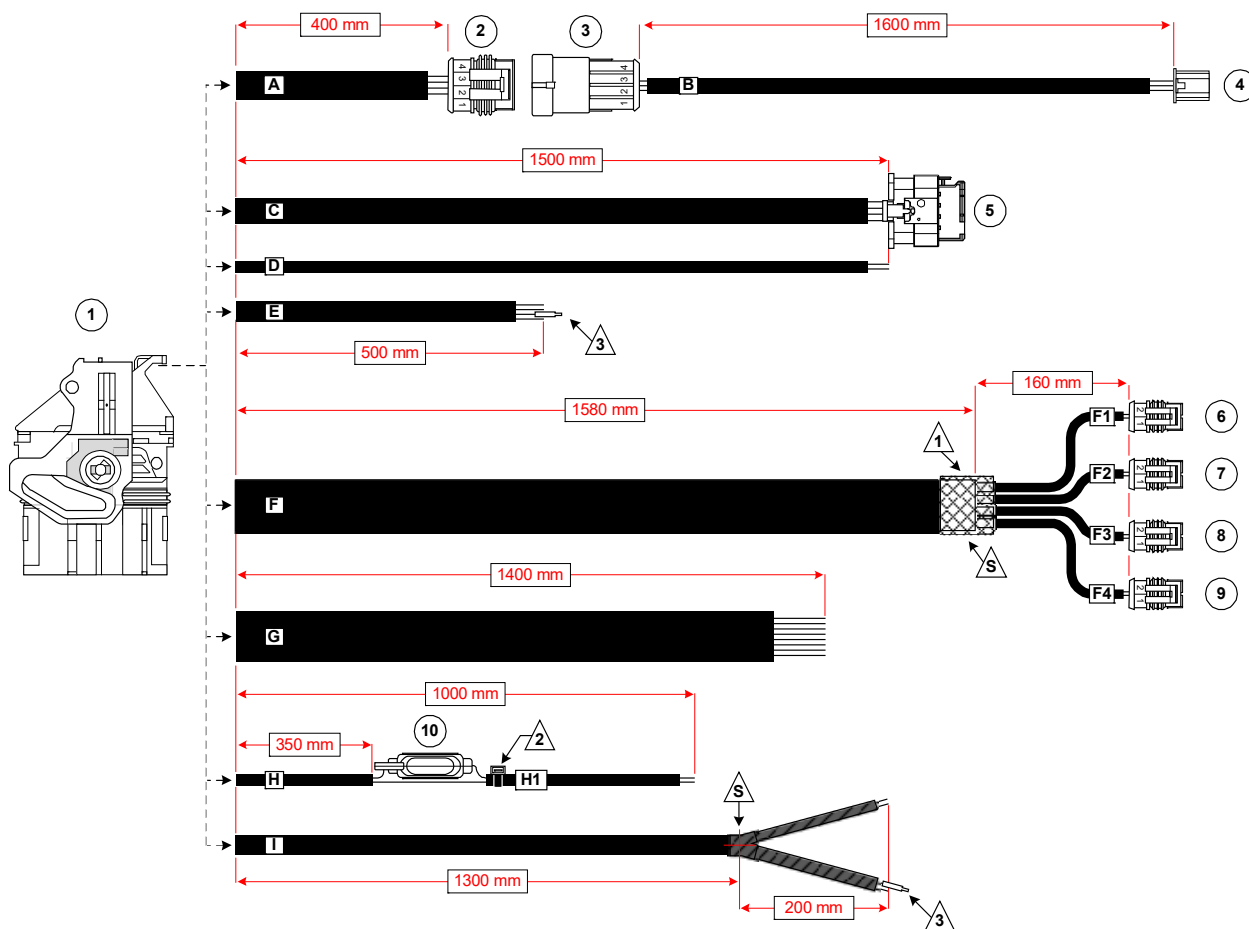

REF.	COMPONENTS
①	<p>N.1 48-way connector code 64320-3311 series CMC MOLEX code AEB 741001026 provided in subcontracting</p> <p>N.1 Cap code 64320-1301 series CMC MOLEX code AEB 741001027 provided in subcontracting</p> <p>N.2 Terminal F. codice 64322-1019 series CP0,6 sez. 0,35 mm².</p> <p>N.29 Terminal F. codice 64322-1039 series CP0,6 sez. 0,5 mm².</p> <p>N.9 Terminal F. codice 64322-1029 series CP0,6 sez. 0,75 mm².</p> <p>N.4 Terminal F. codice 64323-1029 series CP1,5 sez. 0,5 mm² / 1 mm².</p> <p>N.4 Terminal F. codice 64323-1039 series CP1,5 sez. 1 mm² / 2 mm².</p>
②	<p>N.1 4-way connector code AEB 741001037.</p> <p>N.4 Terminal F. code 282403-1 series S.SEAL sec. 0,3 mm² / 0,5 mm².</p> <p>N.4 Grommet code 281934-4 series S.SEAL - Green - sec. 0,35 mm² / 0,5 mm².</p>
③	<p>N.1 4-way connector code PAP-04V-S series PA JST</p> <p>N.3 Terminal M. code 282404-1 series S.SEAL sec. 0,3 mm² / 0,5 mm².</p> <p>N.3 Grommet code 281934-4 series S.SEAL - Green - sec. 0,35 mm² / 0,5 mm².</p> <p>N.1 Cavity cap code 282081-1 series S.SEAL - Red</p>
④	<p>N.1 4-way connector code PAP-04V-S series PA JST.</p> <p>N.3 Terminal F. code SPHD-001T-P.05 JST sec. 0,13 mm² / 0,35 mm².</p>
⑤	<p>N.1 5-way connector code AEB 741001040 provided in subcontracting</p> <p>N.4 Terminal F. code 1452668-1 series MCP sec. 0,5 mm² / 0,75 mm².</p> <p>N.4 Grommet code 967067-1 series MQS - Green - sec. 0,5 mm² / 0,75 mm².</p> <p>N.1 Cavity cap code 967056-1 series MQS - Blu.</p>
⑥ ⑦ ⑧ ⑨	<p>N.4 2-way connector code AEB 741001036.</p> <p>N.8 Terminal F. code 282110-1 series S.SEAL sec. 0,75 mm² / 1,5 mm².</p> <p>N.8 Grommet code 281934-2 series S.SEAL - Yellow - sec. 0,75 mm² / 1,5 mm².</p>
⑩	<p>N.1 Fuse holder IP67 sec.2,5 mm² code AEB 203940000 provided in subcontracting</p> <p>N.1 Fuse code ELMAC EATU15A. Alternatively code 07.00340 15A UNIVAL MTA</p>

LANDIRENZO OMEGAS 3.0 (5-6-8 CYLINDERS) LANDIRENZO EVO OBD (5-6 CYLINDERS)

LANDIRENZO OMEGAS 3.0 and LANDIRENZO EVO OBD are electronic ECU (5-6-8 cylinder) that manage the supply of gas on vehicles with multipoint injection systems. The ECU uses various signals from the petrol injection ECU (see "Operating Principle" section) to recalculate the right fuel metering for the vehicle, to manage the switch from petrol to gas and vice versa in the event of running out of gas. It features an auto-diagnostic system and manages changing back to petrol in the event of a fault.

SIGNALS FROM THE ENGINE

- Petrol injection times
- Radiator coolant temperatures
- Intake manifold vacuum readings
- Lambda probe
- RPM
- Battery voltage
- OBD (only on LANDIRENZO OMEGAS system)

SIGNALS FROM GAS SYSTEM COMPONENTS

- Gas pressure
- Gas temperature
- Fuel level sensor

GOVERNING GAS SYSTEM COMPONENTS

- Fuel switch
- Fuel level indicator
- Regulator solenoid - solenoid(s) tank(s)
- Gas injectors

FUNCTIONS

- Petrol injector deactivation
- Diagnostics
- Communication with dedicated software installed on PC
- Communication with OBD (only on LANDIRENZO OMEGAS system)
- Lambda probe emulation (optional, only if necessary)

OMEGAS and EVO

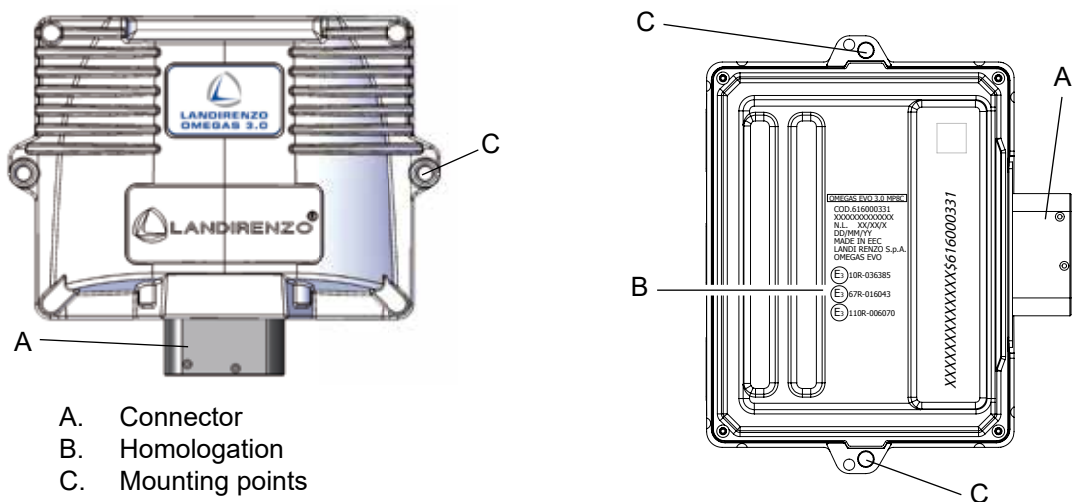

TECHNICAL DATA

GAS TYPE AND NUMBER OF CYLINDERS	LPG, CNG - 5÷8
CASE	METALLIC
SUPPLY VOLTAGE:	10 ÷ 16 V
MAX CURRENT WITH ACTUATORS OFF :	≤ 0.5 A
STANDBY MAX CURRENT :	≤ 50 µa
DRIVER INJECTORS:	8
SOLENOID VALVES OUTPUT:	2
MAXIMUM CURRENT (FOR SINGLE OUTPUT):	2A*
FLASH MEMORY :	128 kb
PROCESSOR SPEED (pll):	50 MHz
WEIGHT :	400 g
DIMENSION:	196x163x43 mm
WORKING TEMPERATURE:	-40°C ÷ 120°C
PCLASS IP :	IP6K9K
ECU CONNECTOR:	60 PIN
HOMOLOGATION:	E3 67R-016043 - E3 110R-006070 - E3 10R-036385

* in case of multiple solenoid valves on the cylinders, use the RELAY KIT for E.V. REAR (ex. KF378 AEB or additional relays of adequate capacity for the current required).

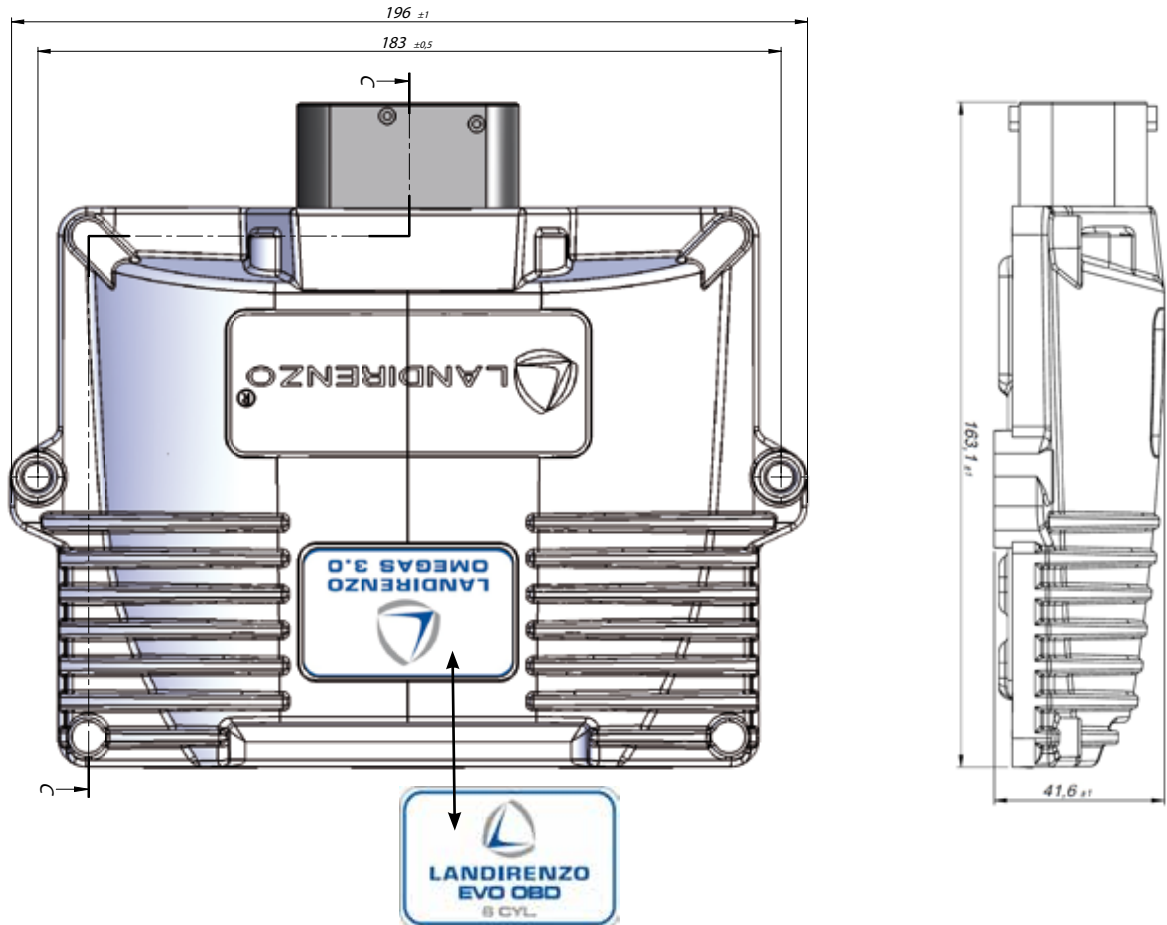

ECU OMEGAS 3.0 (5-6-8 CYL.) AND EVO OBD (5-6 CYL.) PINOUT

PIN-OUT OMEGAS 3.0 - EVO OBD - 6 CYL							
PIN	DESCRIPTION	PIN	DESCRIPTION	PIN	DESCRIPTION	PIN	DESCRIPTION
60	BATTERY	45	BATTERY RELAYS	30	GND BATTERY	15	GND BATTERY
59	KEY ON	44	MAIN RELAY	29	FUEL PUMP CNTRL	14	PETROL RELAY
58	ECU SIDE - INJ A	43	INJ SIDE - INJ A	28	ECU SIDE - INJ E	13	INJ SIDE - INJ E
57	ECU SIDE - INJ D	42	INJ SIDE - INJ D	27	ECU SIDE - INJ B	12	INJ SIDE - INJ B
56	ECU SIDE - INJ F	41	INJ SIDE - INJ F	26	-	11	-
55	ECU SIDE - INJ C	40	INJ SIDE -INJ C	25	-	10	-
54	RPM	39	RX SERIAL	24	+ 5V SENSOR	9	SERIAL DATA COS
53	SERIALE POWER SUPPLY	38	TX SERIAL	23	+ 5V COS	8	SERIAL BOTTOM COS
52	CAN H	37	GND	22	GND COS	7	GAS RESSURE
51	CAN L	36	K-LINE	21	MAP	6	GAS TEMPERATURE
50	LAMBDA 2	35	OUT LAMBDA 2	20	LAMBDA 1	5	OUT LAMBDA 1
49	LEVEL SENSOR	34	SENSOR POWER SUPPLY	19	GND SENSOR	4	REDUCER TEMP.
48	OUT INJ H	33	OUT INJ D	18	OUT INJ A	3	OUT INJ B
47	OUT INJ F	32	OUT INJ E	17	OUT INJ C	2	OUT INJ G
46	EV GND	31	EV2	16	EV1	1	EV GND

PIN-OUT OMEGAS 3.0 - 8 CYL							
PIN	DESCRIPTION	PIN	DESCRIPTION	PIN	DESCRIPTION	PIN	DESCRIPTION
60	BATTERY	45	BATTERY RELAYS	30	GND BATTERY	15	GND BATTERY
59	KEY ON	44	MAIN RELAY	29	FUEL PUMP CNTRL	14	PETROL RELAY
58	ECU SIDE - INJ A	43	INJ SIDE - INJ A	28	ECU SIDE - INJ E	13	INJ SIDE - INJ E
57	ECU SIDE - INJ D	42	INJ SIDE - INJ D	27	ECU SIDE - INJ B	12	INJ SIDE - INJ B
56	ECU SIDE - INJ F	41	INJ SIDE - INJ F	26	ECU SIDE - ING H	11	INJ SIDE - INJ D
55	ECU SIDE - INJ C	40	INJ SIDE -INJ C	25	ECU SIDE - INJ D	10	INJ SIDE - INJ D
54	RPM	39	RX SERIAL	24	+ 5V SENSOR	9	SERIAL DATA COS
53	SERIAL POWER SUPPLY	38	TX SERIAL	23	+ 5V COS	8	SERIAL BOTTOM COS
52	CAN H	37	GND	22	GND COS	7	GAS RESSURE
51	CAN L	36	K-LINE	21	MAP	6	GAS TEMPERATURE
50	LAMBDA 2	35	OUT LAMBDA 2	20	LAMBDA 1	5	OUT LAMBDA 1
49	LEVEL SENSOR	34	SENSOR POWER SUPPLY	19	GND SENSOR	4	REDUCER TEMP.
48	OUT INJ H	33	OUT INJ D	18	OUT INJ A	3	OUT INJ B
47	OUT INJ F	32	OUT INJ E	17	OUT INJ C	2	OUT INJ G
46	EV GND	31	EV2	16	EV1	1	EV GND

ECU OMEGAS 3.0 (5-6-8 CYL.) WIRING LAYOUT

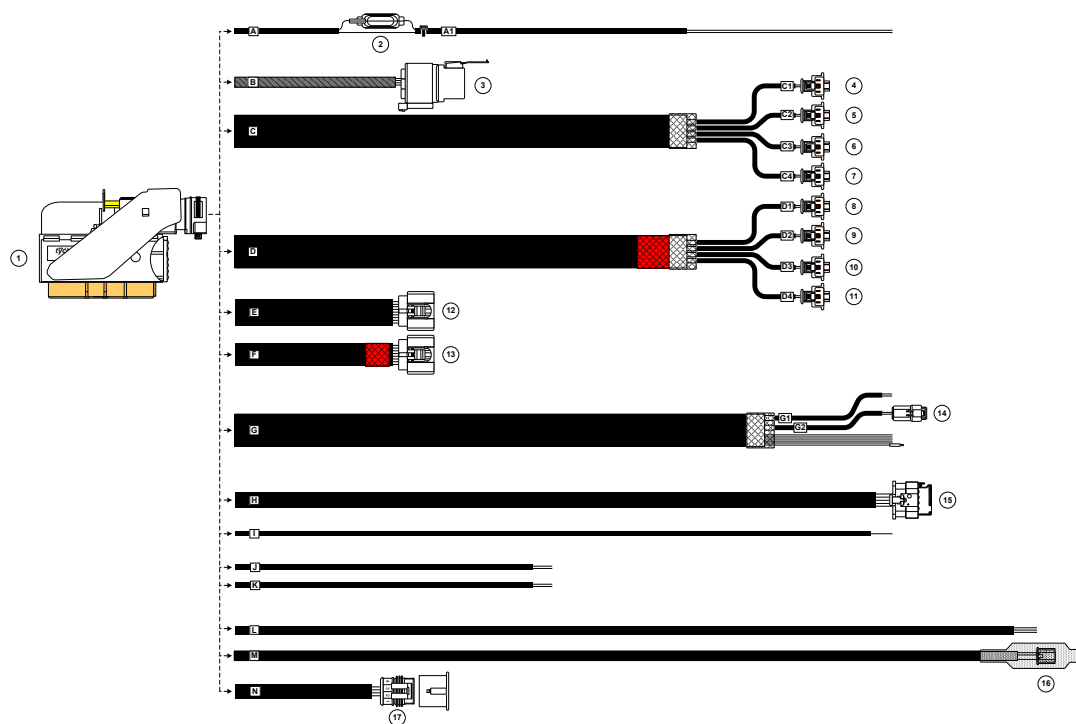

REF.	COMPONENTS
1	N.1 60-way connector code 1-284742-1 + cap + lever + Secondary Lock series MQS code AEB 741001028 N.3 F-Terminal code 968220-1 series MQS 0.5 Clean Body sec. 0,2 mm ² / 0,35 mm ² N.31 F-Terminal code 968221-1 series MQS 0.5 Clean Body sec. 0,5 mm ² / 0,75 mm ² N.8 F-Terminal code 1452158-1 series MQS 1.5 Clean Body sec. 0,35 mm ² / 0,5 mm ² N.16 F-Terminal code 1241608-1 series MQS 1.5 Clean Body sec. 0,75 mm ² / 1,5 mm ² N.1 Plug for open cavity code 284583-1 series MQS 0.5
2	N.1 Fuse holder IP67 sec. 2,5 mm ² code AEB 2039400000 N.1 Blade fuse ELMAC EATU20A. Alternatively code 07.00350 20A UNIVAL MTA
3	N.1 5-way connector code 60430141 FCI code AEB 741001081 N.2 F-Terminal code 60040031 series DCS-1 6,3 sec. 0,5 mm ² / 1 mm ² N.2 Grommet code 60992607 series DCS-1 - Green -sec. 0,5 mm ² / 1 mm ² N.2 F-Terminal code 60040041 series DCS-1 6,3 sec. 1 mm ² / 2,5 mm ² N.2 Grommet code 60992604 series DCS-1 -Giallo -sec. 1 mm ² / 2,5 mm ² N.1 Relay code 1-1414552-0 series Mini ISO Tyco N.1 Plug for open cavity code 60992602 series DCS-1 -Red
4 - 5 6 - 7 8 - 9 10 - 11	N.8 2-way connector code AEB 741001070 N.16 F-Terminal code 1703034-1 TYCO sec. 0,5 mm ² / 1 mm ² N.16 Grommet code 828904-1 series JPT TYCO sec. 0,3 mm ² / 1 mm ²
12 - 13	N.2 10-way connector code AEB 741001045. N.17 F-Terminal code 171662-1 series ECONOSEAL TYCO sec. 0,5 mm ² / 1 mm ² N.17 Grommet code 347874-1 series ECONOSEAL TYCO - Green -sec. 1 mm ² N.2 Secondary Lock code AEB 741001046. N.3 Plug for open cavity code 172748-2 series ECONOSEAL TYCO
14	N.1 2-way connector code 211PC022S0049 series SICMA FCI N.2 F-Terminal code 211CC2S1160T series SICMA3 FCI sec. 0,35 mm ² / 0,75 mm ²
15	N.1 5-way connector code AEB 741001040. N.5 F-Terminal code 1452668-1 series MCP sec. 0,5 mm ² / 0,75 mm ² N.5 Grommet code 967067-1 series MQS - Green -sec. 0,5 mm ² / 0,75 mm ²
16	N.1 4-way connector code PAP-04V-S series PA JST. N.4 F-Terminal code SPHD-001T-P.05 JST sec. 0,13 mm ² / 0,35 mm ²
17	N.1 4-way connector code AEB 741001037. N.4 F-Terminal code 282403-1 series S.SEAL sec. 0,3 mm ² / 0,5 mm ² N.4 Grommet code 281934-4 series S.SEAL - Green -sec. 0,35 mm ² / 0,5 mm ²

ECU EVO OBD (5-6 CYL.) WIRING PINOUT

The wiring of the EVO OBD 5-6 cylinder version does not have cables and connectors direct to the 7-8 injectors and the corresponding cables for excluding petrol injectors

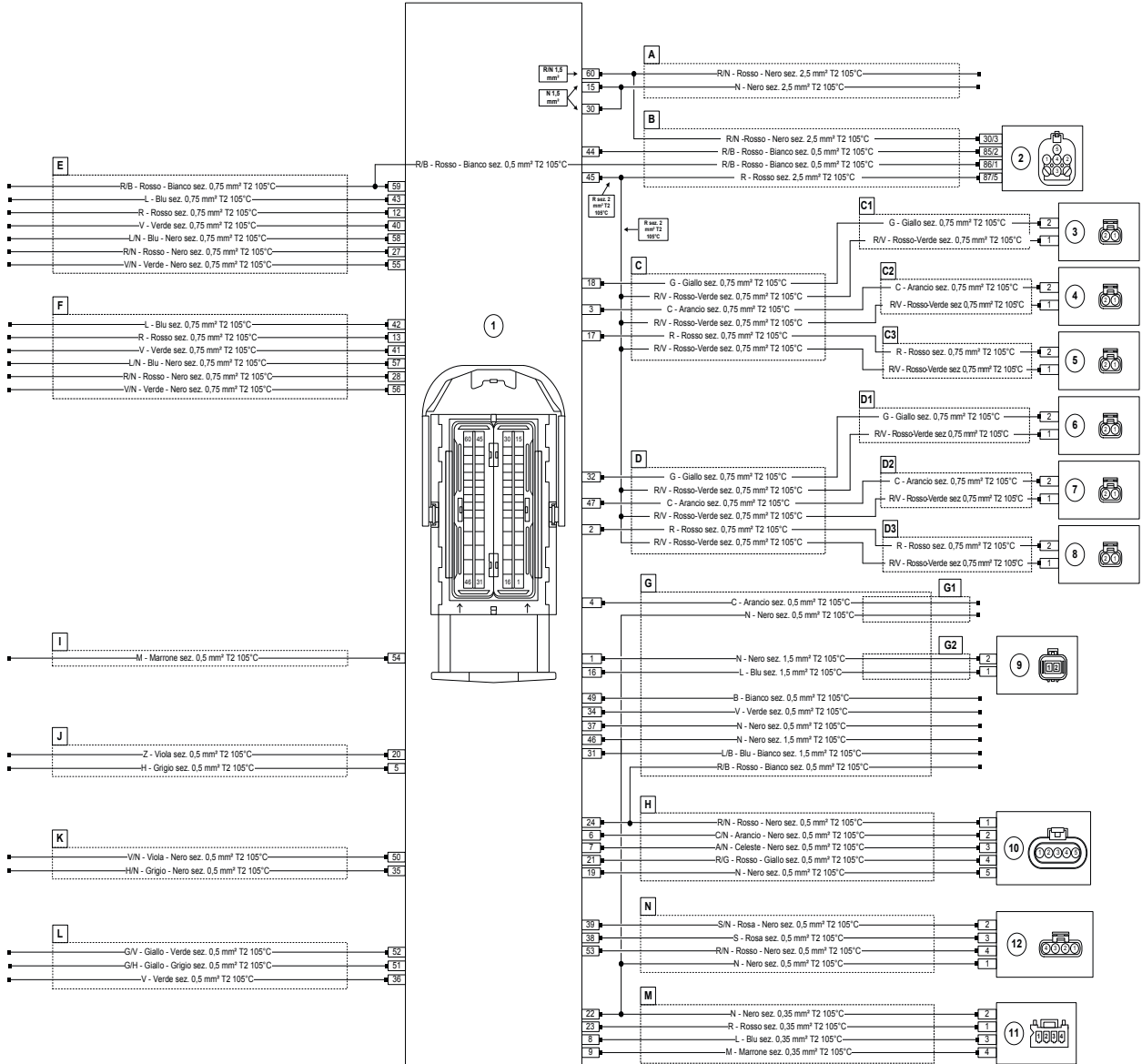

- TABELLA SIGLE COLORI CAVI ITALIANO/INGLESE -

SIGLA / CODE	COLORE / COLOR	
A	Celeste	Light Blue
B	Bianco	White
C	Arancio	Orange
G	Giallo	Yellow
H	Grigio	Grey
L	Blu	Blue
M	Marrone	Brown
N	Nero	Black
R	Rosso	Red
S	Rosa	Pink
V	Verde	Green
W	Nocciola	Light Brown
Z	Viola	Violet

ECU EVO OBD (5-6 CYL.) WIRING LAYOUT

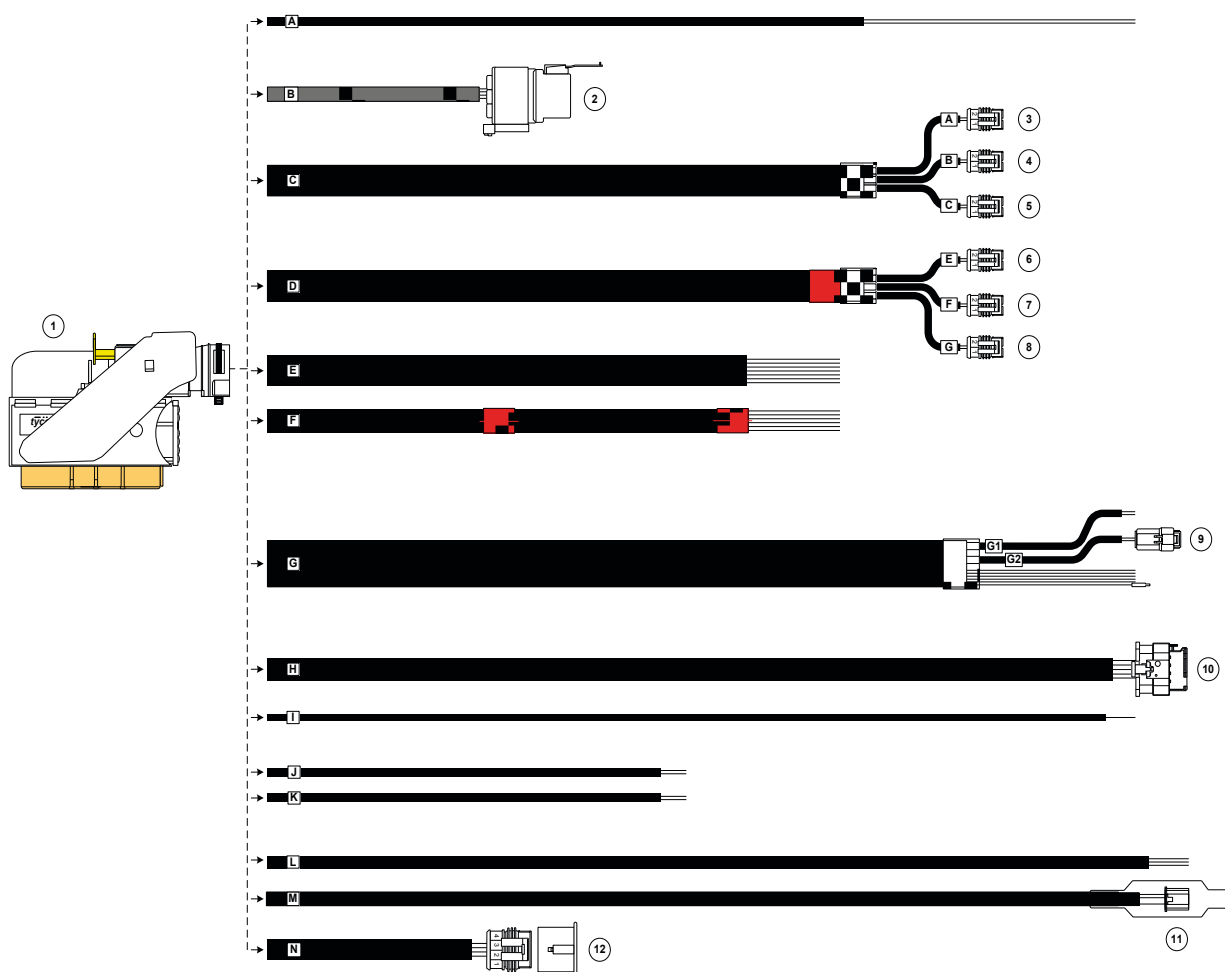

REF.	COMPONENTS
1	N.1 60-way connector code 1-284742-1 + cap + lever + Secondary Lock series MQS code AEB 741001028 N.3 F-Terminal code 968220-1 series MQS 0.5 Clean Body sec. 0,2 mm ² / 0,35 mm ² N.27 F-Terminal code 968221-1 series MQS 0.5 Clean Body sec. 0,5 mm ² / 0,75 mm ² N.8 F-Terminal code 1452158-1 series MQS 1.5 Clean Body sec. 0,35 mm ² / 0,5 mm ² N.14 F-Terminal code 1241608-1 series MQS 1.5 Clean Body sec. 0,75 mm ² / 1,5 mm ² N.6 Plug for open cavity code 284583-1 series MQS 0.5 N.2 Plug for open cavity code 1670108-1 series MQS 1.5
2	N.1 5-way connector code 60430141 FCI code AEB 741001081 N.2 F-Terminal code 60040031 series DCS-1 6,3 sec. 0,5 mm ² / 1 mm ² N.2 Grommet code 60992607 series DCS-1 - Green -sec. 0,5 mm ² / 1 mm ² N.2 F-Terminal code 60040041 series DCS-1 6,3 sec. 1 mm ² / 2,5 mm ² N.2 Grommet code 60992604 series DCS-1 -Giallo -sec. 1 mm ² / 2,5 mm ² N.1 Relay code 1-1414552-0 series Mini ISO Tyco N.1 Plug for open cavity code 60992602 series DCS-1 -Red
3 - 4 5 - 6 7 - 8	N.6 2-way connector code AEB 741001036 N.12 F-Terminal code 282110-1 TYCO sec. 0,75 mm ² / 1,5 mm ² N.12 Grommet code 281934-2 TYCO - yellow - sec. 0,75 mm ² / 1,5 mm ²
9	N.1 2-way connector code 211PC022S0049 series SICMA FCI N.2 F-Terminal code 211CC2S1160T series SICMA3 FCI sec. 0,35 mm ² / 0,75 mm ²
10	N.1 5-way connector code AEB 741001040. N.5 F-Terminal code 1452668-1 series MCP sec. 0,5 mm ² / 0,75 mm ² N.5 Grommet code 967067-1 series MQS - Green -sec. 0,5 mm ² / 0,75 mm ²
11	N.1 4-way connector code PAP-04V-S series PA JST. N.4 F-Terminal code SPHD-001T-P.05 JST sec. 0,13 mm ² / 0,35 mm ²
12	N.1 4-way connector code AEB 741001037. N.4 F-Terminal code 282403-1 series S.SEAL sec. 0,3 mm ² / 0,5 mm ² N.4 Grommet code 281934-4 series S.SEAL - Green -sec. 0,35 mm ² / 0,5 mm ²

MULTIFUNCTION SWITCH

The fuel switch allows the the fuel supply to be changed from petrol to gas and vice versa. The switch also has a fuel level indicator and a beeper that makes different sounds to indicate that the gas tank is empty or that there is a fault with the gas system.

FUNCTIONS

When the engine is started, a yellow led "C" lights up and the green led "B" blinks. This means that the system is waiting to automatically change over to running on gas. This is only a temporary stage while the engine reaches the parameters set in the gas ECU before changing fuel.

Once these parameters have been reached, the green led "B" stays lit, the yellow led "C" goes out and the led display "D" shows the amount of gas in the tank. These lights also mean that the gas system is operating as it should.

Green led "B" blinking slowly (while the buzzer* is sounding slowly and intermittently) indicates that the system is not working properly on gas (diagnosis);

Green led "B" lit (while the "C" led is lit and the buzzer* is sounding rapidly and intermittently) indicates that the system is switching back to petrol as the tank has run out of gas.

*To stop the buzzer, press button "A", (the green led "B" goes out and the yellow led "C" comes on). The vehicle is now running on petrol.

OTHER FEATURES

- LED adjustable light intensity using the button or with PC software;
- 4 levels of sound intensity of the buzzer, adjustable with PC software.

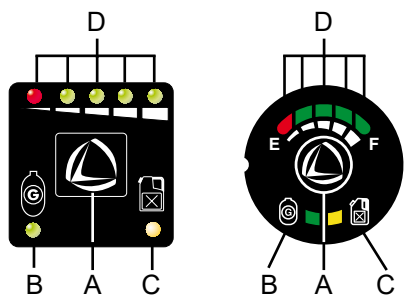

- A. Petrol/gas/petrol change-over button.
- B. Green LED - running on gas.
- C. Yellow LED - running on petrol.
- D. LED display - indicates the amount of gas (split into quarters) in the tank; the red LED is the reserve light.

The switches can also be supplied with LED colors other than those described in this paragraph.

AUTO-DIAGNOSIS

LANDIRENZO OMEGAS and LANDIRENZO EVO systems feature an auto-diagnosis system with which the green led "B" that indicates the engine is running in gas, is also used to indicate faults or that the system is receiving erroneous data from components.

Should one of these faults occur, the green led begins blinking slowly while the engine is running on gas.

If the fault is such that it might prevent the engine from working properly affect, the ECU will automatically change to running the engine on petrol.

In this case, the yellow led will come on and the green one will flash and the switch will beep.

*To stop the buzzer, press button "A"

TANK

Tanks must be positioned at the rear of vehicles and be firmly mounted with specific fittings. There are certain legal obligations that must be complied with:

- **the strength of the fittings used to mount the tank must meet legal requirements;**
- **it must never be possible to fill the tank to more than 80% of its overall capacity;**
- **the tank must not be fitted in the engine bay;**
- **even if an externally fitted tank is provided with protection, there must be a specific distance between it, the road and the sides of the vehicle.**
- **Tanks are usually covered by a ten year guarantee from the date the system was tested as shown on the vehicle registration document. Reference is always made to the standards in force in the country where the vehicle was registered.**

Tank ID plates always show the following information: the make of tank, details of homologation, capacity, dimensions, month/year of production and serial number.

CYLINDRICAL TANKS (FIG. A)

Tanks must be firmly mounted in the transverse position using specific fittings. The strength of these fittings must have been laid down by law. There are also laws that establish it must never be possible to fill the tank to more than 80% of its overall capacity.

The multivalves fitted to cylindrical tanks must come supplied with an airtight chamber.

The capacity and dimensions of tanks are decided upon by their manufacturers.

A

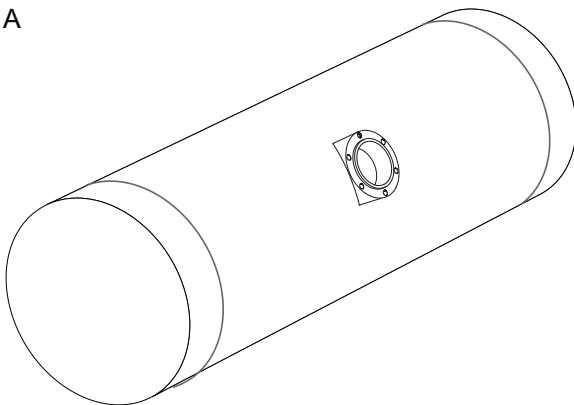

TOROIDAL TANKS (FIG. B-C)

Doughnut tanks are designed to fit in the spare wheel well whether this is inside the luggage compartment or not.

The capacity and dimensions of tanks are decided upon by their manufacturers.

Different makes of tanks with the same external measurements may have differing capacities as in some cases the diameter of the interior of the central section also differs.

The most commonly used doughnut type tanks have the multivalve mounting ring fitted inside the central section (fig. B) or on the external circumference (fig. C). Other types of tank have the multivalve positioned on outer curved surface and come supplied with an airtight chamber. Yet other tanks come with mounting brackets welded to them.

B

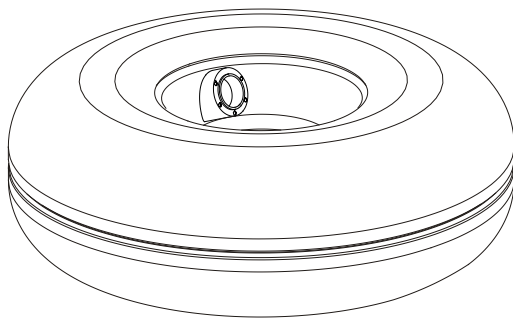

C

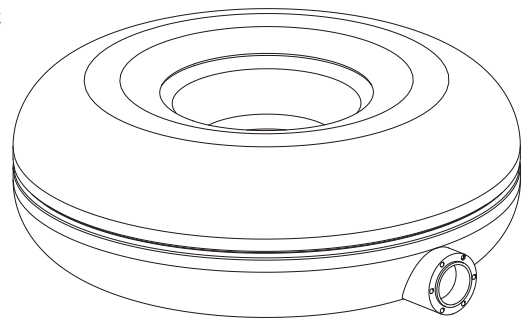

HIGH PRESSURE PIPES

The high pressure pipes are usually made of copper or steel and covered with a rubber protective sheath. In some cases they are made of plastic with special adaptors.

High pressure \varnothing 8 mm metal pipes connect the filler valve and the tank multivalve.

High pressure \varnothing 6 mm metal pipes connect the tank multivalve and the regulator.

In certain specific cases and in some countries, \varnothing 8 mm pipes are used instead of \varnothing 6mm ones for the tank/regulator connection.

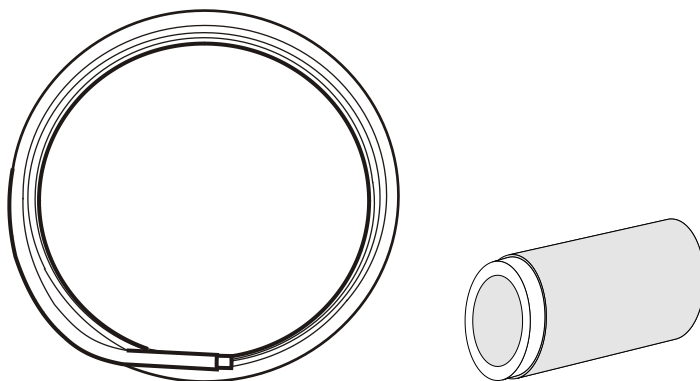

MULTIVALVES

Multi-function multivalves allow gas to enter and exit the tank, provide the ECU with the data it needs regarding fuel levels (if fitted with an indicator) and have thermal fuses and over-pressure valves.

Multivalves are tailor-made to fit tanks of differing diameters and mounting angles (cylindrical tanks) but can also be adapted to allow for height and for internal/external mounting (doughnut tanks).

- A. over-pressure valve/thermal fuse
- B. gas shut-off safety solenoid
- C. manual gas shut-off tap
- D. solenoid homologation
- E. gas outlet joint
- F. multivalve homologation
- G. gas inlet joint
- H. multivalve ID
- I. fuel level indicator
- J. mounting holes(x6)
- K. over-pressure breather tube
- L. float
- M. suction pipe
- N. gasket
- O. protection for external multivalve
- P. airtight chamber for cylindrical tank

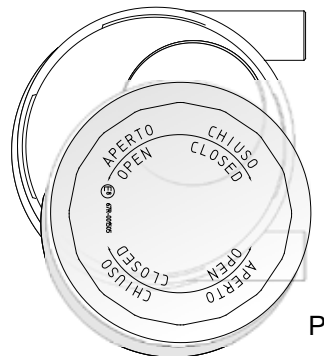
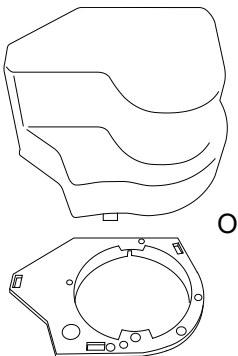
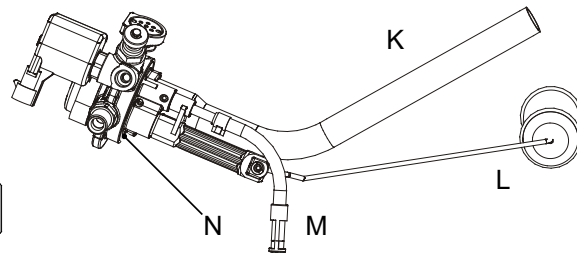
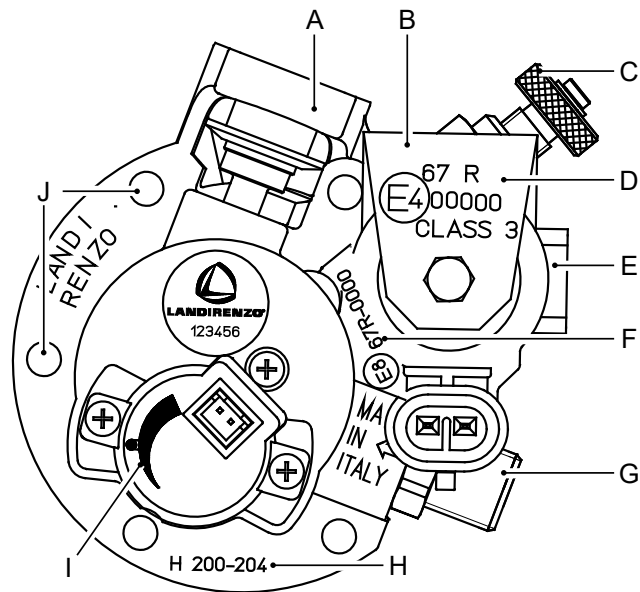

REFUELLING VALVE FOR GASOLINE COMPARTMENT

The fact that the filler is small allows it to be fitted under the petrol filler flap in most commercial vehicles. At present, the different versions of filler valves for filler flaps differ in the type of threading used for mounting the adaptor:

- A: filler valve with internal threading
- B: filler valve with internal and external threading

Various accessories are available for fitting filler valves (see "INSTALLATION").

BUMPER MOUNTED REFUELLING VALVES

This type of filler valve is fitted to vehicles that either do not have a filler flap or where the type of flap prevents installation of the usual filler valve.

TECHNICAL DATA

Connecting pipe:	Ø 8 mm
Mounting hole diameter (version A-B):	Ø 22 mm
Mounting hole diameter (version C):	Ø 60 mm
Threading for pipe retaining nut:	6 mm
Internal adaptor threading:	M10x1.5
External threading for adaptor (version B):	M16x1.5
Torque setting for pipe with compression ring:	tightening min 14 Nm - max 20 Nm

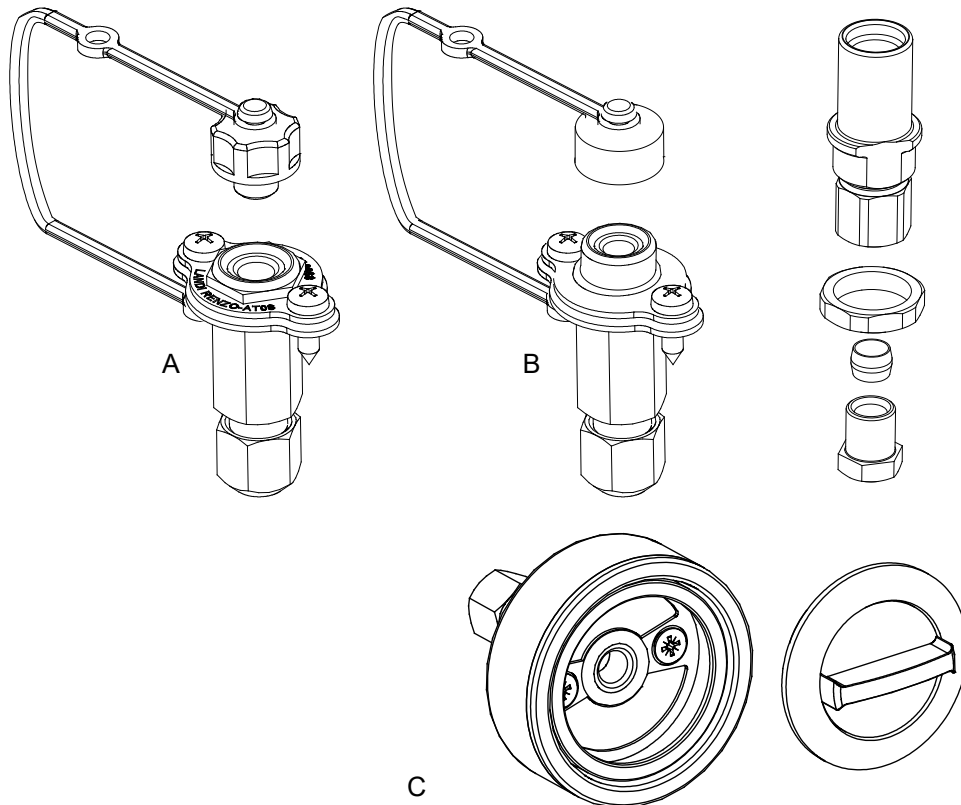

REFUELLING VALVE ADAPTORS

Filler valve adaptors vary from country to country. Each type of adaptor a different length of bayonet.

- D "Italy" for filler valves "A" - "C"
- E "Italy" for filler valve "B"
- F "ACME" for filler valve "B"
- G "Bayonet" for filler valve "B"
- H "EURO" for filler valve "B"

- L adaptor joint for filler valves "A" - "C" and "B"
- M extension for adaptor

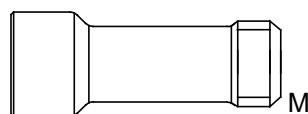
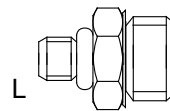
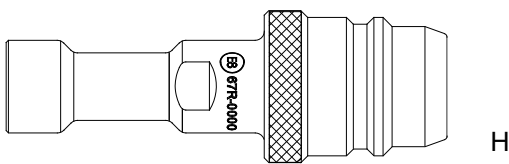
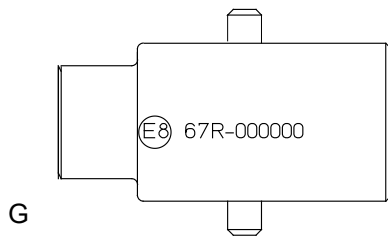
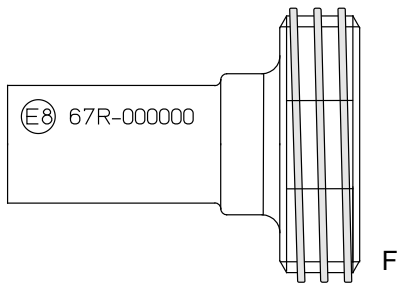
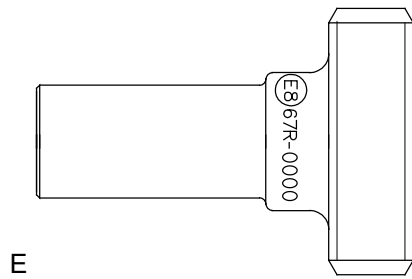
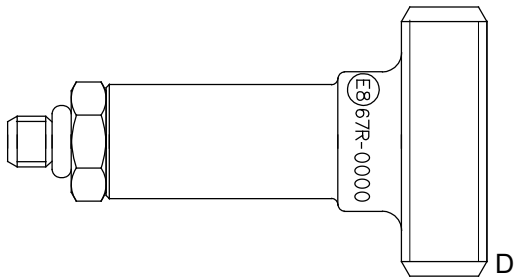

ECE ONU R115-00 (ON KITS THAT COMPLY WITH THAT STANDARD)

ECE ONU R115-00 homologated systems come with a specific label.
This label is supplied by the gas system manufacturer and contains the following information:

- A. number of the European country that approved the homologation;
- B. certification number;
- C. manufacturer's name or trade name.

The installer must use an indelible pen to complete the following fields:

- D. date system installed;
- E. manufacturer and type of regulator/vaporiser;
- F. manufacturer and type of gas system;
- G. manufacturer and type of multivalve;
- H. manufacturer and type of tank.

The label must be stuck to:

- parts of the bodyshell and not on components that can be removed (e.g. battery covers, bonnet lock cross member etc);
- a protected area (e.g.: shock absorber bell housing in engine bay; rear door pillar below the lock latch; spare wheel well in luggage compartment).

The exact locations for sticking these labels are shown in the installation instructions for each type of vehicle.

The diagram shows a rectangular label with rounded corners. At the top left, there is a circled 'E3' followed by the certification number '#115R-000000'. Below this, the label is divided into several sections: a section for 'NAME OR TRADE MARK' (filled with 'LANDI RENZO'), a section for 'TYPE: LPG/CNG' and 'Date:', and a list of components with dotted lines for handwritten entries: 'VAPORIZER / REGULATOR', 'GAZ FUELLING SYSTEM', 'SAFETY DEVICE', and 'CONTAINER'. Below these are three more dotted lines. Labels A through H point to specific fields: A points to the 'E3' symbol, B points to the certification number, C points to the manufacturer name, D points to the date field, E points to the first component field, F to the second, G to the third, and H to the fourth.

INSTALLATION COMPONENTS

BEFORE STARTING INSTALLATION

Carry out the following checks on the engine:

- Check the engine air filter and ignition system (coils, spark plug leads and spark plugs). If necessary, replace any worn items.
- Check that the inlet and exhaust valves (including mechanical valves) have the amount of play recommended by the manufacturer.
- The catalytic converter must be in good working condition.
- The Lambda probe must be in good working condition.
- On vehicles with OBD diagnostic sockets, use a specific tester to check for faults saved to the vehicle diagnostic system memory.

Make any adjustments and/or modifications that the diagnostic system recommends and replace any faulty components as required.

DURING INSTALLATION

- Use an anti-rust product to protect the bodywork where holes have been drilled to mount gas system components.
- Follow the recommendations in this manual and if available, the installation instruction sheets for the vehicle on which the system has to be fitted.

ONCE THE INSTALLATION IS COMPLETE

- When all the components have been fitted in the engine bay, check that all the gas system pipes/hoses and wiring are free of interference and are not too tight.
- Before starting the engine, top up the coolant in the radiator to the mark shown on the expansion tank.

PERIODICAL CHECKS

Once the vehicle has done several thousand kilometres, we suggest you:

- check the regulator pressure;
- check that the regulator heater system is not leaking water;
- check for leaks on the high and low pressure lines;
- check the adaptive parameters on the petrol ECU (OBD parameters for vehicles with this socket);
- check that all the tank retaining bolts are properly torqued down.

For scheduled maintenance, refer to the service stickers in the use and maintenance booklet supplied with the gas system.

NOTE

- Fit the components directly to the bodyshell of the vehicle or use the brackets that come with the kit.
- Do not fit any components less than 150 mm from the exhaust system or silencer(s). If there is no alternative, make sure to fit a shield made of or an equivalent material. This must be at least 1 mm thick. In this case too, do not fit any components less than 75 mm from the exhaust system.
- Make sure that there are no kinks or tight bends in the low pressure lines.

WARNING: Starting from the lowest, the height of the following components should be: regulator, filter and injector rail. The reason for this is to prevent any impurities in the gas from getting into the injector rail.

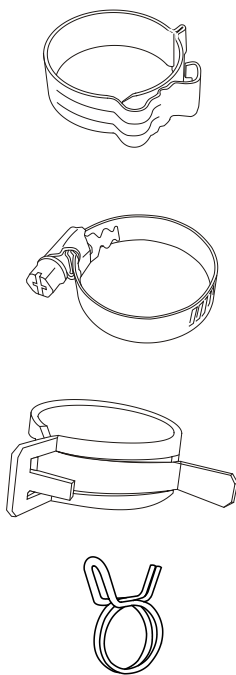

fig. c1

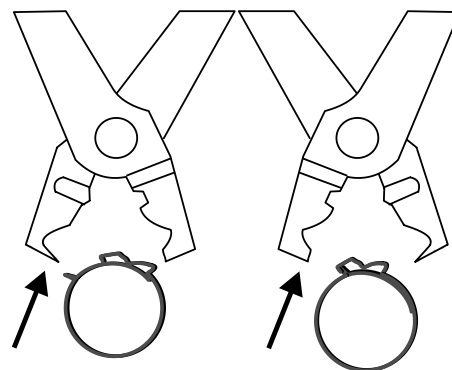
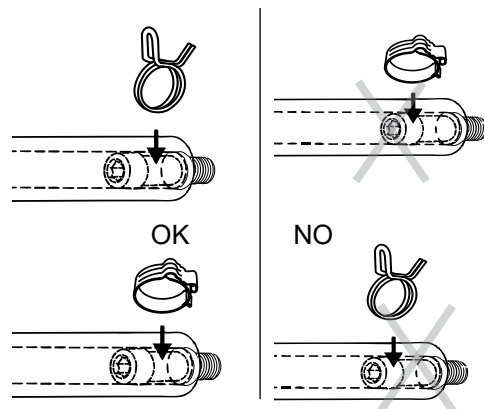
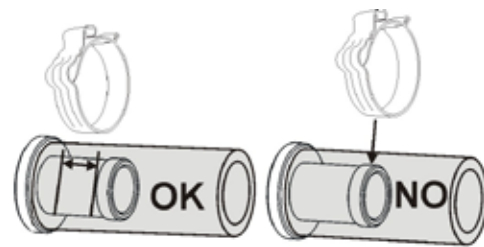
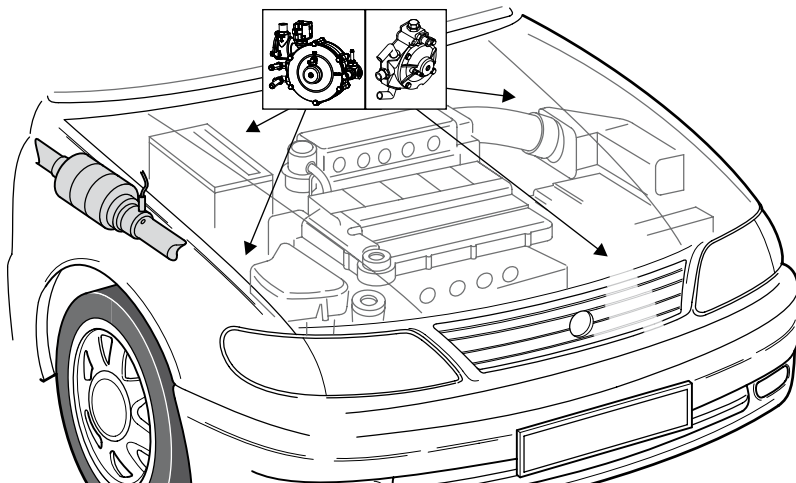

fig. c2

INSTALLING THE PRESSURE REGULATOR

When installing the regulator/vaporiser, follow these instructions:

- install the regulator in the engine bay in an area where it is protected from knocks;
- fit the regulator firmly to the vehicle bodyshell with the specific bracket. The bracket must be shaped to fit the mounting points selected in the engine bay. Take care as regards the following:
- NOT to install the regulator in the windscreen wiper compartment or directly to the engine or any other components mounted on the engine.
- Not to install the regulator upside down (adjuster screw face down, see fig. r2). Other than that, there are no particular restrictions about which way the regulator faces. If possible, it makes life less complicated if the gas joints and regulator screw are easily accessible for maintenance work;
- to install the regulator NOT less than 150 mm ducting and/or the exhaust pipe. If this distance is less than 150 mm but more than 75 mm, a shield made of sheet metal or some other material with similar characteristics will have to be placed between the components. The shield must be at least 1 mm thick.
- to position the regulator lower than the radiator expansion tank to prevent air bubbles from forming in the heating system;
- clean the high pressure pipes carefully before connecting them to the regulator to prevent impurities from getting in;
- connect the regulator heater coolant inlet/outlet joints in series or in parallel using suitably sized hoses and “T” or “linear” joints;
- run the engine and make sure that there are no leaks at the regulator heater joints;
- check that the regulator heats up quickly. Every time you work on the engine cooling system, top up the coolant and make sure there are no air bubbles that might interfere with heating the regulator.
- the following components must be connected in series to the regulator gas outlet (“D” in fig. r4): the filter (optional), the pressure/temperature sensor and the gas metering unit. Care must be taken to ensure that there are no kinks or swollen sections kinks in the pipes/hoses;
- When making the electrical connections, make sure that the solenoid and fuel sensor connectors are properly coupled.



L110 PRESSURE REGULATOR

Mounting:
 maximum depth of the mounting holes: 12 mm
 thread pitch: M6 x 1

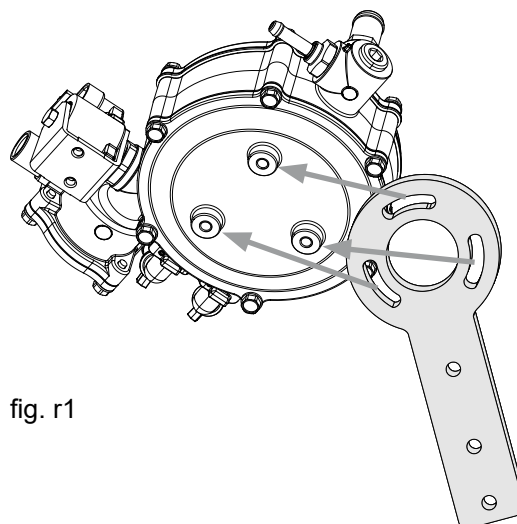

fig. r1

Do NOT install the pressure regulator with the gas outlet joint facing down.

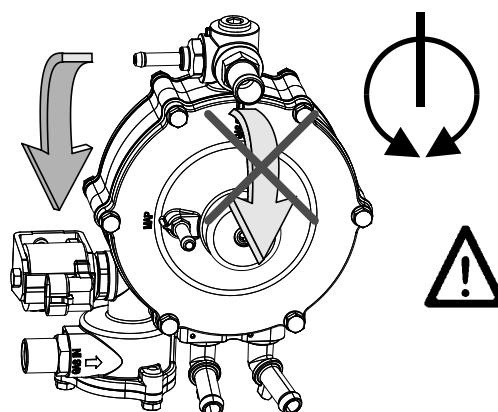

fig. r2

Adjusting the pressure
 Turn the screw anti-clockwise to increase the pressure and clockwise to reduce it.
ATTENTION do not turn the screw more than 6 complete turns in either direction from its original position

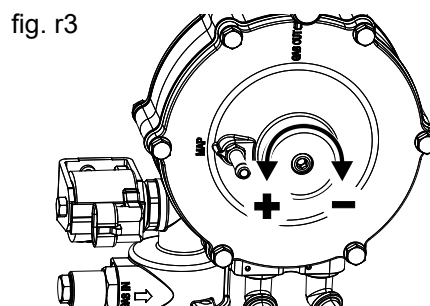

fig. r3

- A. gas inlet joint
- B. hoses for heating liquid
- C. compensation hose
- D. gas outlet pipe
- E. overpressure hose

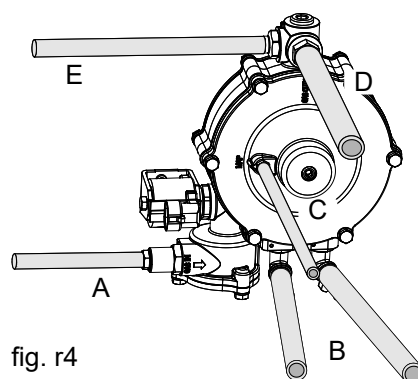

fig. r4

TWO-STAGE PRESSURE REGULATORS

Mounting:

Use the screw with double thread, washers and nut provided.

When preparing the mounting bracket, form a hook to stop from rotating the regulator.

fig. r5

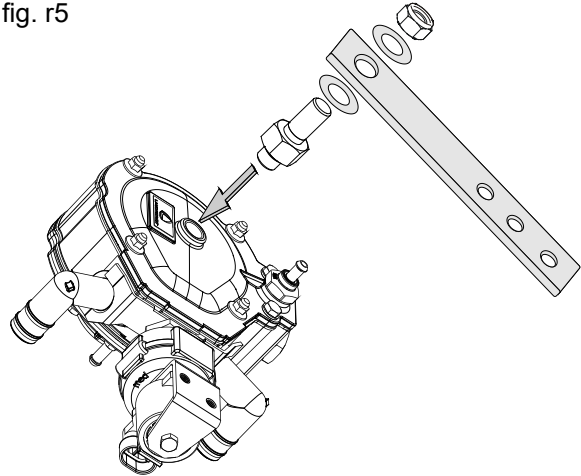

Do NOT install the pressure regulator with the gas outlet joint facing down.

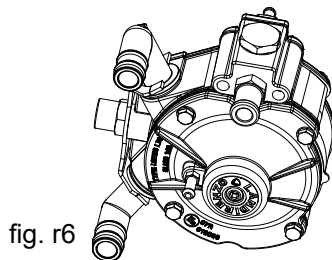
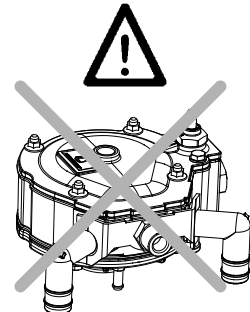
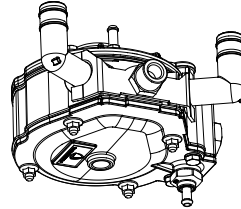
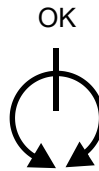

fig. r6



Adjusting the pressure

Turn the screw anti-clockwise to increase the pressure and clockwise to reduce it.

ATTENTION do not turn the screw more than 6 complete turns in either direction from its original position

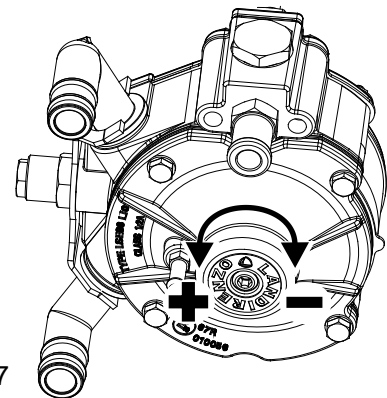

fig. r7

- A. gas inlet joint
- B. hoses for heating liquid
- C. compensation hose
- D. gas outlet pipe
- E. overpressure hose

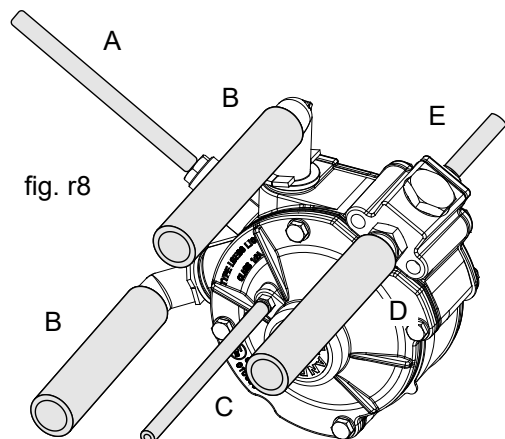

fig. r8

CONNECTING THE HEATER HOSES AND THE TEMPERATURE SENSOR (OPTIONAL)

The regulator heater hoses are usually connected to hoses feeding the heater system radiator. There are no special restrictions as to how this is done.

Connecting in parallel (fig r9)

Identify the "hot" hose that is normally the original hose running from the thermostat. If the regulator is a two-stage unit, connect the hose to the 1st stage joint.

LI10 pressure reducers: is indicated the input "IN" (fig r10).

LI02 pressure reducers: indifferently on one of the connections.

Connect the "cold" hose to the other joint.

Use suitably sized "T" joints for this type of connection. Make a cut of about 15 mm in the original hose where you intend to fit the "T" joint. Insert and tighten the joints with suitably sized clips.

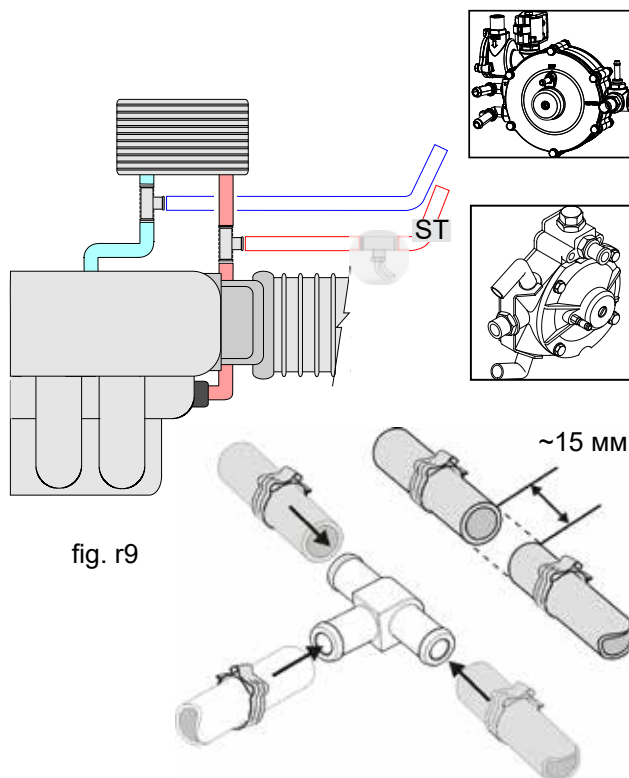

fig. r9

Connecting in series (fig r11)

Identify the "hot" hose that is normally the original hose running from the thermostat. If the regulator is a two-stage unit, cut and connect to the hose from the 1st stage joint.

LI10 pressure reducers: is indicated the input "IN" (fig r10). LI02 pressure reducers: indifferently on one of the connections.

Connect the "cold" hose to the other hose.

Use suitably sized "linear" joints for this type of connection. Insert and tighten the joints with suitably sized clips.

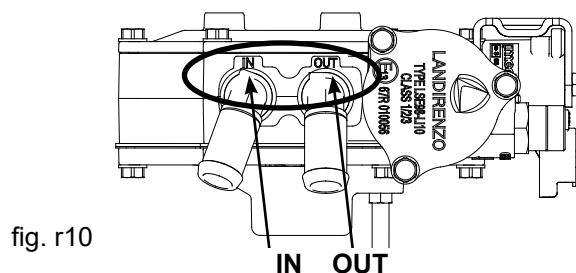

fig. r10

WARNING:

- avoid contact between the clips and other hoses alongside them (fig r12)
- when you have finished, top up the coolant in the radiator expansion tank.

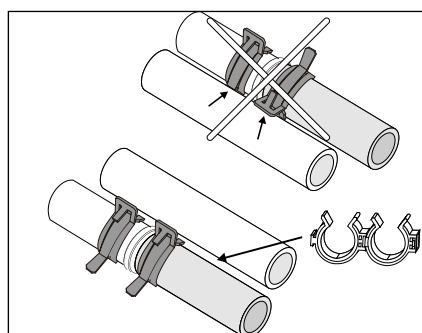

fig. r12

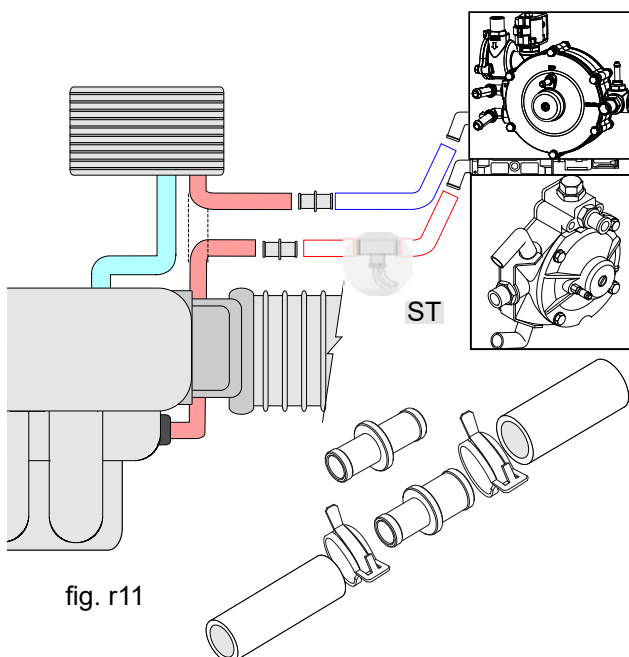

fig. r11

TEMPERATURE SENSOR

Fit the temperature sensor “ST” to the “hot” hose running to the regulator (figs. r9-r11 on the previous page). Fit a pair of Fast-in/Fast-on or 2-way connectors to the ends of the sensor wires and the main wiring harness. Use a cable tie to fasten the Fast-in/Fast-on connectors to a fixed component such as the hose carrying the sensor or some other vehicle component (fig.r13).

Ensure that the wiring is not under strain and that movements of the hose will not later create similar problems (fig.r14).

As an alternative to fitting the temperature sensor, the original vehicle temperature sensor can be connected. In this case, the gas ECU will have to be programmed by acquiring specific parameters from the engine temperature sensor. For details about programming the gas ECU, refer to the specific program documentation.

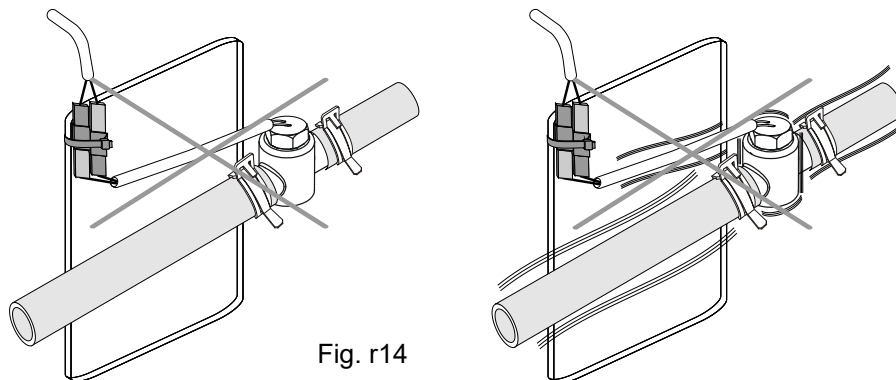
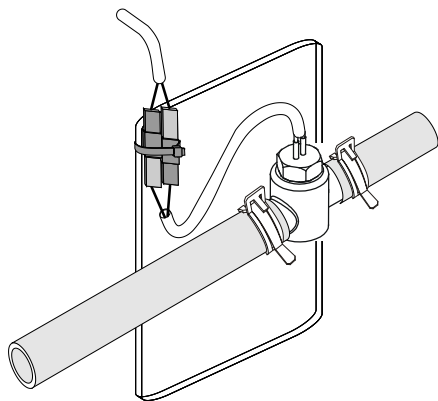
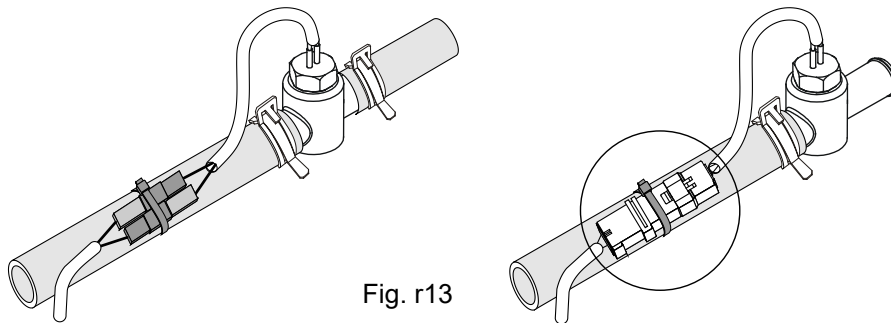

INSTALLING THE FILTER (OPTIONAL)

Filters house a cartridge that effectively filters the flow of gas from the outside to the inside.

When installing the filter, pay attention to the mark on the housing showing the direction of gas flow.

Install the filter in series between the regulator and the injectors (figs.f1-f2). The inlet/outlet joints take hoses with an internal diameter of 14 mm. Position the filter so that it is easy to access for maintenance purposes. Do NOT position the clips on the “collar” of the joint.

There are no particular restrictions about which way the FL-ONE is to face. The FC30 coalescence filter however must be installed vertically with the arrow on the housing facing up (fig. f2).

To avoid interference between the filter or hoses, use an insulated metal clip (e.g. fig.f3) or suitably sized clips (fig. f4) to connect the hoses to other original vehicle hoses or wiring. Make sure that there are no kinks or swollen sections in the hoses.

Write the date and mileage reading of when the cartridge will need to be replaced on the filter housing or in the gas system maintenance manual.

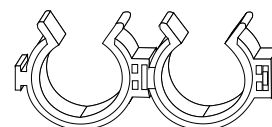
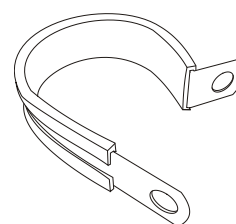
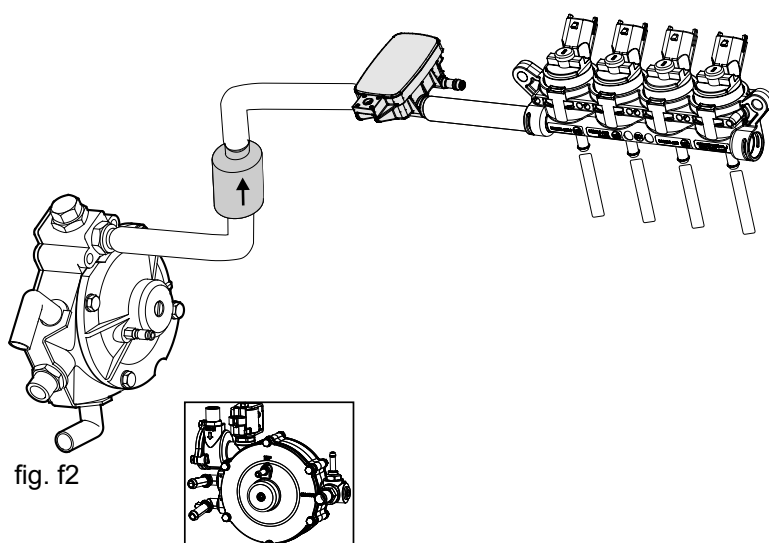
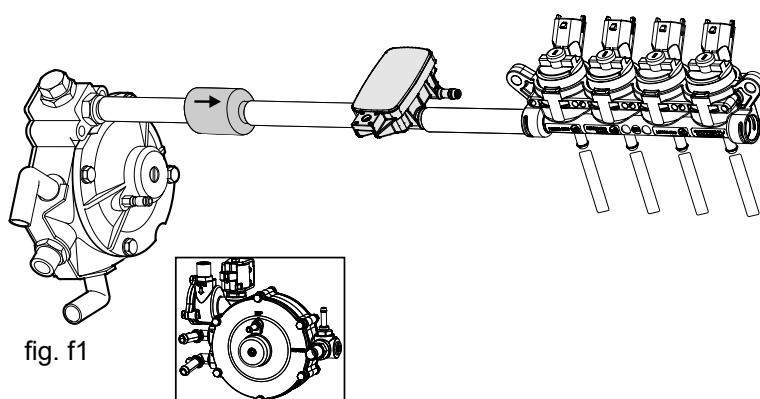

INSTALLING THE GAS PRESSURE/TEMPERATURE SENSOR AND MAP SENSOR

The sensor is to be positioned between the regulator (or filter if fitted) and the injectors. (fig. p2).

Although not obligatory, it is best to fit the sensor to the bodyshell.

There are no particular rules about positioning regarding the gas inlet/outlet and/or vacuum manifold hoses.

The sensor must be positioned in vertical position, or with the connector face down (fig. p1).

The connector has a secondary lock system to ensure it is always connected.

Direction

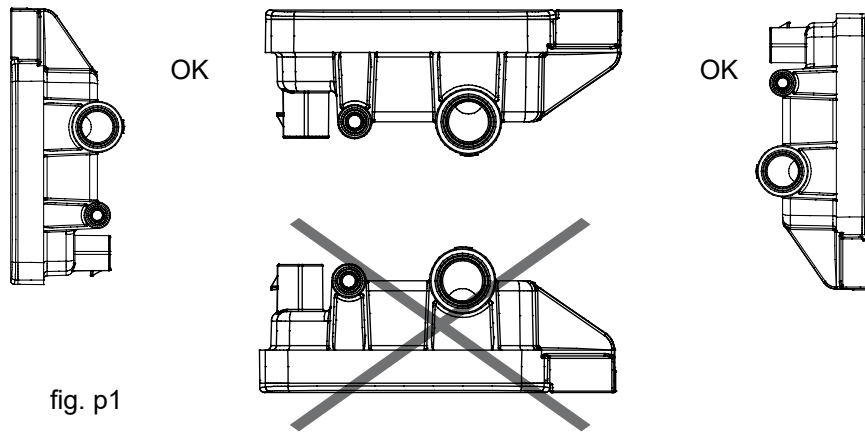

fig. p1

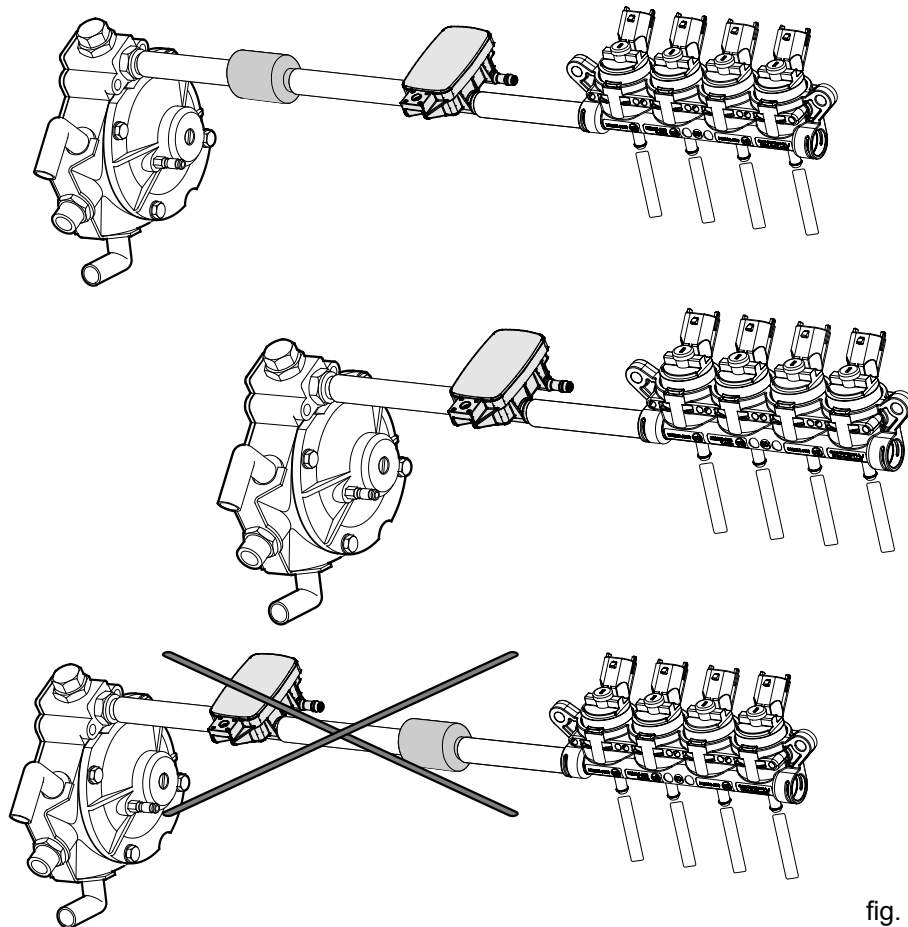

fig. p2

INSTALLING THE GAS INJECTORS UNIT

When installing the injector unit, follow these instructions:

- Identify the best position for installing the injectors while complying with the indications about positioning shown in fig. i5. Gas injector “A” must always be positioned above gas inlet joint “B”.
- At the same time, the injectors must always be positioned as near as possible to the nozzles that inject gas into the branches of the intake manifold so as to reduce the length of connecting pipe work. Lengths of up to 250 mm are acceptable for the pipes connecting the injectors/nozzles as long as the lengths of individual pipes do not vary by more than 50 mm. Long pipes or significant differences between them might create calibration problems.
- The gas inlet joint “B” and the plug “C” can be fitted to the injector unit in whatever manner best suits the pipe work layout (fig i1).
- **Tighten with torque wrench.**
- The injector unit must always be firmly mounted to a stable vehicle component using the “silent blocks” (reference “SB” fig.i1), the nuts and bolts supplied and suitably shaped brackets. The mounting brackets should be shaped to fit the chosen mounting points and the injector unit should never be installed near exhaust manifolds or the catalyser.
- The gas pipe used to connect with the gas inlet joint should have an internal diameter of 14 mm;
- The gas pipe used to connect with the gas outlet joint should have an internal diameter of 6 mm;
- Fit the gas inlet/outlet pipes with suitably sized connectors. Do not place the connectors on the “collar” of the joint connectors (see fig. c1 “NOTE” at the start of this section);
- Make sure that there are no kinks in the hoses.
- The connections between the gas injector wiring and the petrol cut-out wiring (fig. i6, i7, i8 and “Petrol injector cut-out wiring”) are interconnected when doing the wiring up, make sure that the injector wiring is properly connected;
- Make sure that the pipes and wiring are protected from engine vibrations that could lead to damage;
- Protect the pipes and wiring where they come into contact with engine components and make allowance for engine vibrations that could put in gas inlet pipe and wiring under strain under certain conditions.
- When installation is complete, check for gas leaks at the gas inlet joints when the engine is running on gas.
- Injector units do not have any specific maintenance requirements.
- Avoid the use of cleaning products or injector lubricants to be mixed with the gas.
- If the injector unit needs cleaning, remove it and use special injector cleaning equipment.
- Never tamper with gas system components especially if the engine is running or the ignition is on.

Fitting the injectors GIRS12

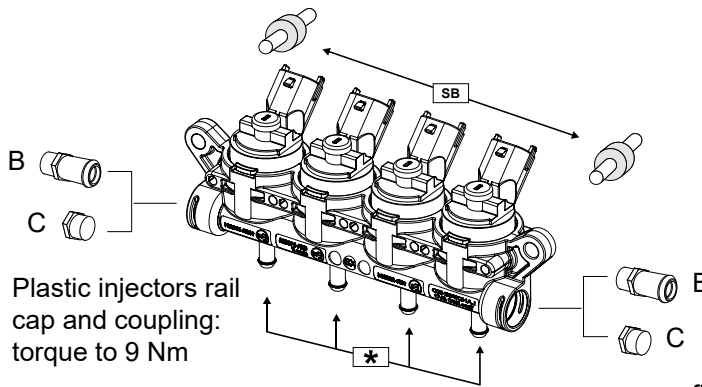

Plastic injectors rail
cap and coupling:
torque to 9 Nm

fig. i1

Injector layout

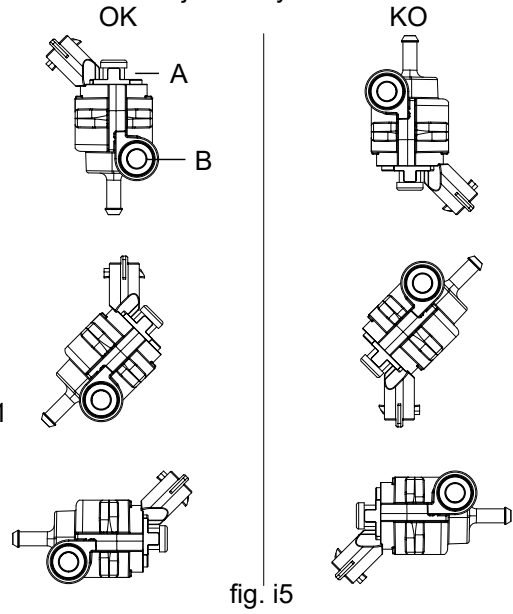

fig. i5

EVO Fitting injectors

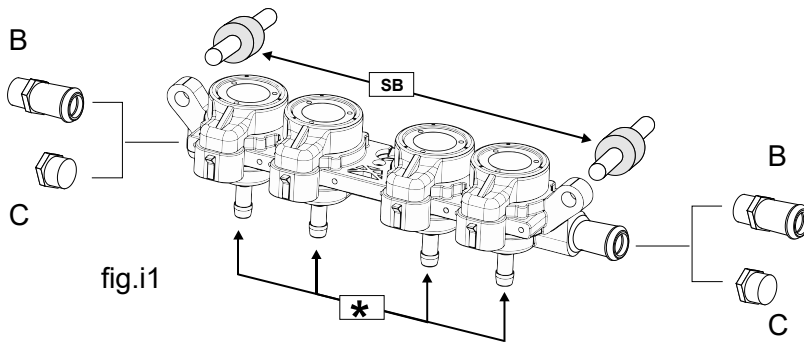

fig.i1

Injector layout

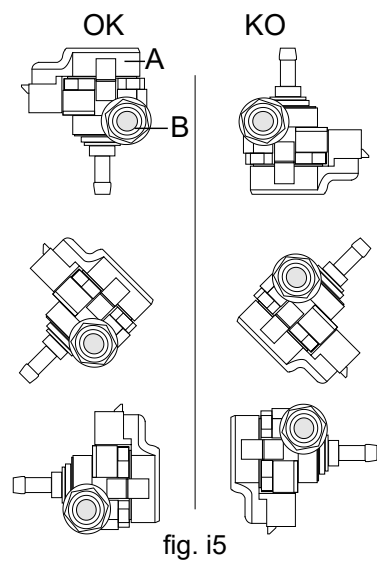

fig. i5

fig.i2

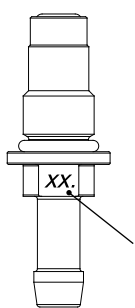

fig.i3

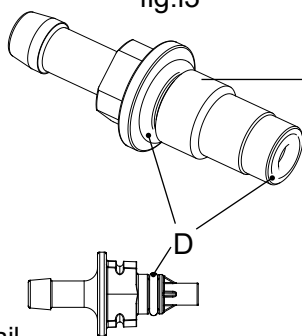
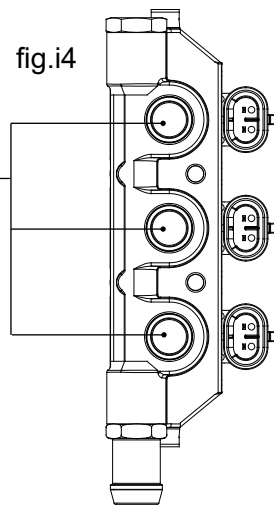

fig.i4



Metal injector rail
cap and coupling: torque to 12 Nm
nozzles: torque to 9 Nm

Plastic injector rail
cap and coupling: torque to 9 Nm

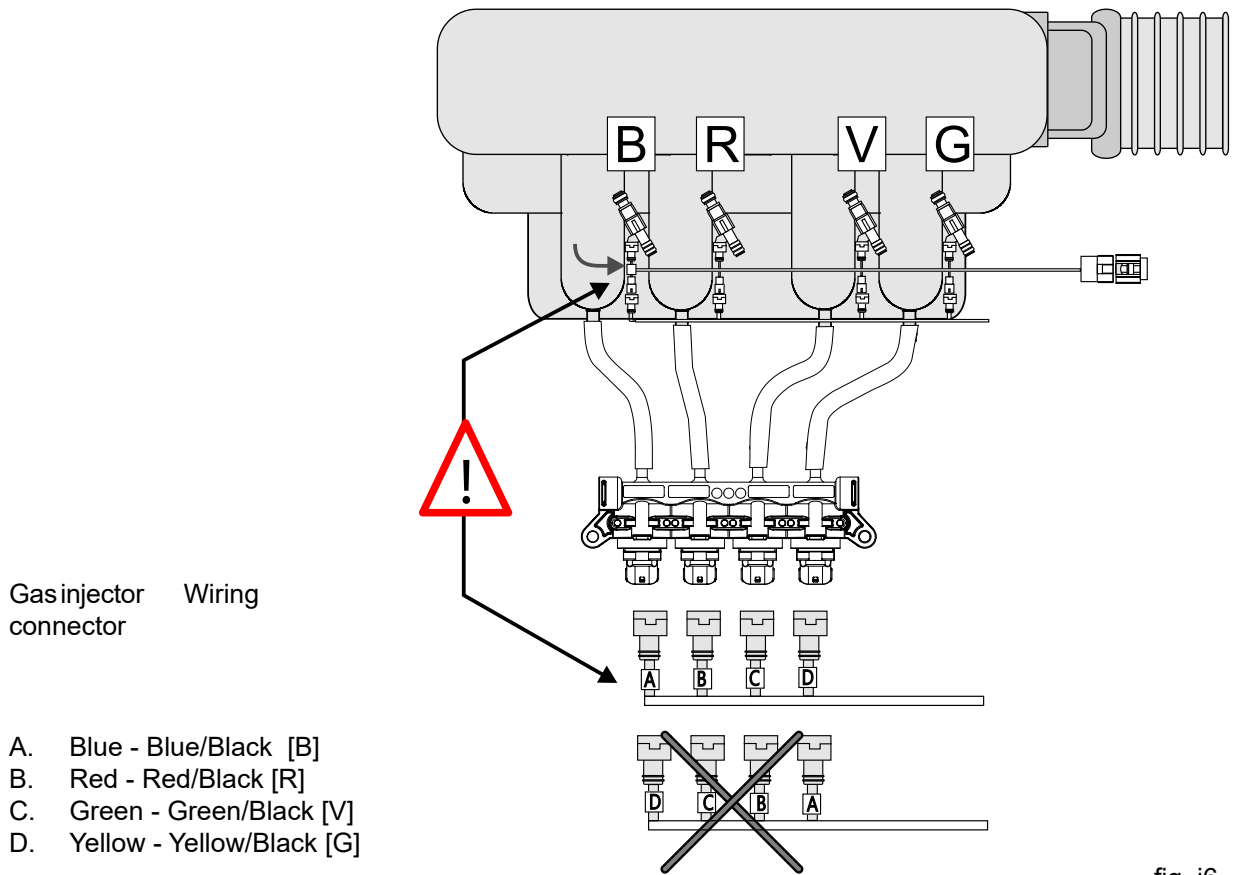

fig. i6

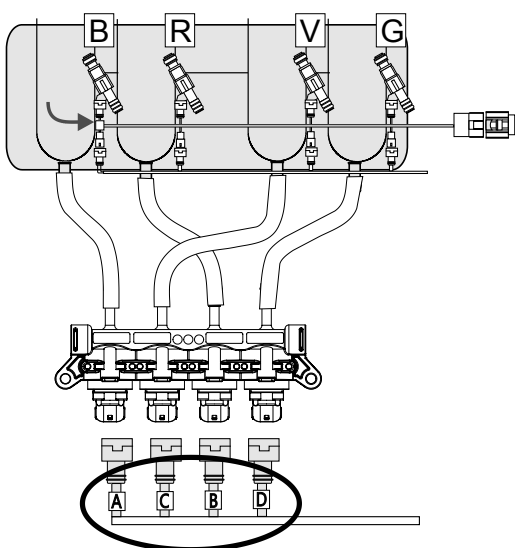

fig. i7

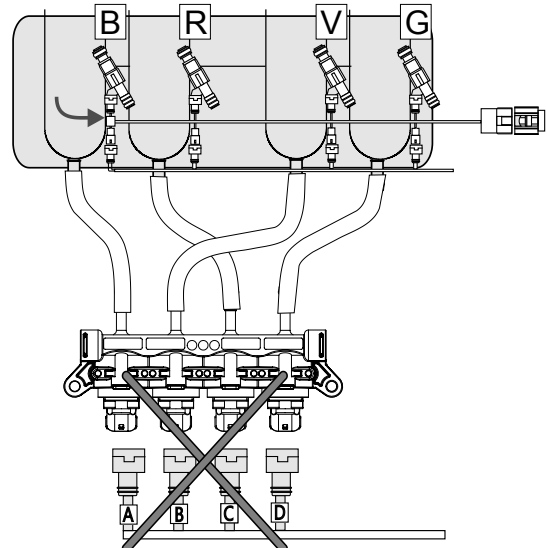

fig. i8

FOR CONNECTION 5-6-8 CYLINDER SEE PAGE. 92

INSTALLING THE NOZZLES

NOZZLES FOR INJECTORS

The best position for installing the nozzles on the intake manifold is the alongside the cylinder head flange (fig.u1).

There are no specific restrictions about where to drill although it is best if the nozzles are fitted as near as possible to the flange and possibly at the same distance from the head (see fig.u2). This facilitates calibrating the fuel mix. A difference of about 10mm between where one nozzle and the next is located is acceptable. When an engine/ECU-specific KIT is available, follow the instructions in the installation manual.

Where nozzles are positioned on the bend of the intake manifold branch is not an absolute (fig.u3) but it is essential that, where possible, the nozzle outlets are pointing in the same direction as the air flowing into the manifold (fig.u4).

Bore Ø 5mm holes on the metal part of the intake manifold and thread with a M6 x1 tap.

Bore Ø 4.75mm holes on the plastic part of the intake manifold and thread with a "medium" M6 x1 tap.

Nozzle for inside manifold (fig. u6).

Use this type of nozzle when you have to fit the nozzles far from the intake valves or if for some reason there are problems finding optimal calibration.

Apply a bead of thread sealant to the threads on the nozzle. Make sure to use the appropriate metal/metal or plastic/metal sealant.

NOTE

Nozzles with conical threads

Do NOT use excessive force when tightening these nozzles as you may damage the threads cut into the manifold (fig. u5).

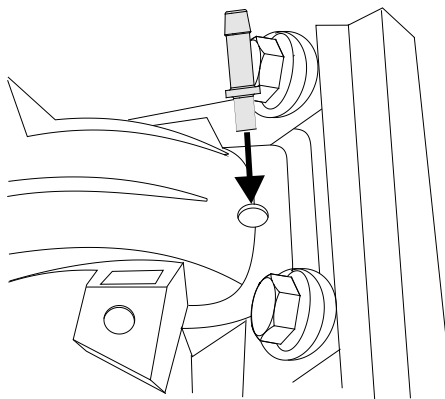

fig. u1

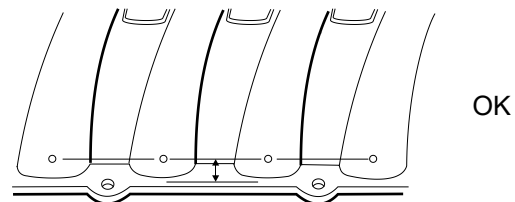

fig. u2

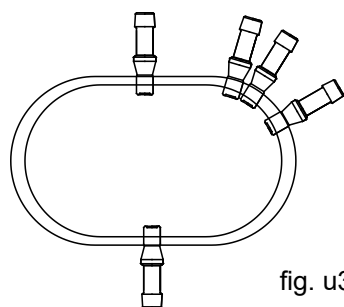
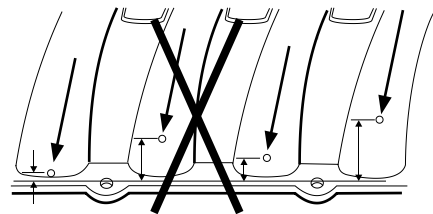

fig. u3

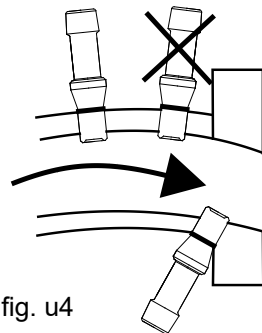

fig. u4

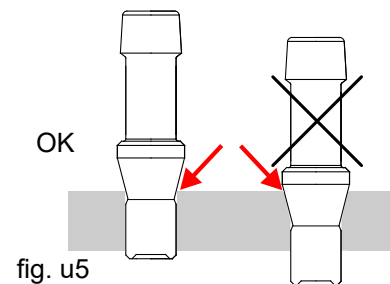

fig. u5

NOZZLE FOR THE COMPENSATION OF THE PRESSURE REGULATOR

Fit the compensation nozzle to the common chamber of the intake manifold and, when possible near the throttle body. Do not position the nozzle on an individual branch of the intake manifold (fig.u9 ref. A).

On metal intake manifolds, bore \varnothing 5mm holes and thread with a M6 x1 tap.

On plastic intake manifolds, bore \varnothing 4.75mm holes and thread with a "medium" M6 x1 tap.

Apply a bead of thread sealant to the threads on the nozzle. Make sure to use the appropriate plastic/metal or metal/metal sealant.

The regulator compensation hose can be connected to original engine vacuum hoses this avoiding having to fit the nozzle to the intake manifold. Cut the original hose and make the connection with a suitably sized T joint (fig. u7).

NEVER CONNECT THE VACUUM HOSE TO THE BRAKE SERVO.

Engines in which air flow is managed by the intake valves. In this case, there is no need to install the compensation nozzle and connect it to the regulator.

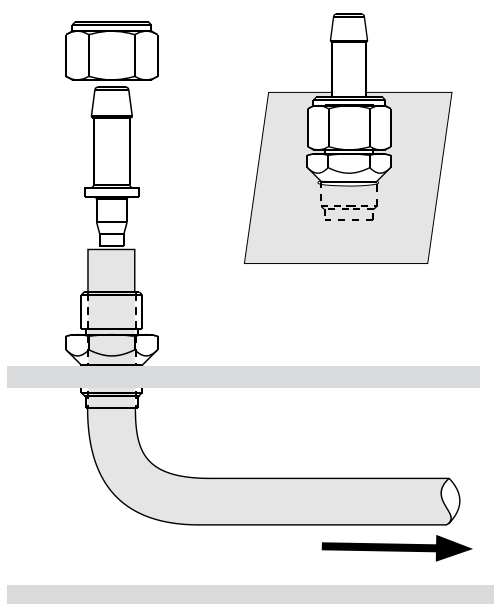

fig. u6

fig. u7

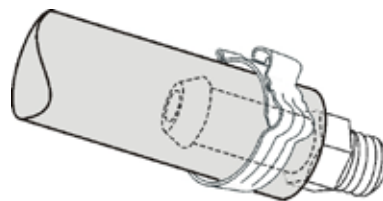
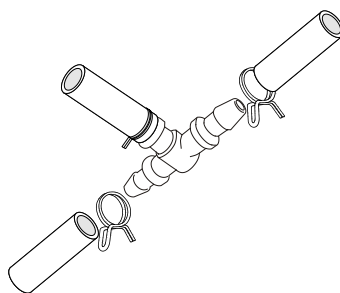

fig. u8

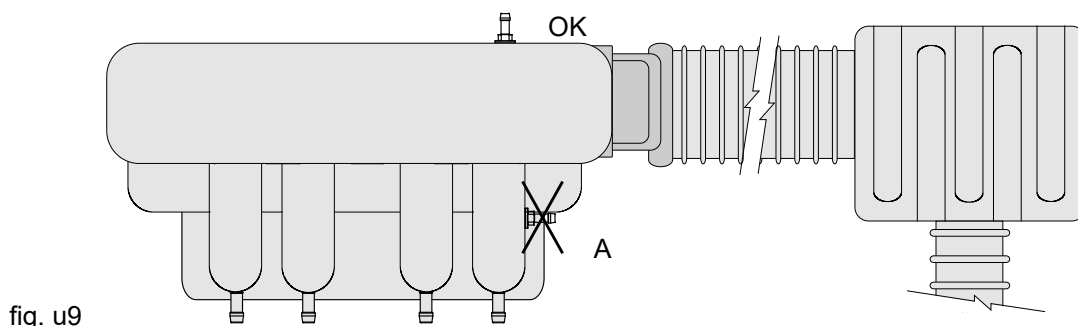
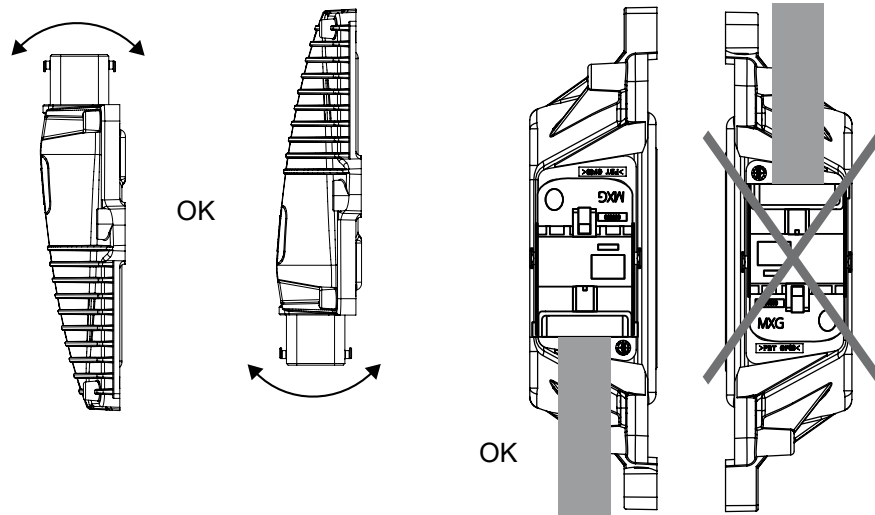

fig. u9

INSTALLING THE ECU

- If the installation manual is not available, choose the position for mounting the ECU with care.
- The best place for the ECU is in the engine bay away from hot areas such as near the exhaust manifold, radiator etc. If possible, the ECU should also be located near the battery.
- Fit the unit so that it can be easily accessed for programming/diagnostic purposes.
- Make sure that the ECU is protected against liquids (such as rain or engine cleaning products) that might accumulate inside the connector.
- Fit the ECU directly to the body work of the vehicle or use the specially shaped bracket that lets the unit hook on to two slots.

Direction



*OMEGAS and EVO

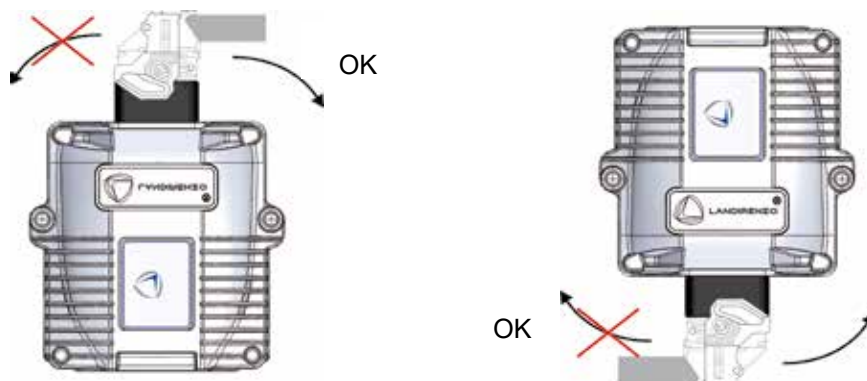

INSTALLING THE SWITCH

Choose the position for mounting the switch with care.

The switch should be positioned in the dashboard area where the driver can see and hear it. Although we advise against placing the switch near the gear lever as the driver has to take his/her eyes off the road to see it, it is nonetheless acceptable. Avoid gloveboxes, drinks trays and areas covered by the steering wheel that are difficult to see. These instructions are covered by legislation in some countries.

SQUARE SWITCH

Drill a Ø 12 mm hole into a flat surface of the dashboard. Avoid curved surfaces for the best result (fig.m4). Clean the dashboard of dust and feed the wiring through the hole. Remove the adhesive backing and stick the switch in position.

ROUND SWITCH

Drill a Ø 25 mm hole into a flat surface of the dashboard. Avoid curved surfaces for the best result (fig. m4). Clean the dashboard of dust and feed the wiring through the hole, fix the switch making sure that the interlocking flaps are positioned correctly.

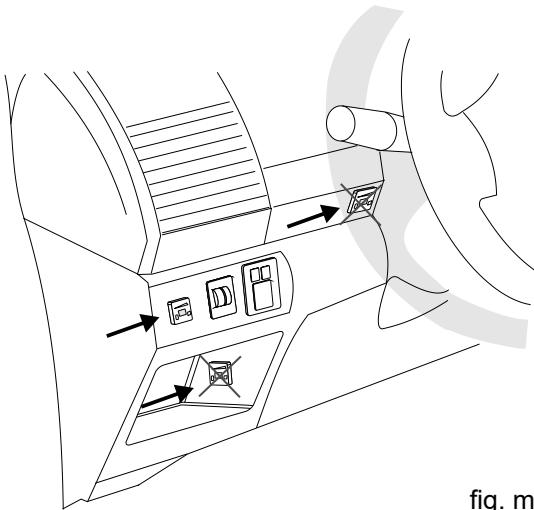

fig. m1

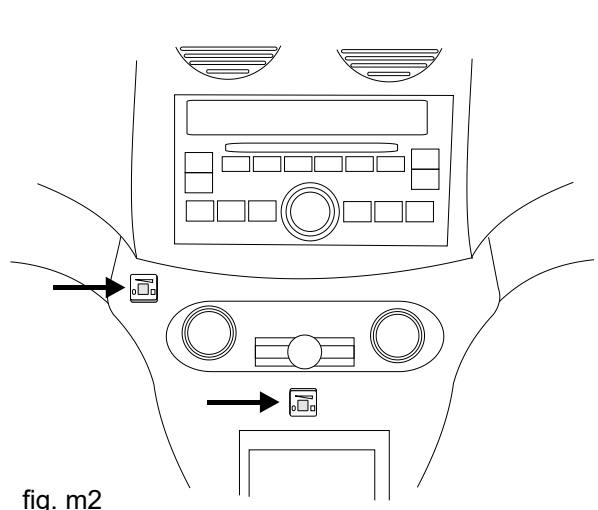

fig. m2

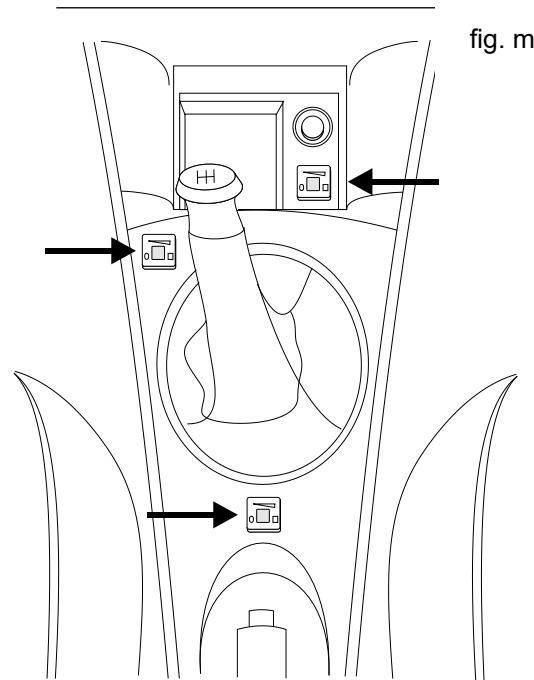
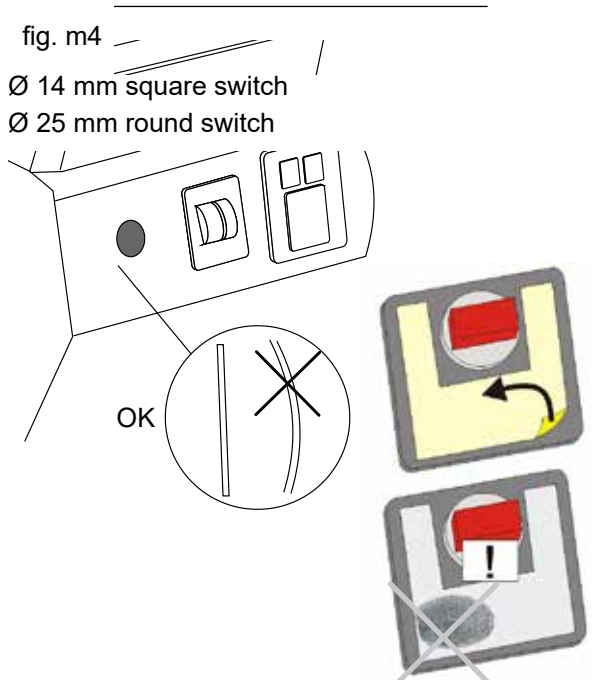

fig. m3



CYLINDRICAL TANK

Install the cylindrical tank across the back of the luggage compartment.

The tank can be locked in position using:

- telescopic bars with terminal block (fig. s1)
- telescopic bars with snap on terminal (fig. s2)
- special frames (fig. s3)
- L-shaped bars (fig. s4)

The tank should not be in "DIRECT" contact with any metal components of the vehicle.

Fitting with the telescopic bars (figs. s1-s2):

Fit the bars "2" to the inside of the wheel arches at a distance above the floor that will prevent the tank from touching it (fig. s7).

Fit the rubber gasket "4" between the bars and the tank so as to prevent contact between them.

Fit the straps "6" to one of the bars (seen from above fig. s8).

Position the tank on the bars and rotate it as required to suit the selected multivalve (fig. s6). The ID plate should also be clearly visible. To position the multivalve retaining ring in the correct position, we suggest you use a suitable protractor (fig.s7).

Fit the gasket "5" between the tank and the clips so as to completely separate both components.

Adjust the length of the straps "6" to suit the tank diameter and hook them to the support bars "7" tucking the end of the straps (at least 100mm) between the strap itself and the gasket. (seen from below fig. 8).

Bolt the support bars in position with the bolts "8" provided.

Fitting with the special frame (fig. s3) or L-shaped bars (fig. s4)

Fit the frame or L-shaped bars to the floor of the luggage compartment at a distance above the floor that will prevent the tank from touching it. For the number of fixing points for frames and L-shaped bars and for the types of nuts and bolts to be used, refer to the standards that apply in the country where the tank is being installed. For the rest of the installation procedure, follow the instructions below.

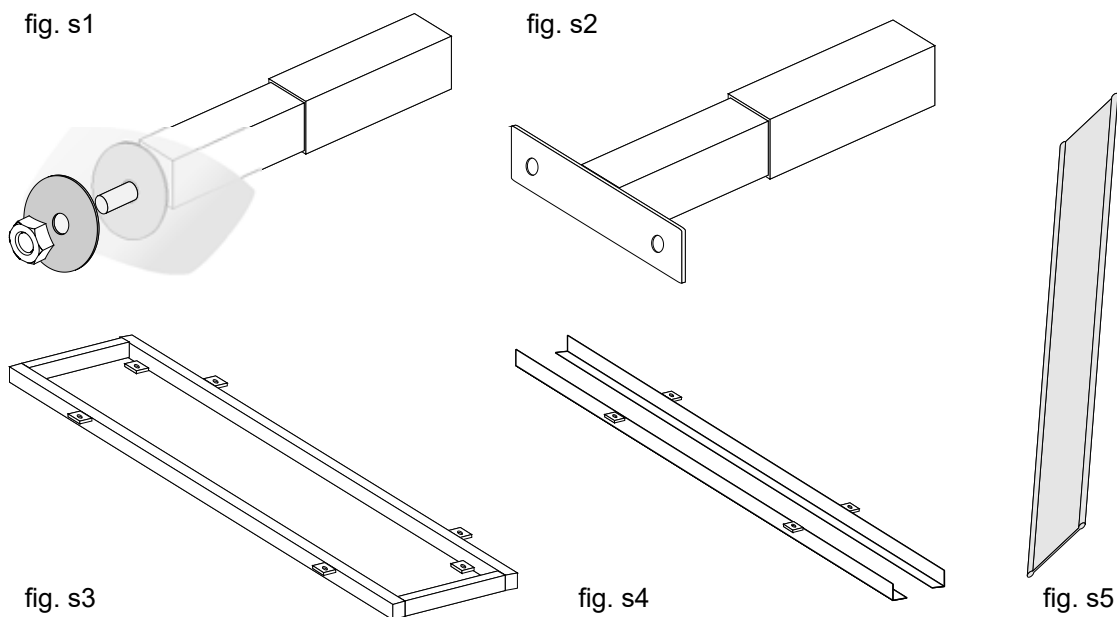

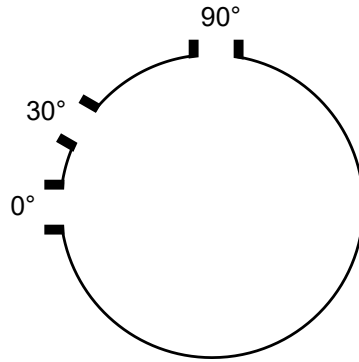

fig. s6

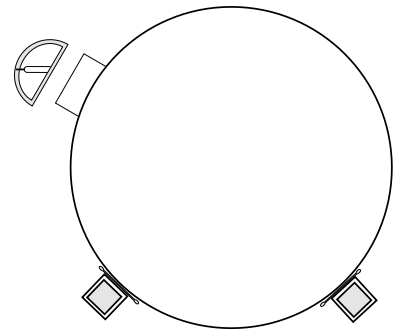
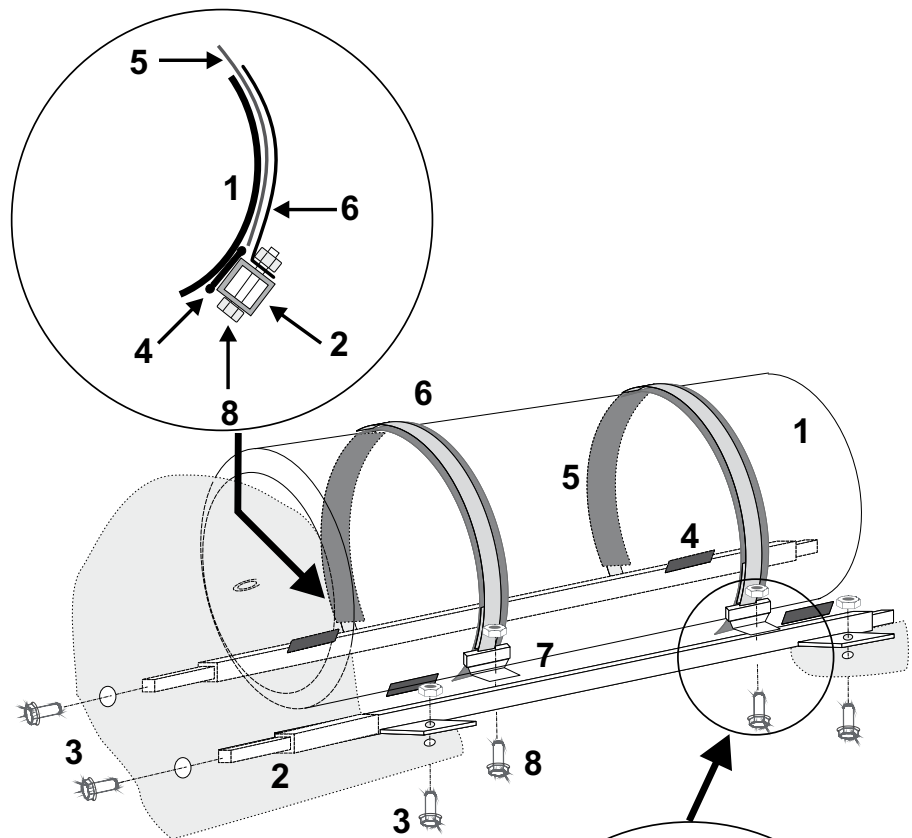

fig. s7

fig. s8



1. Tank
2. Telescopic bars (30x30x2mm)*/Tank frame (material Fe 360 minimum angular dimensions 40 x 40 x 5 mm)*
3. Bar/frame retaining bolts with washers (bolts: M10 class 8.8)*
4. Insulating gasket
5. Under-strap gasket
6. Fixing straps (30 x 3 mm)*
7. Support bars
8. Retaining bolts for adjustable straps/frame

* these values can vary from country to country

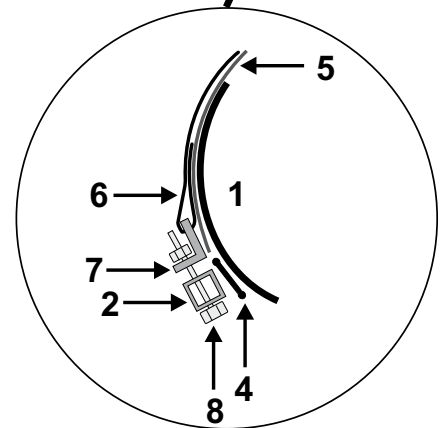

INTERNAL / INTERNAL TOROIDAL TANK

Install the tank in the spare wheel well in the luggage compartment.

The fixing kit includes nuts and bolts, external bracket and grommets. In vehicle-specific kits, spacers and high pressure pipe protective sheaths are also usually supplied.

Assembly:

Bend (do not cut) any ring on the outer circumference or any other similar component used by the manufacturer to make the tank (fig.s9)

Place the tank in the wheel well with the multivalve ring facing the rear of the vehicle (fitting it like this facilitates scavenging gas when the vehicle is going uphill).

Use the tank and the external bracket "H" as a template for drilling. Bore one Ø 50mm and two Ø12 mm holes. Remove the tank, put in on the workbench and clean away any residue from drilling. Fit the multivalve (see specific section).

Protect the vehicle bodywork with an anti-rust product.

Position the sheet of insulation between the tank "G" and the floor.

Position the spacers "F" (if available) over the holes for the retaining bolts.

Position the tank.

Insert the bolts "B" from above followed by the metal washer "C" and the insulating washer "D". Make sure that the bolts go through each of the spacers positioned beforehand.

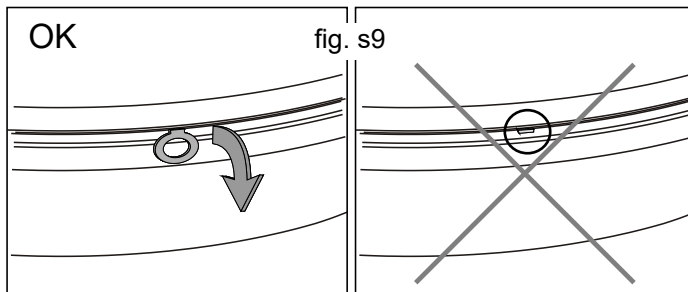

Insert the grommets "E".

Apply a bead of silicone along the edge of the holes and of the external bracket "H" (fig. s11).

Fix the external bracket in position with nuts "L". Use a torque wrench to tighten the nuts to 28 Nm.

Spread any excess silicone evenly along the edge of the bracket.

Cut the grommets "E" to match the external bracket.

Pass the high pressure pipes and multivalve wiring through the grommets.

Connect the pipes and wiring to the multivalve. Only after installation is complete and you have carried out leak tests, fit the protective sheaths "M" (if supplied) to the pipes as well as the spacers and the cover for the central chamber "A".

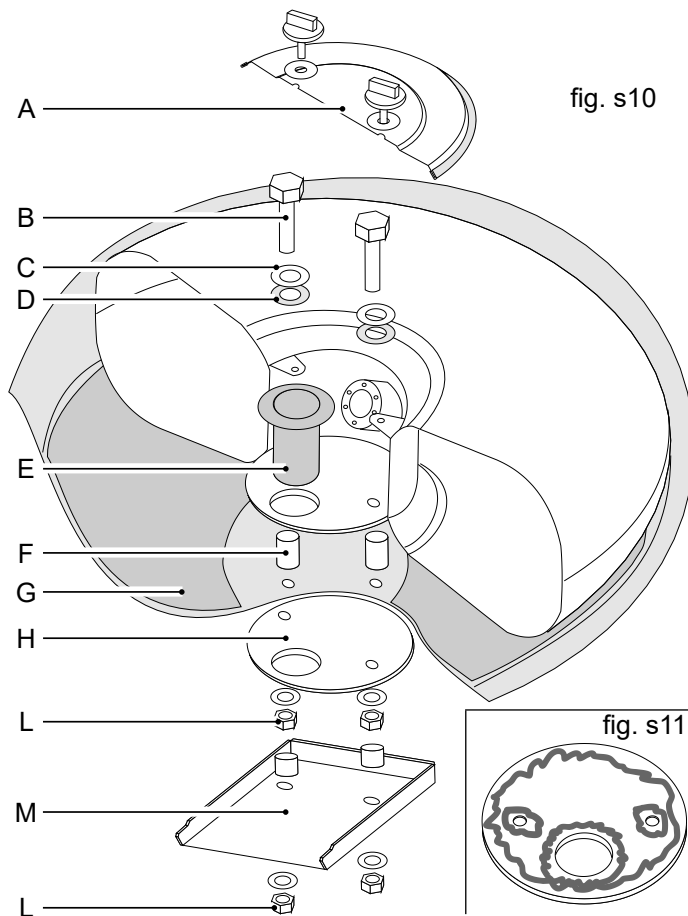

INTERNAL / EXTERNAL TOROIDAL TANK

Install the tank in the spare wheel well in the luggage compartment (fig. s12).

The fixing kit includes nuts and bolts and the external bracket.

Assembly:

Bend (do not cut) the ring on the external circumference (fig. s9).

Decide which is the best side of the vehicle for drilling. Allow a distance of at least 50 mm between the multivalve and the vehicle bodywork.

Drill a hole of about Ø 80 mm. Place the tank in the wheel well. Use the tank as a template and drill two Ø12 mm holes. Protect the tank and vehicle bodywork with an anti-rust product.

Remove the tank, put in on the workbench, clean away any residue from drilling then fit the multivalve (see specific section).

Position the sheet of insulation between the tank and the floor.

Position the spacers (if available) over the holes for the retaining bolts.

Position the tank. Insert the bolts from above followed by the metal washer and the insulating washer. Make sure that the bolts go through each of the spacers positioned beforehand. Fix the external bracket in position with nuts. Use a torque wrench to tighten the nuts to 28 Nm. Seal the hole in the bodywork around the multivalve with silicone. Fit the multivalve with the protective base (see specific section). Connect the high pressure pipes and wiring. Close the multivalve cover.

EXTERNAL / EXTERNAL TOROIDAL TANK

Fit the tank under the luggage compartment floor (fig.s13).

Put the vehicle up on a ramp to identify the best position for the tank. Allow a distance of at least 50 mm between the multivalve and the vehicle bodywork.

fig. s12

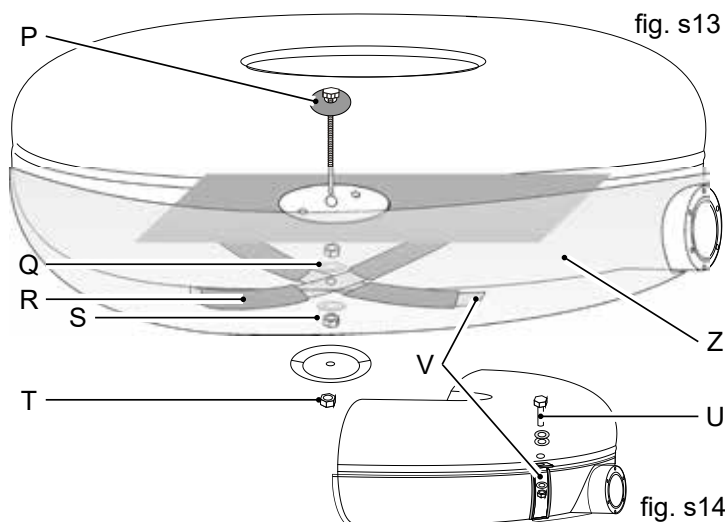
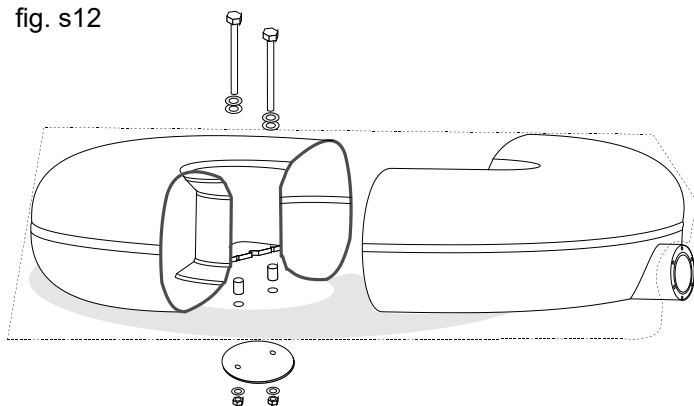

Identify the four mounting points for the straps that must be on a flat surface and drill four Ø 12 mm holes. Protect the bodywork with an anti-rust product and fit the M10 bolt and washers "P" inside the luggage compartment.

Fit the appropriate bolts and washers to the central chamber of the tank.

Position the insulating disc between the tank and the floor.

Fit the insulating gasket "R" between the insulating gasket "V" and the tank so that the tank is completely insulated. Torque the straps down to the floor with bolts "U" to 28 Nm.

Drill a Ø12 mm hole on the strap to match the position of the middle bolt.

In sequence, fit the central bolt with: nut and washer "Q", strap "V", washer and nut "S". Torque the lower nut "S" to 28 Nm. Tighten the upper nut "Q" as normal. Fasten the lower tank protection "Z" in position with the Ø washer and self-locking nut "T".

Fit the multivalve with its protection, connect the high pressure pipes and wiring (see specific section).

USE OF MULTIVALVES ON CYLINDRICAL TANKS

Multivalves with the ring set at differing angles are available for differing tank positions:

- 0° type: ring in horizontal position
- 30° type: ring at an angle of 30°
- 90° type: ring in vertical position

We suggest you use a specific protractor to position the tank correctly.

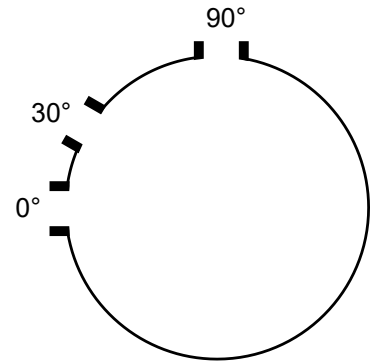

fig. v1

USE OF MULTIVALVES ON TOROIDAL TANKS

Depending on tank type, use Multivalves with the ring set at differing angles:

- 0° type: for internal/external or external/external tanks
- 30° type: for internal/internal tanks

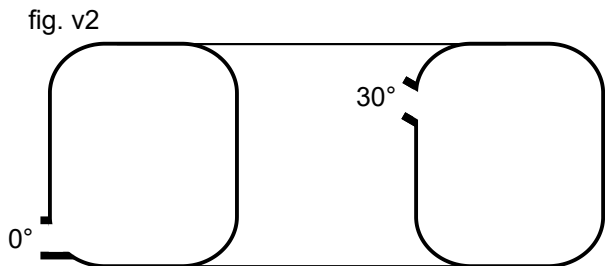

fig. v2

FITTING THE MULTIVALVE (EXAMPLE ON TOROIDAL TANK)

If the threads on the ring have not been protected by bolts, remove any shavings from drilling or paint residue from the multivalve mounting holes on the ring and, if necessary, thread the holes with a "fine" "M5x1" tap.

Fit the multivalve taking care not to force or bend the float rod or suction pipe. Take care not to entangle the suction pipe "Q", the float rod "P" and the gas discharge pipe "N" (fig. v4).

Install in sequence:

- Float rod
- Gas discharge tube
- Suction pipe

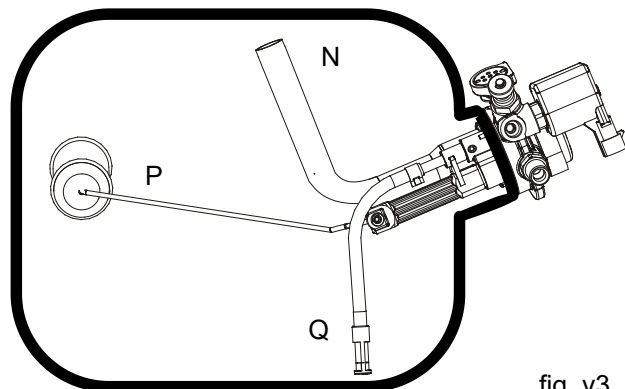

fig. v3

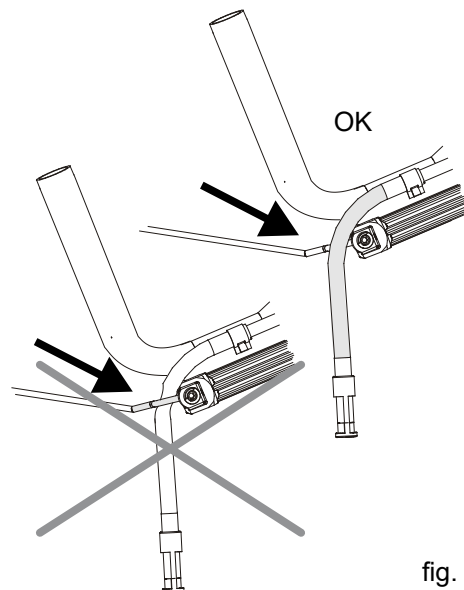

fig. v4

AT02 SERIES MULTIVALVE

Correct positioning of the “30°” multivalve in relation to horizontal.

Further adjustment involves positioning the gas inlet face down.

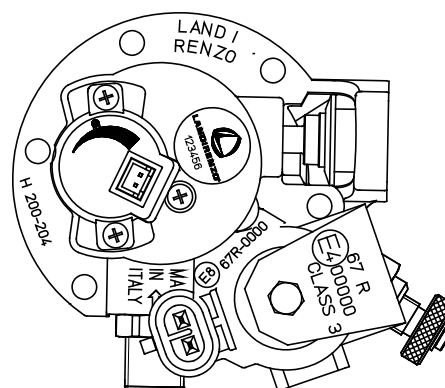

fig. v5

Correct positioning of the “0°” multivalve in relation to horizontal.

Further adjustment involves lining up the two mounting holes on the side of the over-pressure valve (shown) with the upper holes on the tank ring.

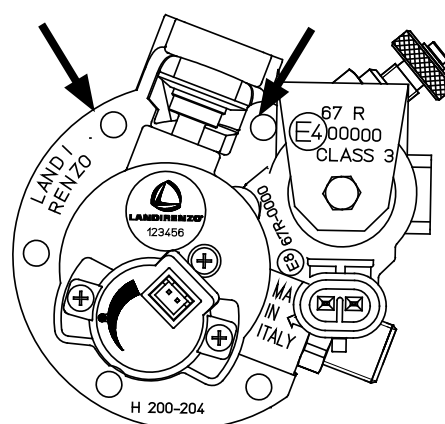

fig. v6

Tighten up the bolts with a “4mm” hex socket then torque them down in an alternating sequence to 5 Nm.

Fit the Ø 8 mm gas outlet and Ø 6 mm gas inlet pipes and tighten by hand.

Use a torque wrench to tighten the Ø 8mm to 14 Nm and the Ø6 mm pipe to 11 Nm.

Connect the electrics:

- wiring for fuel level indicator “U”
- wiring for solenoid “V” power supply

The fuel level indicator can be assembled in three different configurations.

Usually the fuel level indicator is fitted with the bolts in the central holes (as in the diagrams). If however, the switch signals an error, the position of the indicator can be changed after the tank has been filled.

Further details are provided in specific multivalve installation manuals.

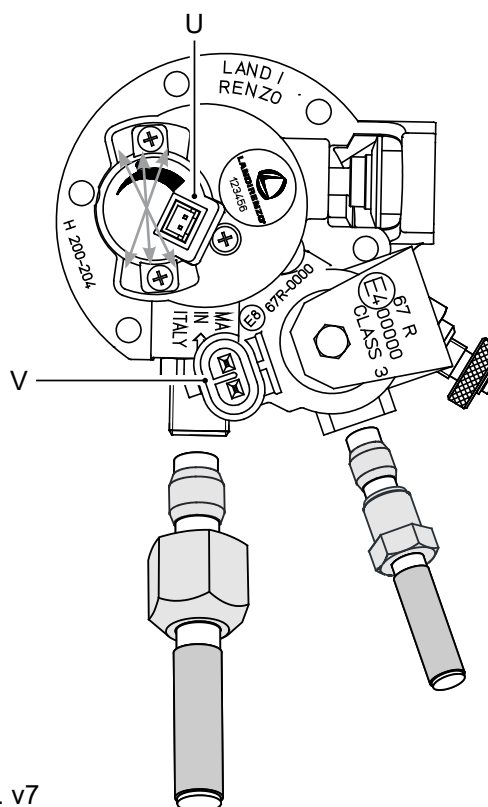

fig. v7

INSTALLING THE MULTIVALVE GUARD ON AN EXTERNAL TANK

- Fit strap "A" to the tank ring "C".
- Position the base of the guard "B" on the tank ring "C".
- Fit the multivalve "D".
- Tighten up the strap "A".
- Fit the high pressure pipes to the multivalve and connect the wiring for the fuel indicator and solenoid.
- Clip the cover "E" to the base "B".

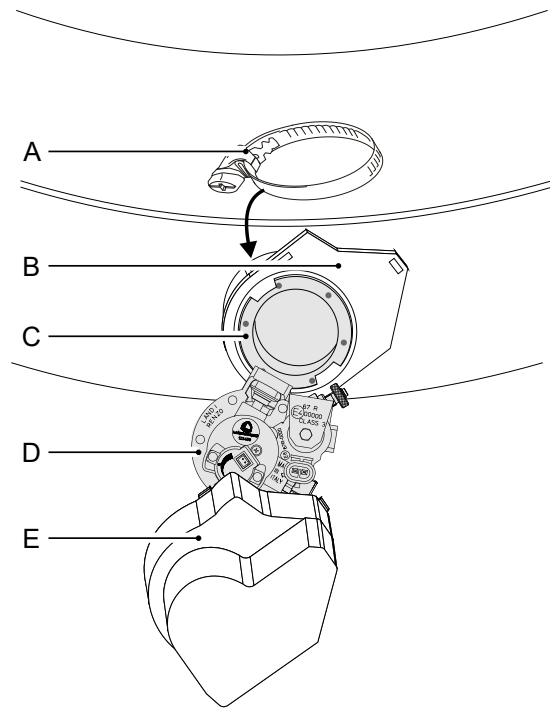

fig. p1

INSTALLING THE AIRTIGHT CHAMBER ON A CYLINDRICAL TANK

- Position the O-Ring "G" between the tank ring "F" and the base of the airtight chamber "H".
- Fit the multivalve "I".
- Fit the high pressure pipes to the multivalve and connect the wiring for the fuel indicator and solenoid.
- Clip on the cover "L".

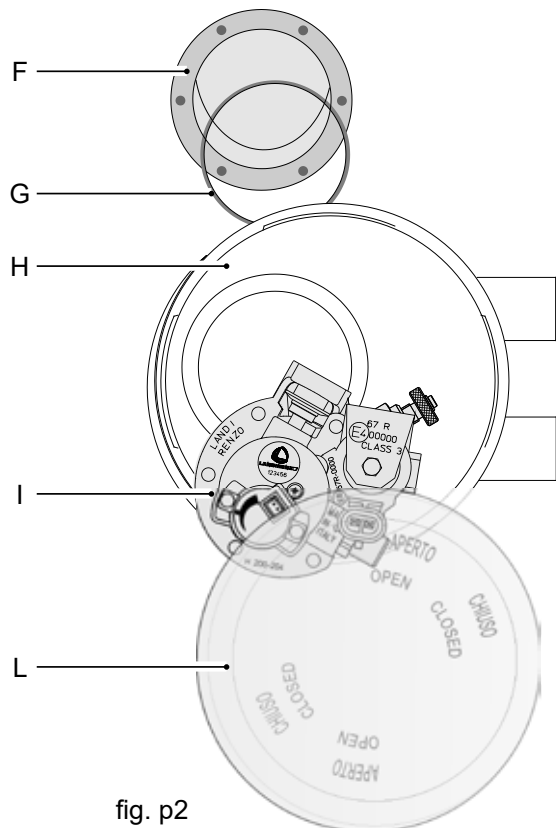

fig. p2

The inlet/outlet high pressure pipes and the wiring should be covered with flexible sheaths. Position the flexible sheaths on the joints of the chamber and fasten them in place with suitable clips (fig. p3). The same applies to the grommet that is to be fitted to the bodywork (fig. p4).

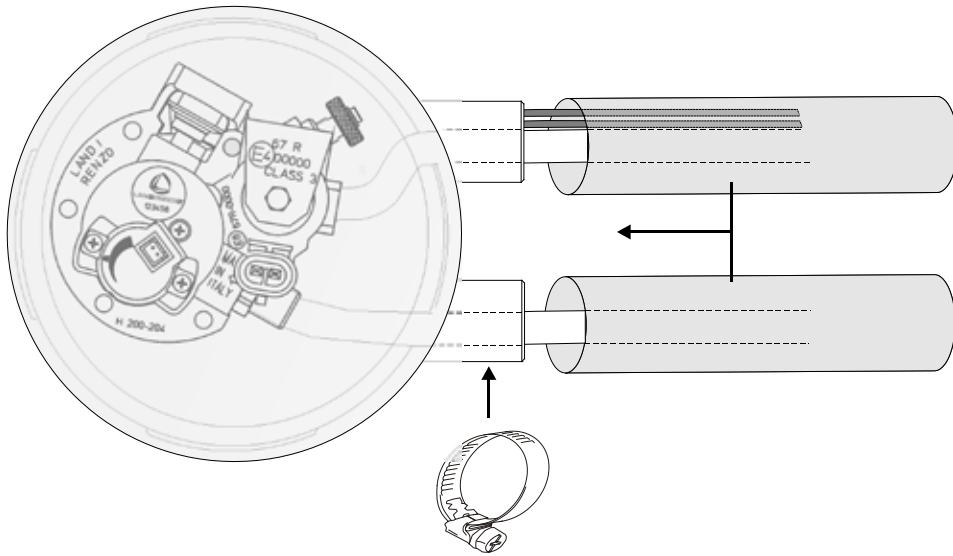

fig. p3

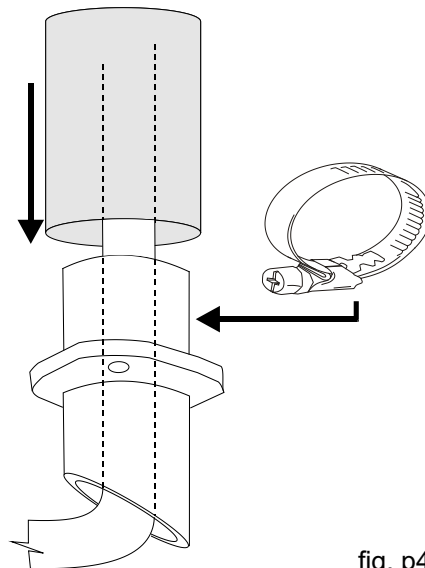

fig. p4

INSTALLING AIR VENTS INSIDE TRUNK COMPARTMENT

These breathers are to be fitted to the bodywork at the lowest point of the luggage compartment. The breathers are to be positioned so that the angled end of one faces the front of the vehicle and the other faces the rear. The aim is to minimise the forced passage of air ion the compartment.

NOTE

The installation of breathers in the luggage compartment is not obligatory and reference should be made to the legislation in force in the country where the vehicle is registered.

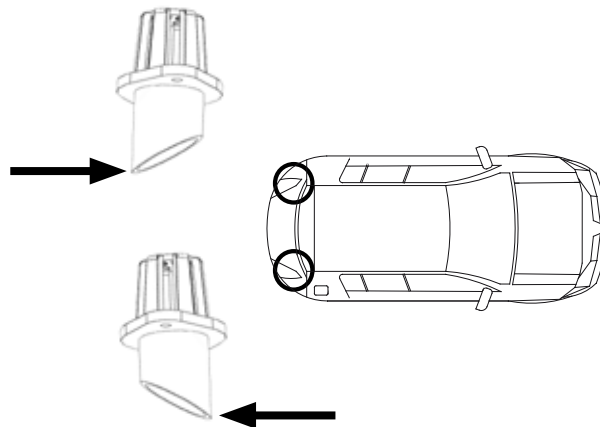
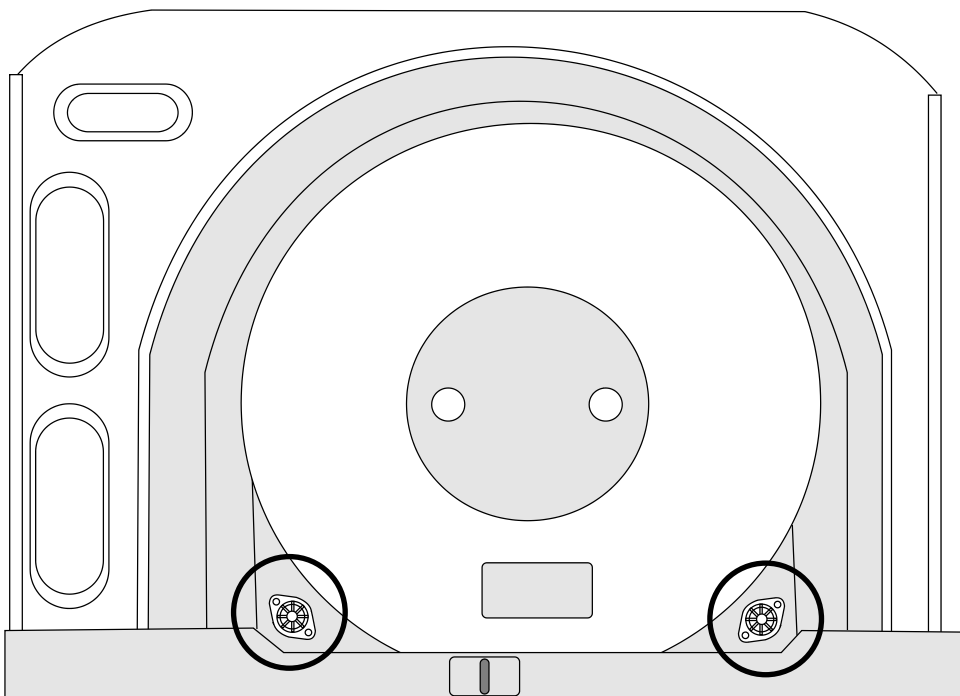

HIGH PRESSURE PIPES

PREPARING THE HIGH PRESSURE PIPES

Prepare the high pressure pipes using the cutter.

Remove any shavings remaining from cutting from the inner edge of the pipe.

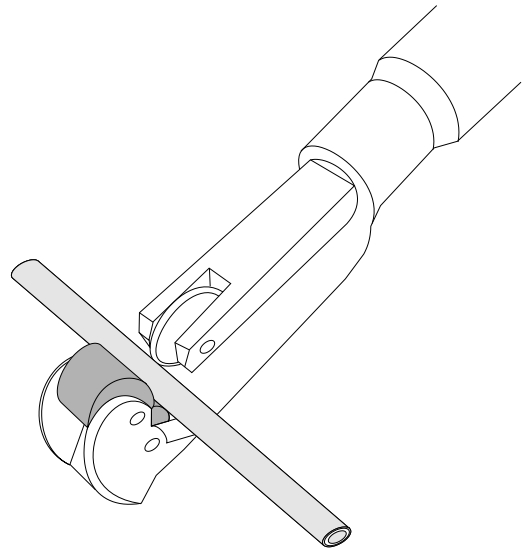
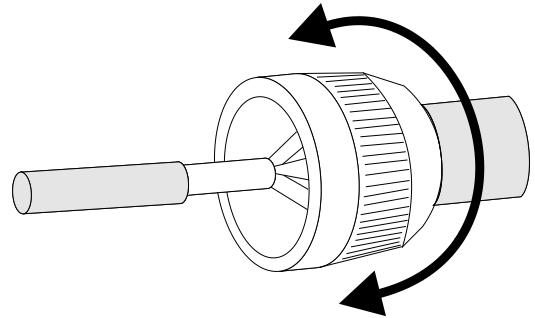

fig. I1



Cut the sheath covering the pipe at least 50 mm from the end of the pipe but do not leave the sheath too long.

ATTENTION

Take care not to bend with pipe when cutting the sheath. Shorten the pipe if necessary.

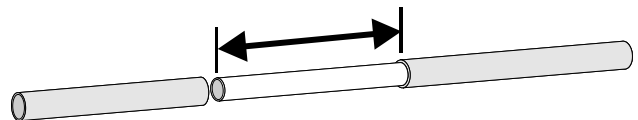
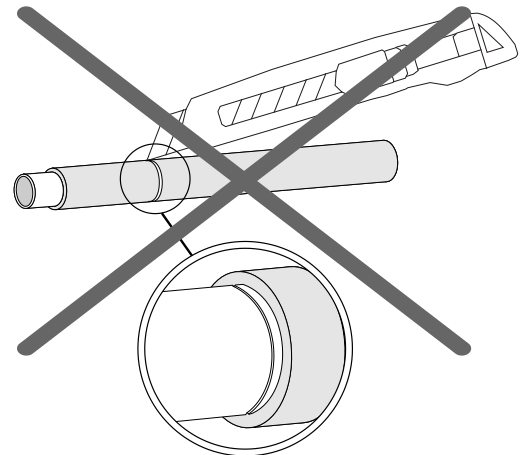

fig. I2



Fit the special joint "A" and compression ring "B" to the pipe. Put the prepared pipe in the bushing for the compression ring (fig.13).

While keeping the pipe under pressure, manually tighten the joint then use a spanner to tighten it up a few more turns (2/3). If available, use a torque wrench to tighten up to about 4 - 5 Nm (fig.14).

ATTENTION

The sole aim of this is to keep the compression ring in position while other joints are being made. For correct installation, the compression ring should be firmly in position no less than 2-3 mm from the start of the pipe. If the distance is less, shorten the pipe and repeat the operation (fig.15).

Shape the pipe manually taking care to avoid kinks and tight bends (fig.16).

Do not route high pressure pipes near the vehicle jacking points and position them at the legally required distance from the exhaust system. The legally required distance can be lessened if high pressure pipes are protected. It is best not to fasten high pressure pipes and wiring to brake lines.

The high pressure pipe and wiring going to the multivalve usually follow the same course. They are normally held in place with plastic clips (fig.18) or special supports (fig.17).

The high pressure pipe must always be fastened at regular intervals to original vehicle fittings (fig. 19) or additional supports (fig. 18).

The minimum distance between two fixing points is given in the specific standards.

Avoid contact between gas, water and brake lines and, if possible, also avoid clipping additional supports to brake lines.

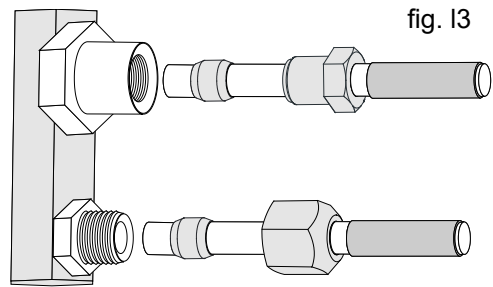

fig. 13

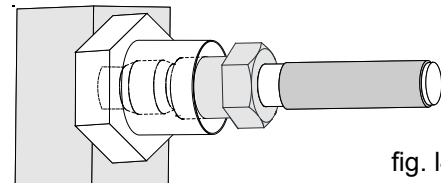

fig. 14

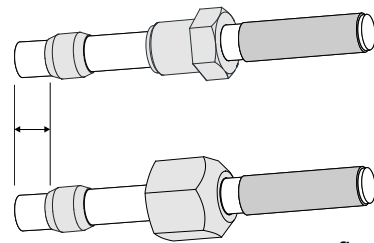

fig. 15

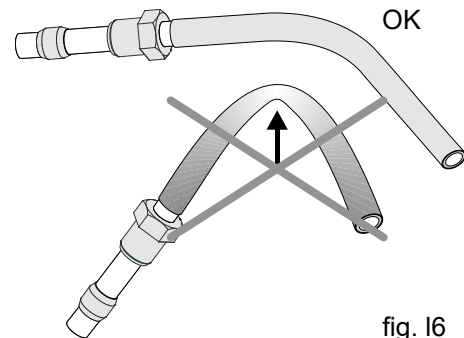

fig. 16

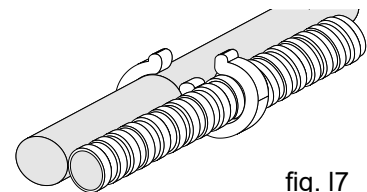

fig. 17

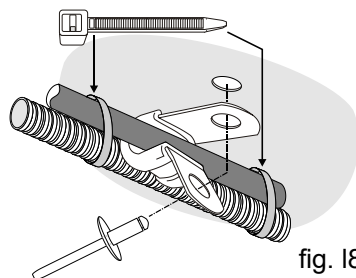

fig. 18

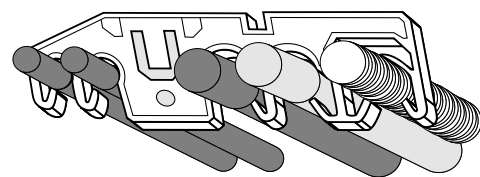

fig. 19

INSTALLATION OF THE REFUELLING VALVE

REFUELLING VALVE FOR GASOLINE COMPARTMENT

By using special accessories (see example in fig. g3), gas filler valves can be fitted to the hatch under the normal petrol filler flap (fig. g1). Always place the rubber gasket between the filler valve and the support bracket.

Drill a hole in the rear wall of the space under the flap to allow the filler valve and high pressure pipe to pass through.

If the "hatch" is made of thin plastic, we recommend the use of additional reinforcement for the valve bracket.

If there is sufficient room in the hatch for the valve to be fitted to the rear wall, the gas valve for the specific country of use (fig. g5 shows the "Italia" version) or the standard filler valve (fig. g2), can be fitted.

Use the gasket as a template to drill the Ø22 mm central hole. The holes for the retaining bolts depend on the type of bolts to be used.

Before fitting the valve, protect the bodywork with an anti-rust product.

If the "hatch" is made of thin plastic, we recommend the use of additional reinforcement for the valve bracket (see example in fig g4).

Fasten the valve cap cord to an original bolt or to one of the valve retaining bolts.

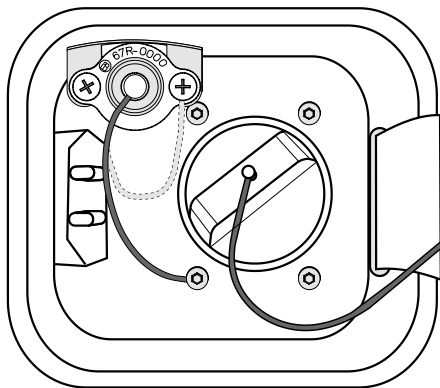

fig. g1

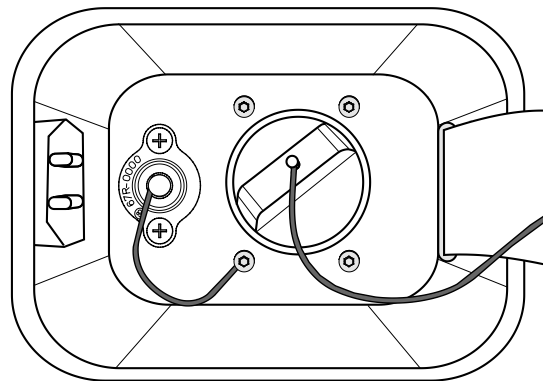

fig. g2



fig. g3



fig. g4

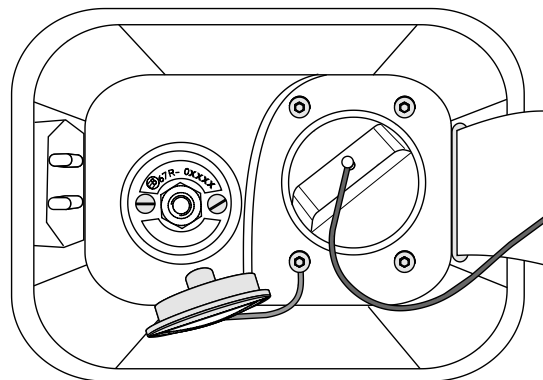

fig. g5

VERSION FOR BUMPER OR UNDER-BUMPER FITTING

First, identify a point on the bumper near the chassis that can be reached by the metal bracket that serves to support the valve and stop it from twisting.

Drill a hole in the bumper of the same size as the external support.

Place the filler valve in the external support then position both in the hole in the bumper.

Inside the bumper, assemble the inner bracket and the support bracket. Fasten the four components in place with suitable bolts. Lastly, fix the support bracket to the chassis.

To install the filler valve under the bumper, fix the support bracket to the chassis. Plastic internal/external brackets are not available.

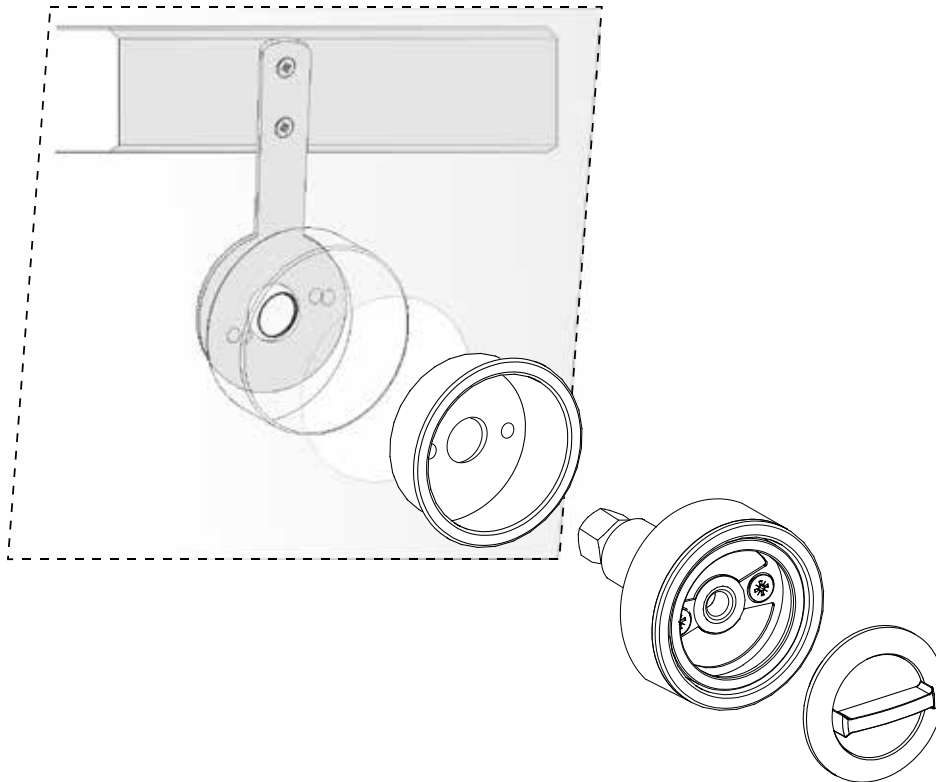

fig. g6

PNEUMATIC DIAGRAM - WITH LI10 PRESSURE REGULATOR

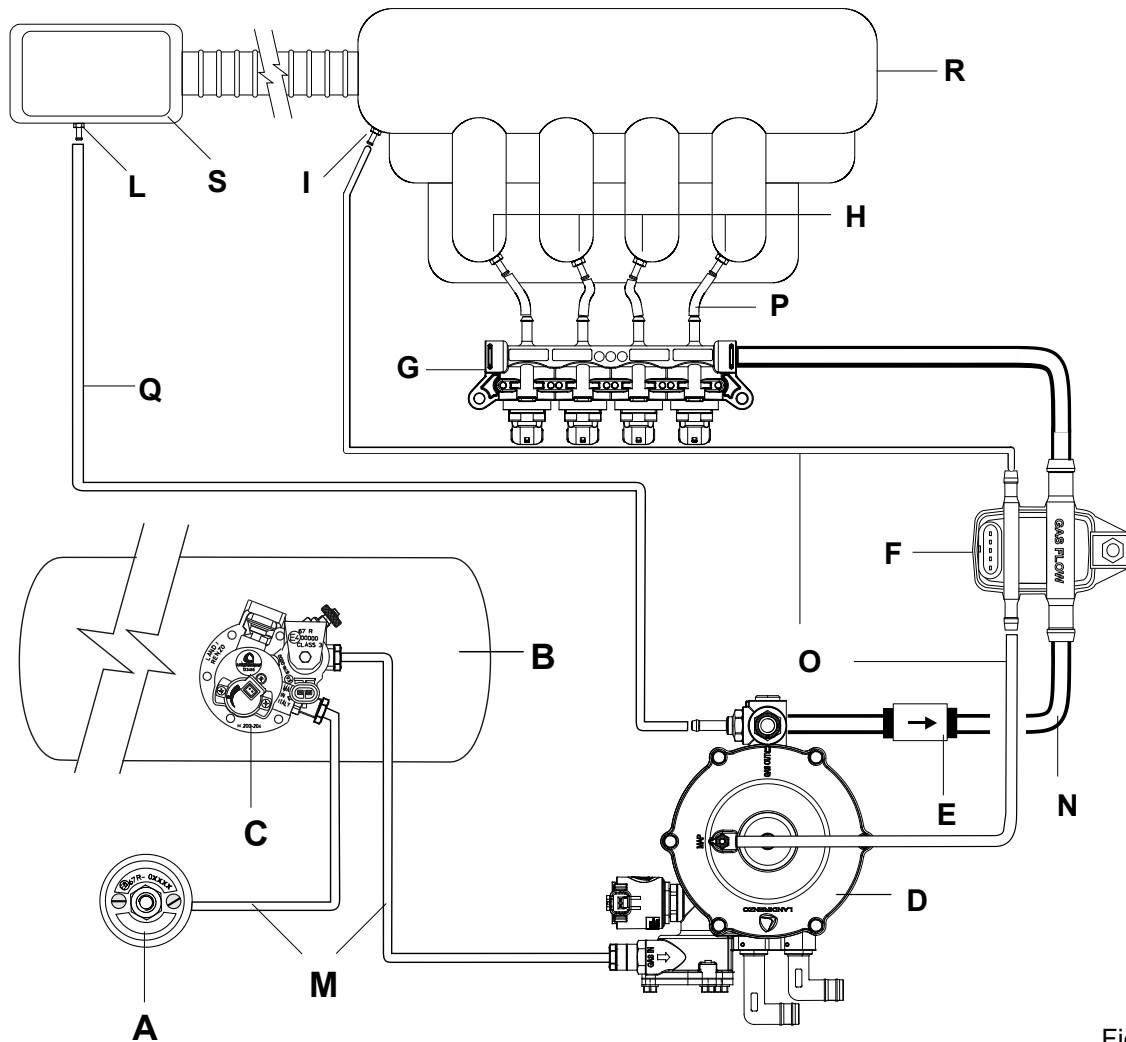

Fig. p1

Legend

- A Refuelling valve
- B Tank
- C Multivalve
- D Pressure regulator
- E Gas filter (optional)
- F Gas pressure/temperature sensor and MAP sensor
- G Gas injectors
- H Nozzles
- I Vacuum nozzle
- L Overpressure nozzle
- M High pressure gas pipes
- N Low pressure gas pipes
- O Tubi depressione
- P Nozzle pipes
- Q Overpressure hose
- R Engine intake manifold
- S Engine air filter

PNEUMATIC DIAGRAM - WITH LI02 PRESSURE REGULATOR

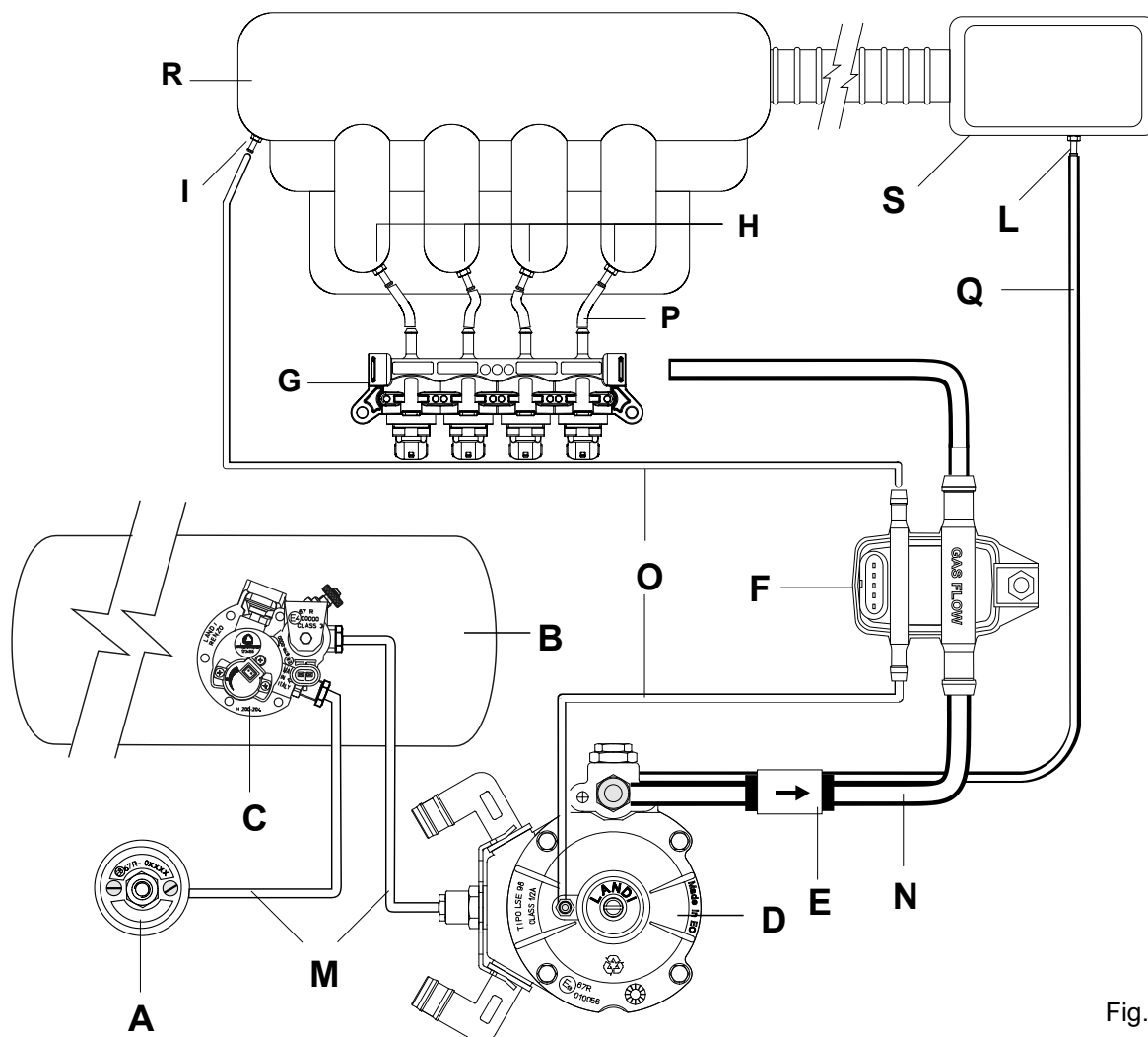

Fig. p2

Legend

- A Refuelling valve
- B Tank
- C Multivalve
- D Pressure regulator
- E Gas filter (optional)
- F Gas pressure/temperature sensor and MAP sensor
- G Gas injectors
- H Nozzles
- I Vacuum nozzle
- L Overpressure nozzle
- M High pressure gas pipes
- N Low pressure gas pipes
- O Tubi depressione
- P Nozzle pipes
- Q Overpressure hose
- R Engine intake manifold
- S Engine air filter

6 CYLINDER PNEUMATIC DIAGRAM - WITH LI10 PRESSURE REGULATOR

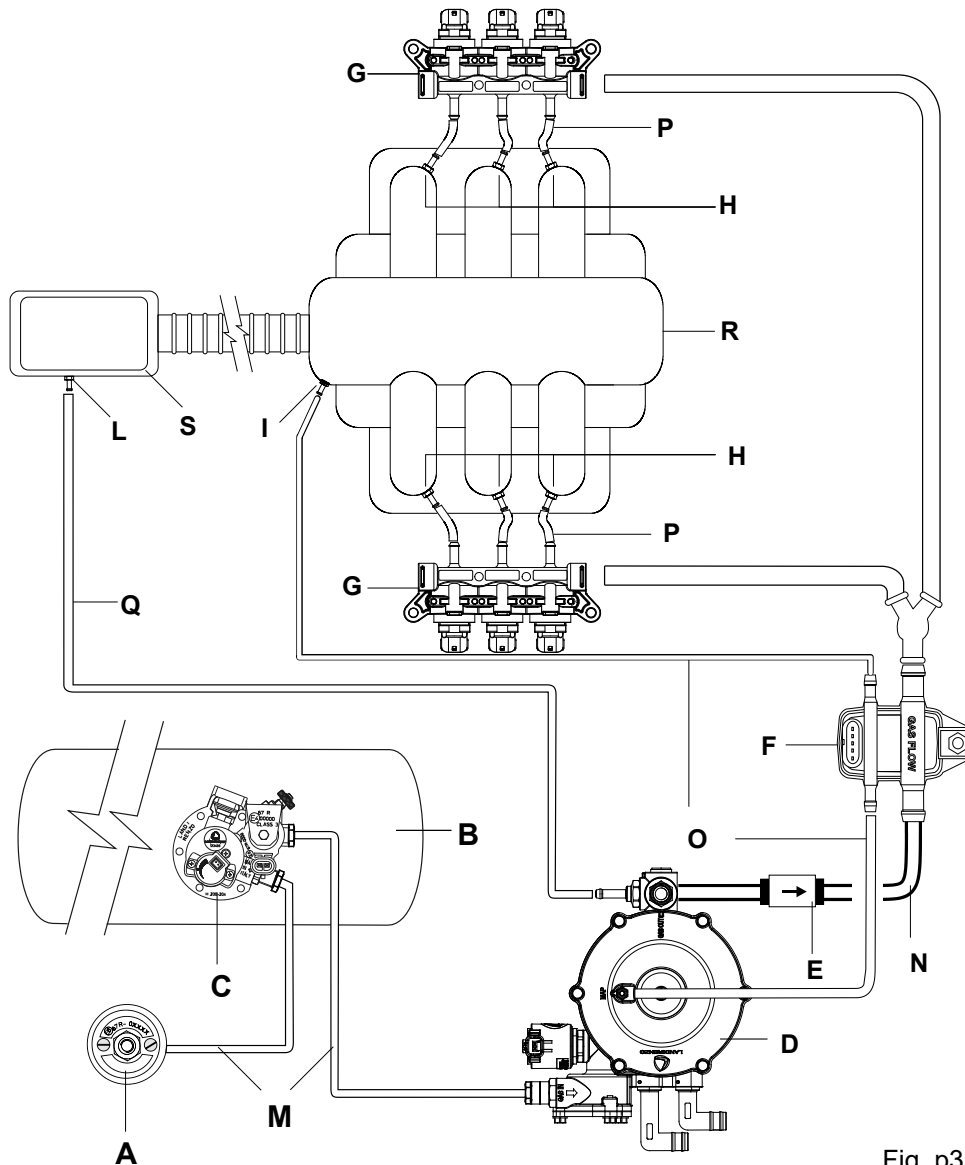

Fig. p3

Legend

- A Refuelling valve
- B Tank
- C Multivalve
- D Pressure regulator
- E Gas filter (optional)
- F Gas pressure/temperature sensor and MAP sensor
- G Gas injectors
- H Nozzles
- I Vacuum nozzle
- L Overpressure nozzle
- M High pressure gas pipes
- N Low pressure gas pipes
- O Tubi depressione
- P Nozzle pipes
- Q Overpressure hose
- R Engine intake manifold
- S Engine air filter

8 CYLINDER PNEUMATIC DIAGRAM - WITH LI10 PRESSURE REGULATOR

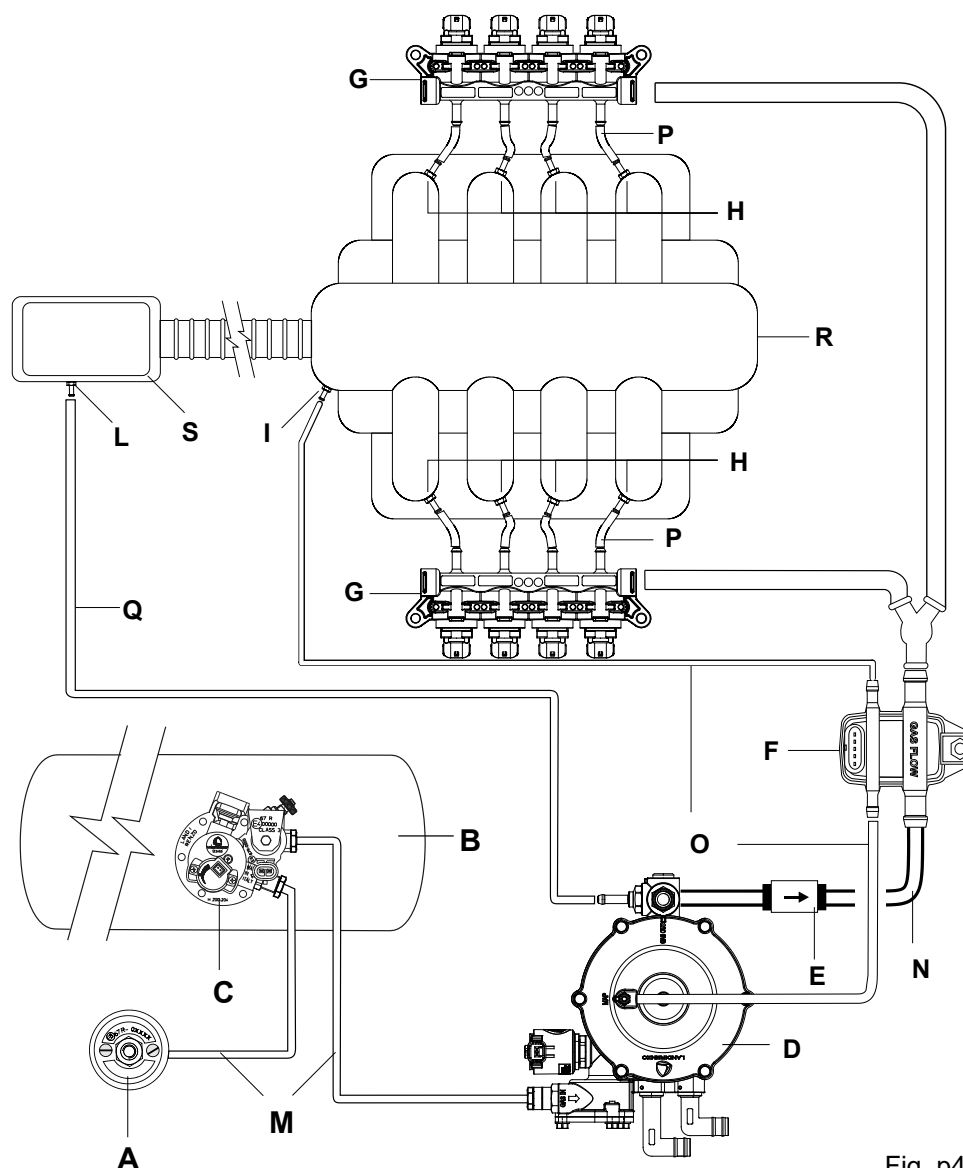

Fig. p4

Legend

- A Refuelling valve
- B Tank
- C Multivalve
- D Pressure regulator
- E Gas filter (optional)
- F Gas pressure/temperature sensor and MAP sensor
- G Gas injectors
- H Nozzles
- I Vacuum nozzle
- L Overpressure nozzle
- M High pressure gas pipes
- N Low pressure gas pipes
- O Tubi depressione
- P Nozzle pipes
- Q Overpressure hose
- R Engine intake manifold
- S Engine air filter

OMEGAS EVO WIRING DIAGRAM

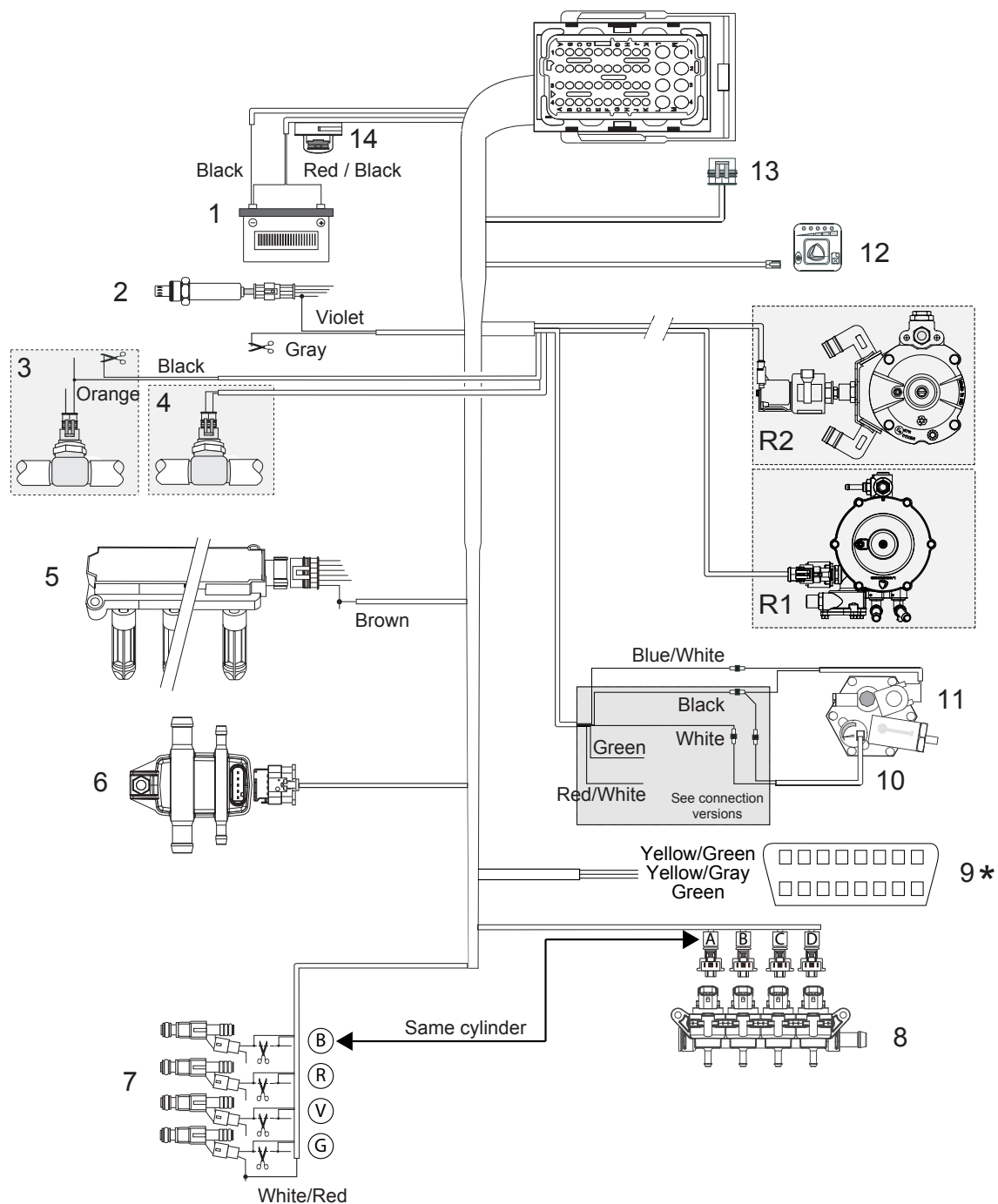

Fig. e1

Legend

- | | |
|---|-----------------------------|
| 1. Battery | 10. Fuel level indicator |
| 2. Lambda probe | 11. Multivalve |
| 3. Original engine temperature sensor | 12. Switch |
| 4. Optional temperature sensor | 13. Diagnosis / programming |
| 5. Ignition coil (instead of RMP signal) | 14. Fuse |
| 6. Gas pressure/temperature sensor and MAP sensor | R1 Pressure regulator LI10 |
| 7. Petrol injectors | R2 Pressure regulator LI02 |
| 8. Gas injectors | |
| 9. OBD interface (on Landirenzo omegas system) | |

OMEGAS EVO WIRING DIAGRAM 6 CYLINDER

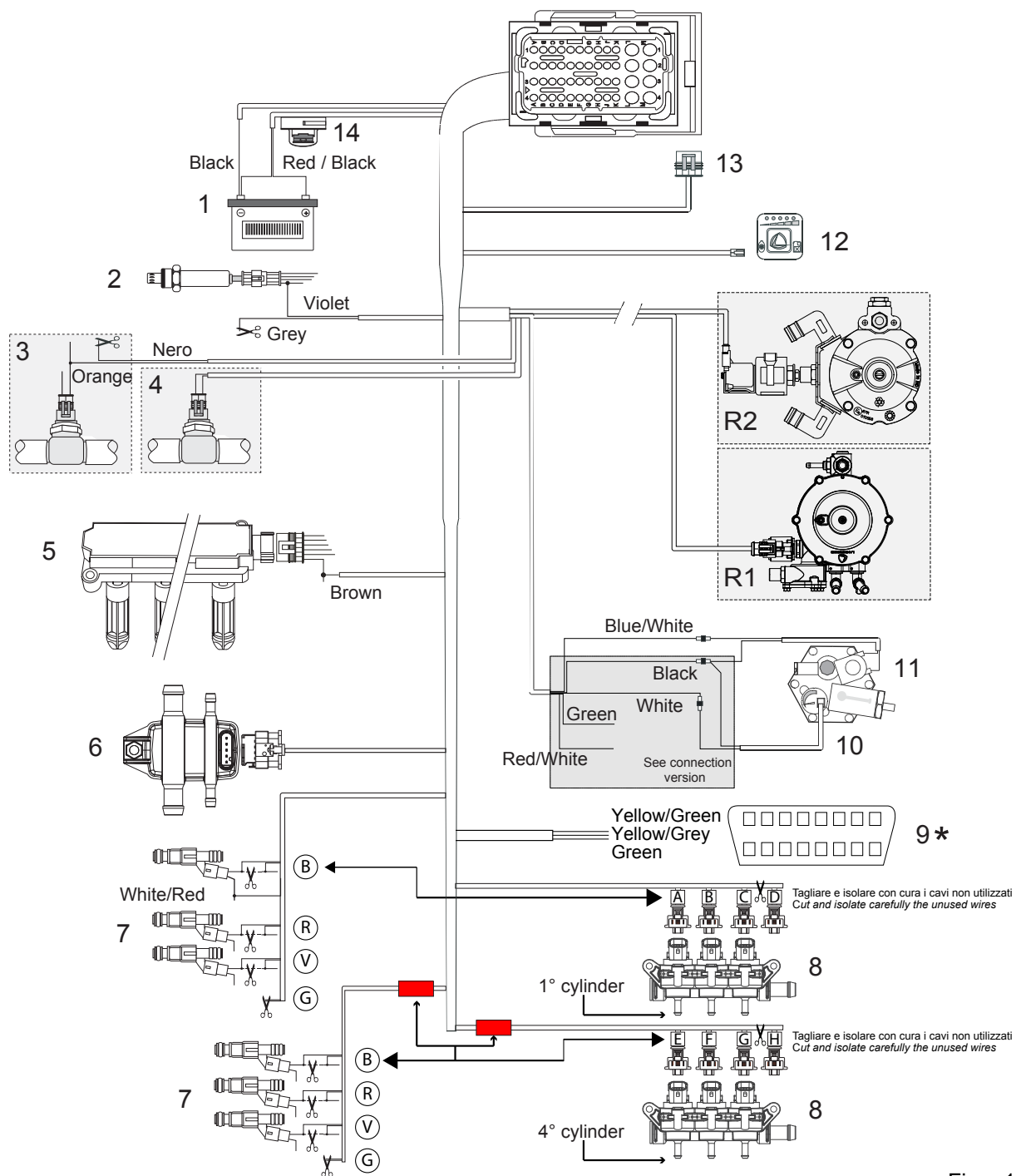

Fig. e1

- | | |
|---|-----------------------------|
| 1. Battery | 10. Fuel level indicator |
| 2. Lambda probe | 11. Multivalve |
| 3. Original engine temperature sensor | 12. Switch |
| 4. Optional temperature sensor | 13. Diagnosis / programming |
| 5. Ignition coil (instead of RMP signal) | 14. Fuse |
| 6. Gaspressure/temperaturesensorandMAPsensor | R1 Pressure regulator LI10 |
| 7. Petrol injectors | R2 Pressure regulator LI02 |
| 8. Gas injectors | |
| 9. OBD interface (on Landireenzo omegas system) | |

OMEGAS EVO WIRING DIAGRAM 8 CYLINDER

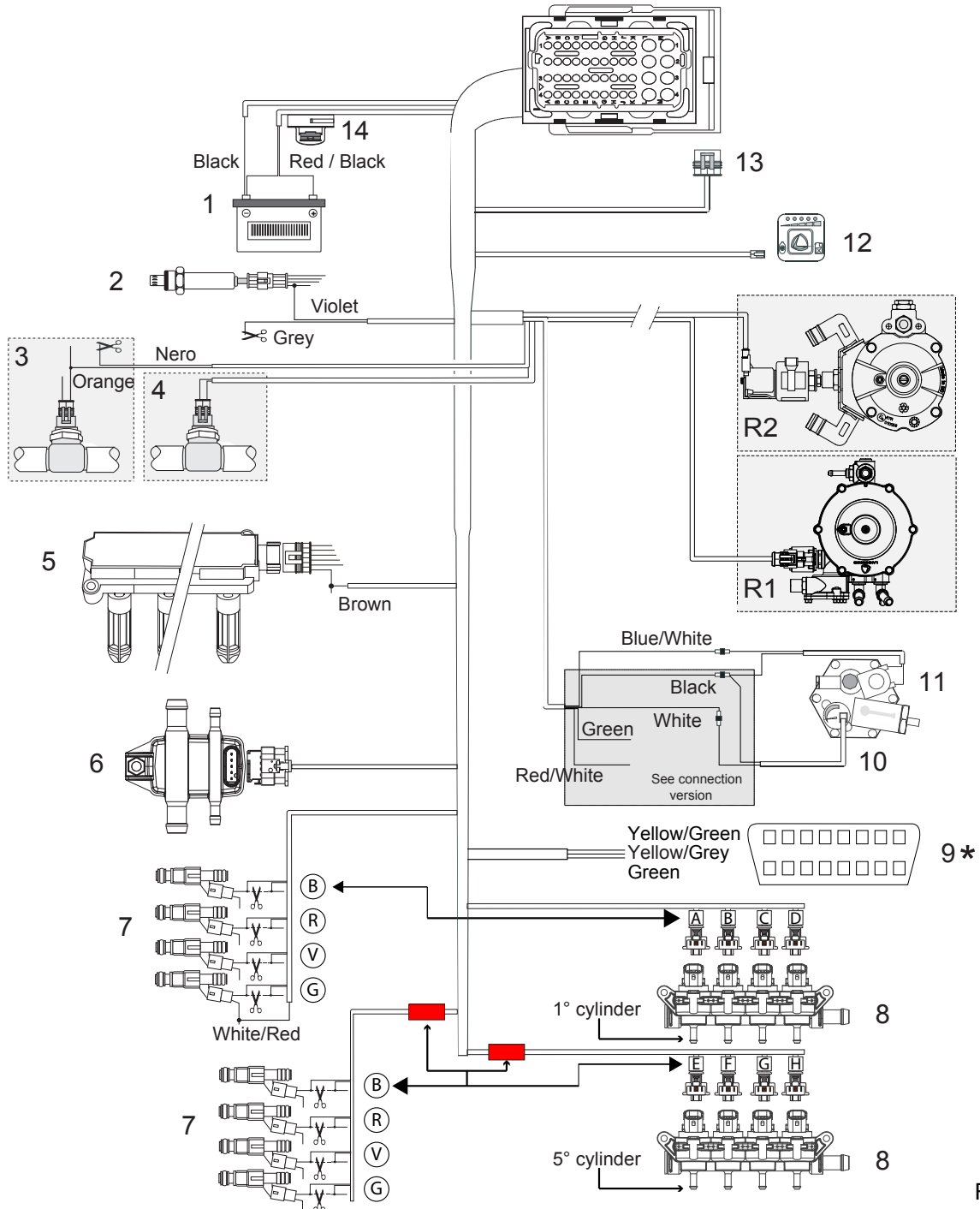
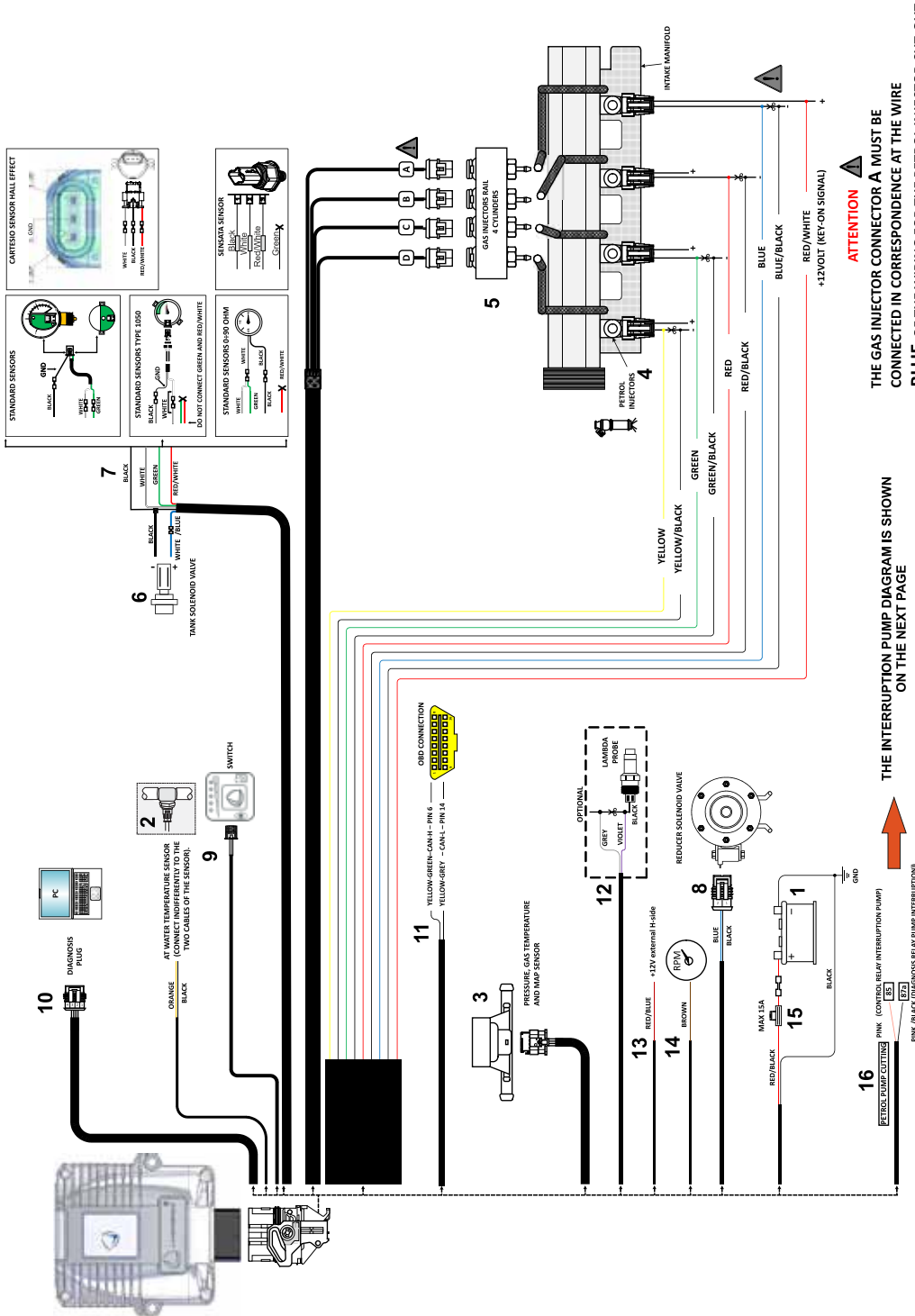

Fig. e1

- | | |
|--|---|
| <ol style="list-style-type: none"> 1. Battery 2. Lambda probe 3. Original engine temperature sensor 4. Optional temperature sensor 5. Ignition coil (instead of RMP signal) 6. Gas pressure/temperature sensor and MAP sensor 7. Petrol injectors 8. Gas injectors 9. OBD interface (on Landirenzo omegas system) | <ol style="list-style-type: none"> 10. Fuel level indicator 11. Multivalve 12. Switch 13. Diagnosis / programming 14. Fuse R1 Pressure regulator LI10 R2 Pressure regulator LI02 |
|--|---|

OMEGAS 4.0 WIRING DIAGRAM



PETROL PUMP CUTTING DIAGRAM (OPTIONAL)

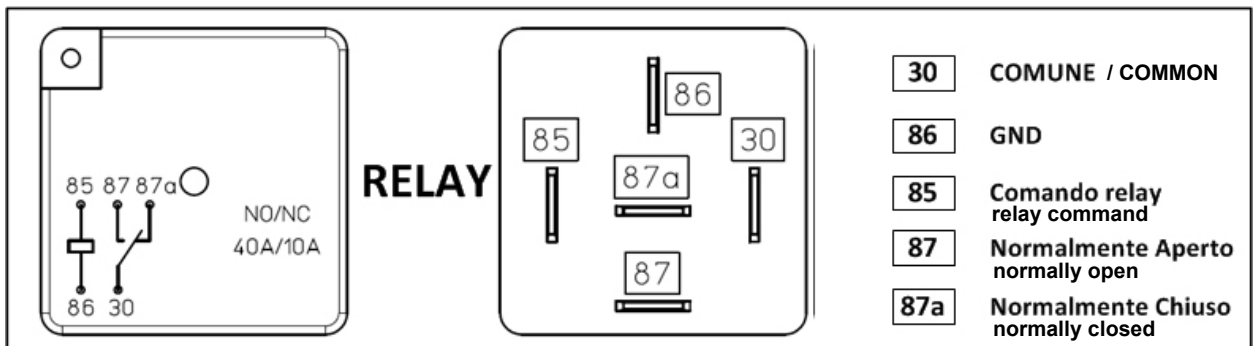
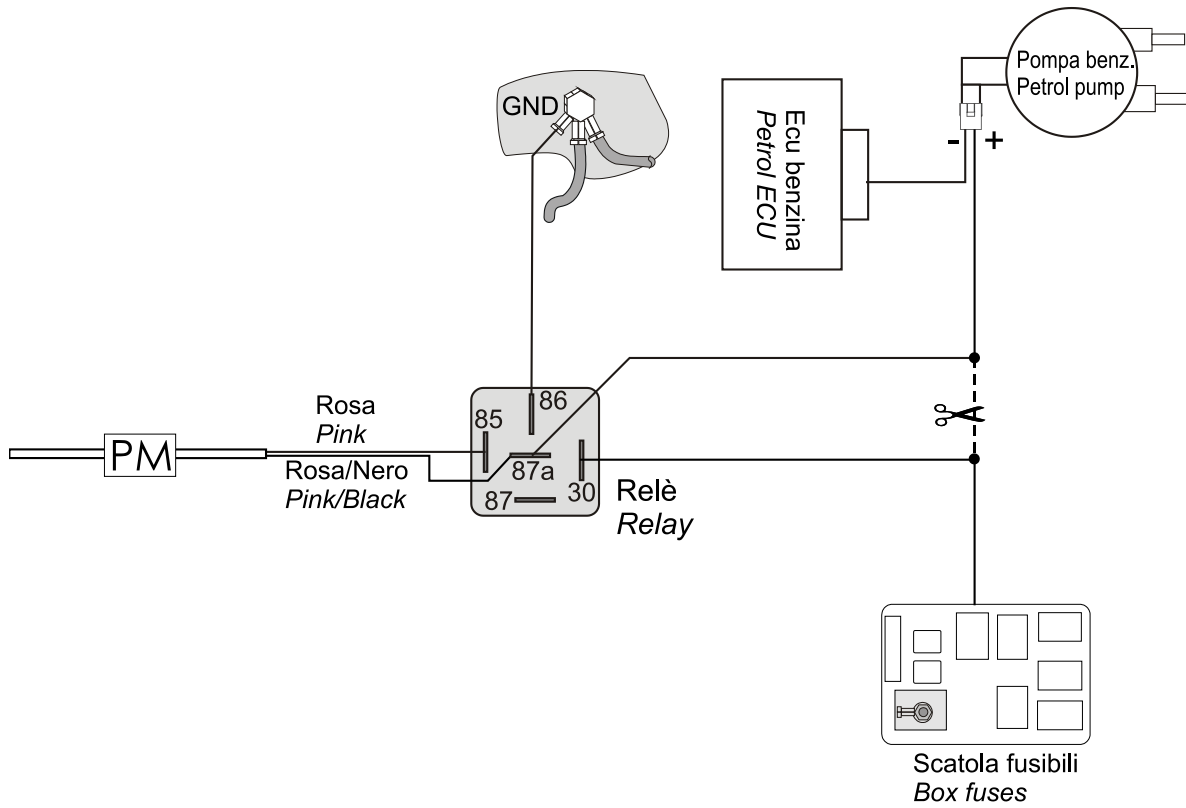

EVO-L WIRING DIAGRAM

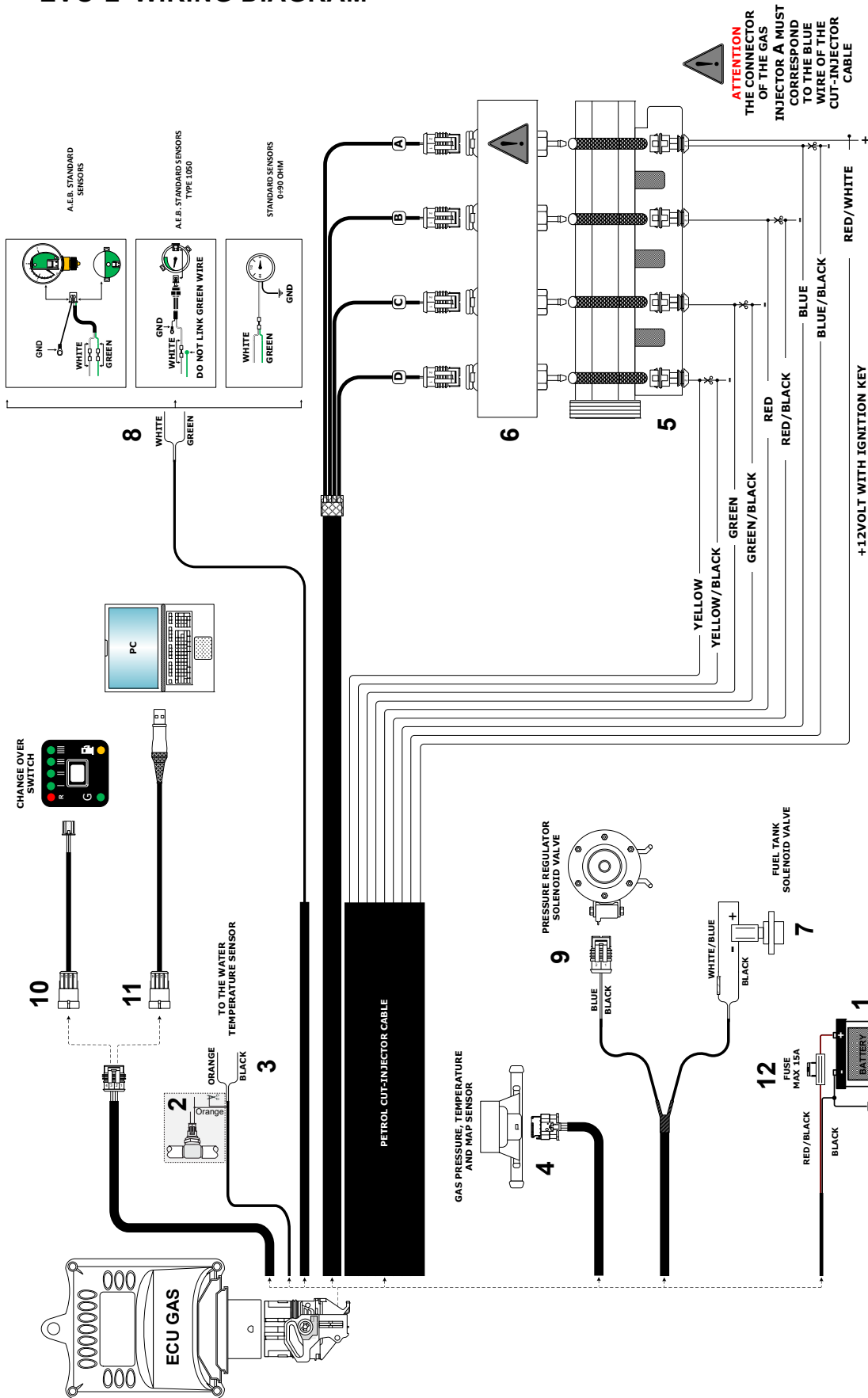

FUEL LEVEL SENSOR CONNECTIONS

LANDI RENZO / AEB 1050

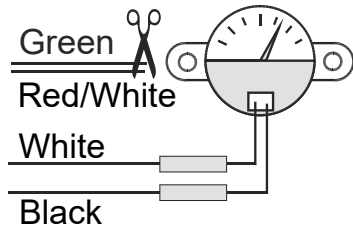

AEB STANDARD

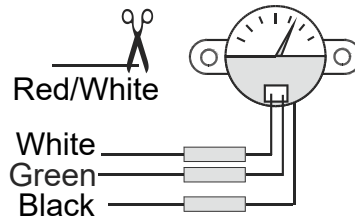

0-90 Om

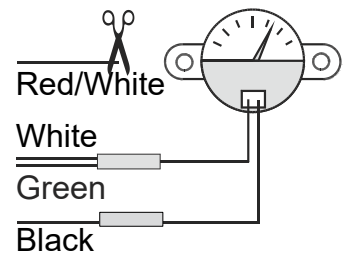

Connection variants OBD connection

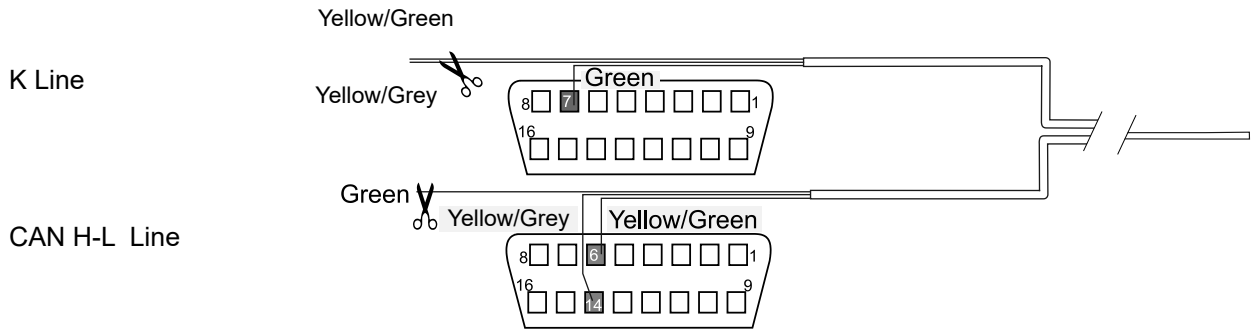

PETROL INJECTORS EXCLUSION

The wiring for the petrol injector cut-out and for the gas injector power supply are inter-connected. The sequence and pairing for the petrol injector cut-out is: "BLUE - "A", RED - "B", GREEN -"C", YELLOW-"D". The "BLUE" wire pairing must be connected to the petrol injector that pairs with the gas injector connected to the main wiring harness marked with "A" (see fig e2). The other wire pairings and connectors must be connected using the same sequence as above except for specific cases that are noted in the installation sheet.

Petrol injector cut-out		Gas injector connectors
Blue - Blue/Black	"B"	A
Red - Red/Black	"R"	B
Green - Green/Black	"V"	C
Yellow - Yellow/Black	"G"	D

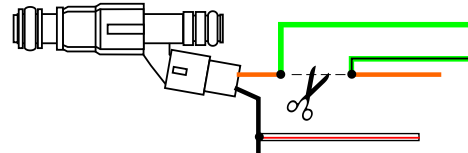

Connect each of the pairs by colour (e.g Green-Green/Black) to the "negative" injector wire. The "single-coloured" wire is to be connected to the cut end of the original wire going to the petrol injector. The "two-coloured" wire is to be connected to the cut end of the original wire going to the petrol injection ECU. The WHITE/RED wire is to be connected to the "ignition on" wire of one of the petrol injectors or another engine ancillary provided that it is used during starting. It need not necessarily be associated with the timing.

Engine cylinder number	Wiring without colored sheaths				Wiring with red sheath			
	Injector connector / Cut Injector wiring harness				Injector connector / Cut Injector wiring harness			
3	A / B	B / R	C / V	X / X				
4	A / B	B / R	C / V	D / G				
5	A / B	B / R	C / V	X / X	E / B	F / R	X / X	X / X
6	A / B	B / R	C / V	X / X	E / B	F / R	G / V	X / X
8	A / B	B / R	C / V	D / G	E / B	F / R	G / V	H / G

For installations on 3-5-6 cylinder engines, the connectors or wires not used must be insulated with care.

Connections for 3 cylinder system
Connectors "D" and YELLOW-YELLOW/BLACK wires, must not be connected.

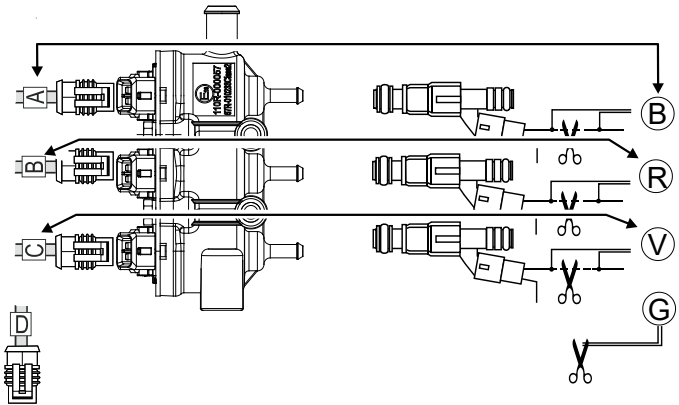

Connections for 4 cylinder system

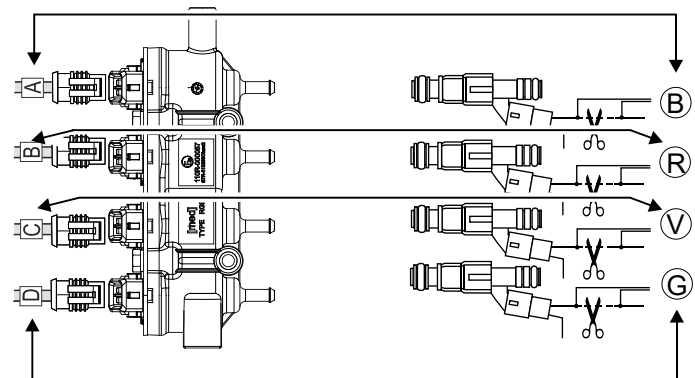

Connections for 5 cylinder system

Connector "D" and YELLOW-YELLOW/BLACK wires of the wiring without sheath, must not be connected.

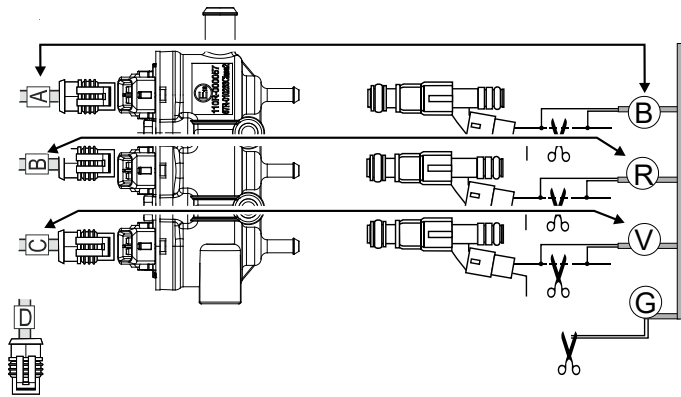

Connectors "G" and "H", wires GREEN- GREEN/ BLACK and YELLOW-YELLOW/BLACK, of the wiring without Red sheath, must not be connected.

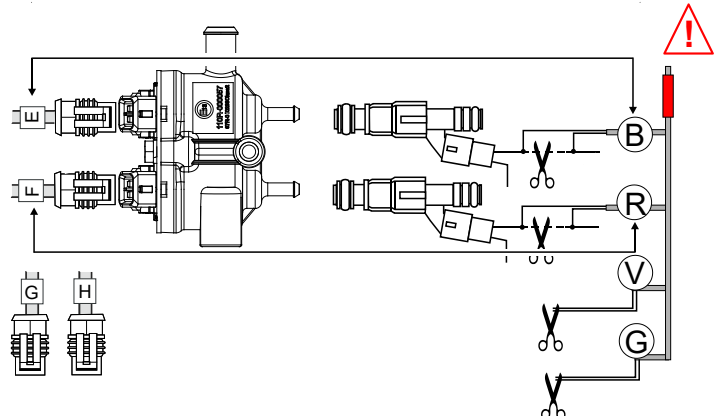

Connections for 6 cylinder system.

Connectors "D" and YELLOW-YELLOW/BLACK wires of the wiring without colored sheath, must not be connected.

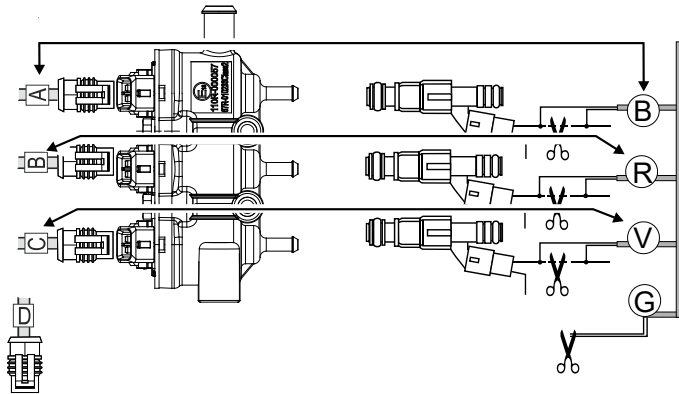

Connectors "H" and YELLOW-YELLOW/BLACK wires of the wiring with "RED" sheath, must not be connected.

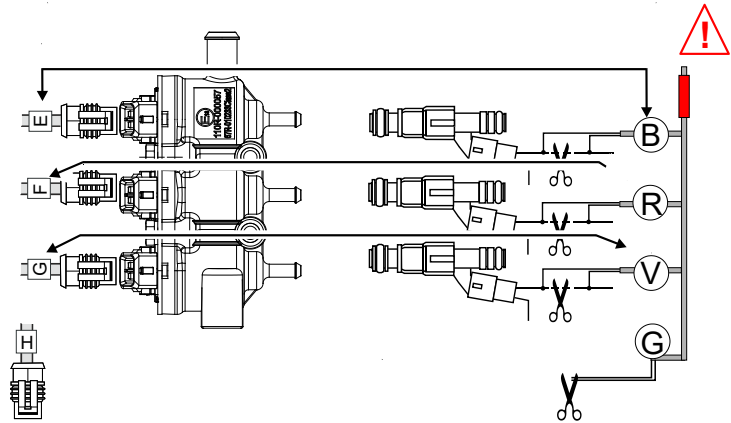

Connections for 8 cylinder system.

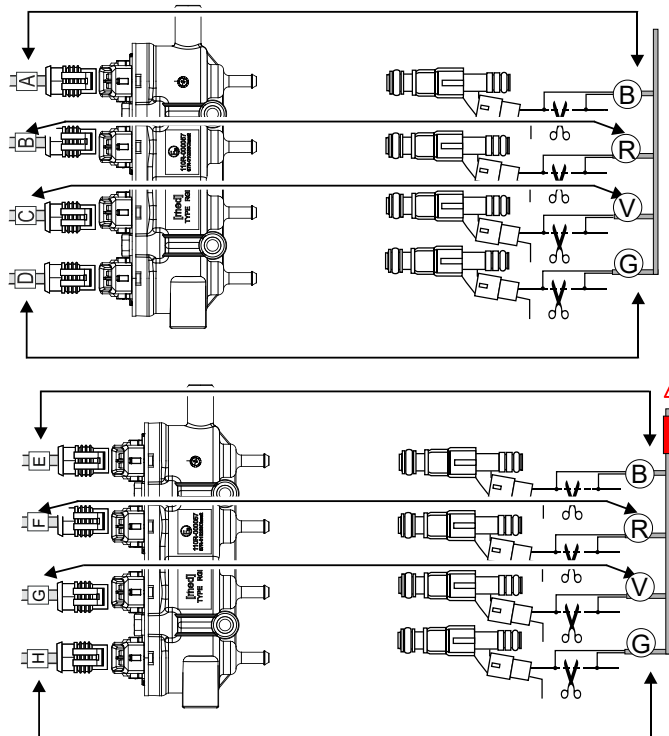

PROGRAMMING THE ECU

Model-specific kits come with a pre-programmed ECU.

Generic kits come with a “neutral” ECU.

An interface cable is needed to connect to the PC for programming “neutral” ECUs, for calibration work and for carrying out periodical checks. The PC must have had a specific programme installed, can be downloaded in the reserved area as shown below:

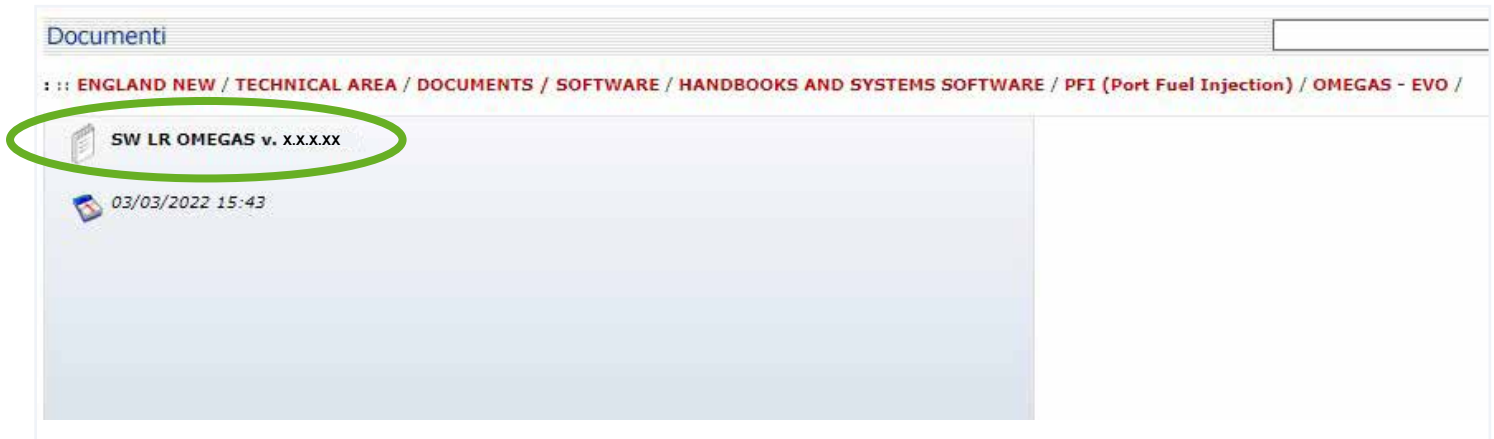

INTERFACE CABLE CONNECTION

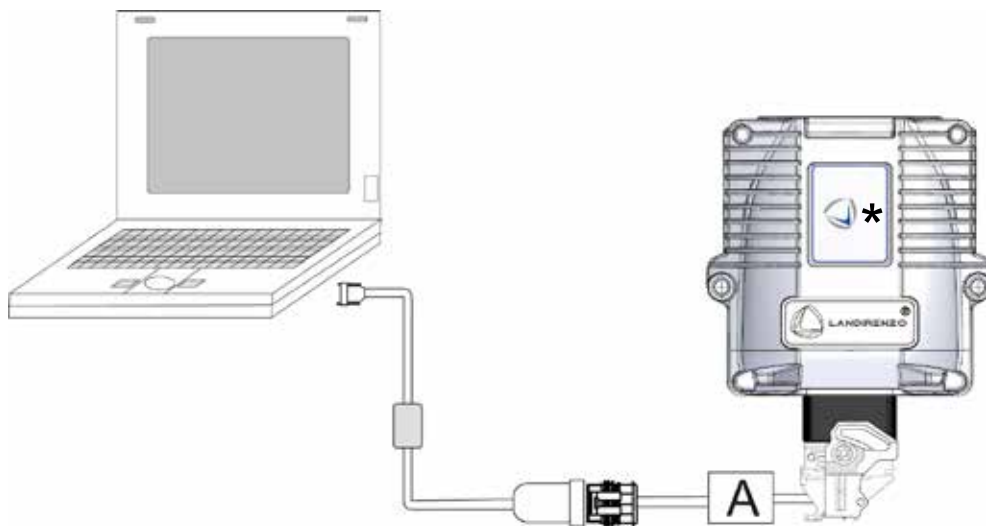

* OMEGAS and EVO

LANDIRENZO



LANDIRENZO®

via Nobel, 2 | 42025 Corte Tegge | Cavriago (RE) | Italia
Tel. +39 0522 9433 | Fax +39 0522 944044 | www.landi.it | e-mail: info@landi.it